

**OPERATOR'S, AVIATION UNIT, AND
AVIATION INTERMEDIATE MAINTENANCE
AND
ILLUSTRATED PARTS BREAKDOWN**

**TEST SET, LINE
ADVANCED FLIGHT CONTROL SYSTEM
145G0009-1**

NSN 4920-01-121-0603

HEADQUARTERS, DEPARTMENT OF THE ARMY

16 NOVEMBER 1983

CHANGE

HEADQUARTERS

DEPARTMENT OF THE ARMY

NO. 2

WASHINGTON, D.C., 28 May 1993

OPERATOR'S AVIATION UNIT, AND
 AVIATION INTERMEDIATE MAINTENANCE
 AND
 ILLUSTRATED PARTS BREAKDOWN

TEST SET, LINE, ADVANCED FLIGHT
 CONTROL SYSTEM (AFCS 145G0009-1)
 NSN 4920-01-121-0603

DISTRIBUTION STATEMENT A: Approved for public release; distribution is unlimited.

TM 55-4920-429-13, 16 November 1983 is changed as follows:

1. Remove and insert pages as indicated below. New or changed text material is indicated by a vertical bar in the margin. An illustration change is indicated by a miniature pointing hand.

Remove pages

i and ii
 1-1 and 1-2
 4-13 and 4-14
 4-25 and 4-26
 A-1/(A-2 blank)
 B-1 and B-2

Insert pages

i and ii
 1-1 and 1-2
 4-13 and 4-14
 4-25 and 4-26
 A-1/(A-2 blank)
 B-1 and B-2

2. Retain this sheet in front of manual for reference purposes.

By Order of the Secretary of the Army:

Official:

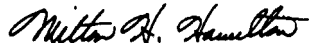

MILTON H. HAMILTON

*Administrative Assistant to the
Secretary of the Army*

04312

GORDON R. SULLIVAN
*General, United States Army
Chief of Staff*

DISTRIBUTION:

To be distributed in accordance with DA Form 12-31-E, block no. 1216, requirements for TM 55-4920-429-13.

CHANGE }
 NO. 1 }

HEADQUARTERS
 DEPARTMENT OF THE ARMY
 WASHINGTON, D.C., 30 January 1987

Operator's Aviation Unit, and
 Aviation Intermediate Maintenance
 and
 Illustrated Parts Breakdown

Test Set, Line, Advanced Flight
 Control System (AFCS 145G0009-1)
 NSN 4920-01-121-0603

TM 55-4920-429-13, 16 November 1983 is changed as follows:

1. Remove and insert pages as indicated below. New or changed text material is indicated by a vertical bar in the margin. An illustration change is indicated by a miniature pointing hand.

Remove pages

i and ii
 1-1 and 1-2
 B-1 through B-4
 A-1/A-2
 5-1 through 5-4
 5-11 through 5-14
 5-17 and 5-18
 FO-7

Insert pages

i and ii
 1-1 and 1-2
 B-1 through B-4
 A-1/A-2
 5-1 through 5-4
 5-11 through 5-14
 5-17 and 5-18
 FO-7

2. Retain this sheet in front of manual for reference purposes.

By Order of the Secretary of the Army:

JOHN A. WICKHAM, JR.
General, United States Army
Chief of Staff

Official:

R. L. DILWORTH
Brigadier General, United States Army
The Adjutant General

DISTRIBUTION:

To be distributed in accordance with DA Form 12-31, AVUM and AVIM Maintenance requirements for CH-47D Helicopter, Cargo Transport.

SAFETY SUMMARY

The following are general safety precautions that are not related to any specific procedures and therefore do not appear elsewhere in this publication. These are recommended precautions that personnel must understand and apply during many phases of operation and maintenance.

KEEP AWAY FROM LIVE CIRCUITS.

Maintenance personnel must at all times observe all safety regulations. Do not replace components or make adjustments inside the equipment with the high voltage supply connected. To avoid casualties, always remove power from a circuit before touching it.

DO NOT SERVICE OR ADJUST ALONE.

Under no circumstances should any person reach into the test set for the purpose of servicing or adjusting the equipment except in the presence of someone who is capable of rendering aid.

Personnel working with or near high voltage should be familiar with modern methods of resuscitation (CPR) (Ref FM21-1). Such information may be obtained from the Bureau of Medicine and Surgery.

The following warnings appear in the text in this volume, and are repeated here for emphasis.

WARNING

The test set weighs approximately 68 pounds. Be careful when lifting the test set to prevent personal injury.

WARNING

HIGH voltage is used in this equipment. Death on contact or severe injury can result if personnel fail to observe safety precautions.

Learn the equipment areas containing high voltage. Before working inside this equipment, turn off the equipment and disconnect all power at the source. Be careful not to touch high voltage connections when performing maintenance on this equipment.

WARNING

- Naphtha and dry cleaning solvent are combustible and toxic. Keep away from open flame.
- Isopropyl alcohol and trichloroethane are toxic.
- Use these chemicals with adequate ventilation. They can irritate skin. In case of contact, immediately flush skin or eyes with water for 15 minutes. Get medical attention at once.

OPERATOR'S, AVIATION UNIT, AND
AVIATION INTERMEDIATE MAINTENANCE
AND
ILLUSTRATED PARTS BREAKDOWN

TEST SET, LINE, ADVANCED FLIGHT
CONTROL SYSTEM (AFCS 145 G0009-1)
NSN 4920-01-121-0603

REPORTING OF ERRORS

You can help improve this manual. If you find any mistake or if you know of a way to improve the procedures, please let us know. Mail your letter, DA Form 2028 (Recommended Changes to Publications) or DA Form 2028-2 located in the back of this manual direct to: Commander, U.S. Army Aviation and Troop Command, ATTN: AMSAT-I-MP, 4300 Goodfellow Blvd., St. Louis, MO 63120-1798. A reply will be furnished to you.

DISTRIBUTION STATEMENT A: Approved for public release; distribution is unlimited,
TABLE OF CONTENTS

CHAPTER 1	INTRODUCTION	
Section I	General Information	1-1
Section II	Equipment Description and Data	1-4
Section III	Technical Principles of Operation	1-5
CHAPTER 2	OPERATING INSTRUCTIONS	
SECTION I	Preparation for Use	2-1
Section II	Operation	2-3
Section III	Preventive Maintenance Checks and Services	2-15
CHAPTER 3	AVUM MAINTENANCE	
Section I	AVUM Maintenance Instructions	3-1
Section II	Preventive Maintenance Checks and Services	3-6
CHAPTER 4	AVIM MAINTENANCE	
Section I	Troubleshooting	4-1
Section II	Maintenance	4-3
CHAPTER 5	ILLUSTRATED PARTS BREAKDOWN	
Section I	Introduction	5-1
Section II	Repair Parts List	5-9
APPENDIX A	REFERENCE	A-1
APPENDIX B	MAINTENANCE ALLOCATION CHART	B-1
Section II	Introduction	B-1
Section II	Maintenance Allocation Chart	B-4
Section III	Tool and Test Equipment Requirements	B-8
ALPHABETIC INDEX		Index 1

LIST OF FOLDOUT

Foldout	Title	Page
FO-1	AFCS Line Test Set Block Diagram	FO-1
FO-2	Discrete Signal Monitor Circuits Simplified Schematic Diagram	FO-2
FO-3	Discrete Signal Monitor Detailed Schematic Diagram	FO-3
FO-5	Extensible Link Servo-Control Simplified Schematic Diagram	FO-5
FO-6	Extensible Link Servo Loop Digital Schematic Diagram	FO-6
FO-7	Digital Multimeter Schematic Diagram	FO-7
FO-8	AFCS Line Test Set Schematic Diagram	FO-8.1
FO-22	Wiring Diagram	FO-22.1

LIST OF ILLUSTRATIONS

Figure	Title	Page
1-1	AFCS Line Test Set	1-2
1-2	Demodulation Circuit Waveforms	1-11
1-3	Comparison of Command, Feedback, and Demand Voltages	1-12
1-4	Digital Multimeter Display Schematic Diagram	1-15
2-1	Typical Packaging of Test Set	2-2
2-2	AFCS Line Test Set Controls and Indicators	2-3
2-3	Test Set Connection to Helicopter	2-12
3-1	Cable W1 Wiring Diagram	3-3
3-2	Cable W2 wiring Diagram	3-4
3-3	Cable W3 Wiring Diagram	3-5
4-1	DC Power Supply and Analog Meter Adjustments	4-33
4-2	ILCA Drive Test Setup	4-43
4-3	Gyro Test Setup and Test Aid	4-47
4-4	CPT Monitor Test Setup	4-50
5-1	AFCS Line Test Set Assembly	5-10
5-2	Cable Assy	5-12
5-3	Panel Assy	5-14

LIST OF TABLES

Table	Title	Page
1-1	AFCS Line Test Set Leading Particulars	1-4
1-2	Test Set Controls and Indicators	FO-4
1-3	Digital Multimeter Mode and Range Select Data	1-29
2-1	Test Set Controls and Indicators	2-4
2-2	Test Set Initial Switch Positions	2-13
3-1	Consumable Materials (AVUM)	3-2
4-1	Consumable Materials (AVIM)	4-30

NOTE

Page identification for foldout pages has been designated as FO-1, FO-2, etc. and the pages are placed in the back of the manual at time of printing. Upon receipt of this manual, insert foldout page FO-4 after page 1-8. Insert foldout pages FO-9 through FO-21 after page 4-2.

Chapter 1

INTRODUCTION

SECTION I GENERAL INFORMATION

1-1. General.

This manual contains operation and maintenance instructions for the Advanced Flight Control System (AFCS) Line Test Set 145 G0009- 1. (See fig. 1-1.) The operational information provided is intended to provide personnel with an understanding of the purpose and functions of various circuits contained in the test set without including external circuits with which they interface in normal testing. Maintenance information is intended to provide sufficient knowledge to fully support testing, troubleshooting, and repair of the test set.

1-2. Purpose.

The test set is used for conducting flight-line maintenance of the CH-47D helicopter AFCS in field operations. In place of the AFCS computer, it provides drive and excitation signals to drive/monitor AFCS components.

1-3. Reports of Maintenance and Unsatisfactory Equipment.

Use equipment forms and records in accordance with instructions in DA PAM 738-751.

1-4. Reporting of Equipment Manual Improvements.

The reporting of errors, omissions, and recommendations for improving this publication by the individual user is encouraged. Reports should be submitted on DA Form 2028 (Recommended Changes to Publications) and forward direct to Commander, U.S. Army Aviation and Troop Command, 4300 Goodfellow Blvd., St. Louis, MO 63120-1798, ATTN: AMSAT-I-MDO.

1-5. Temporary Storage.

Storage of equipment issued to, and used by, Army activities shall be in accordance with TM 1-1500-204-23 Series and TB 750-25-1.

1-6. Destruction of Army Equipment to Prevent Enemy Use.

Destruction of Army equipment to prevent enemy use shall be in accordance with TM 750-244-2.

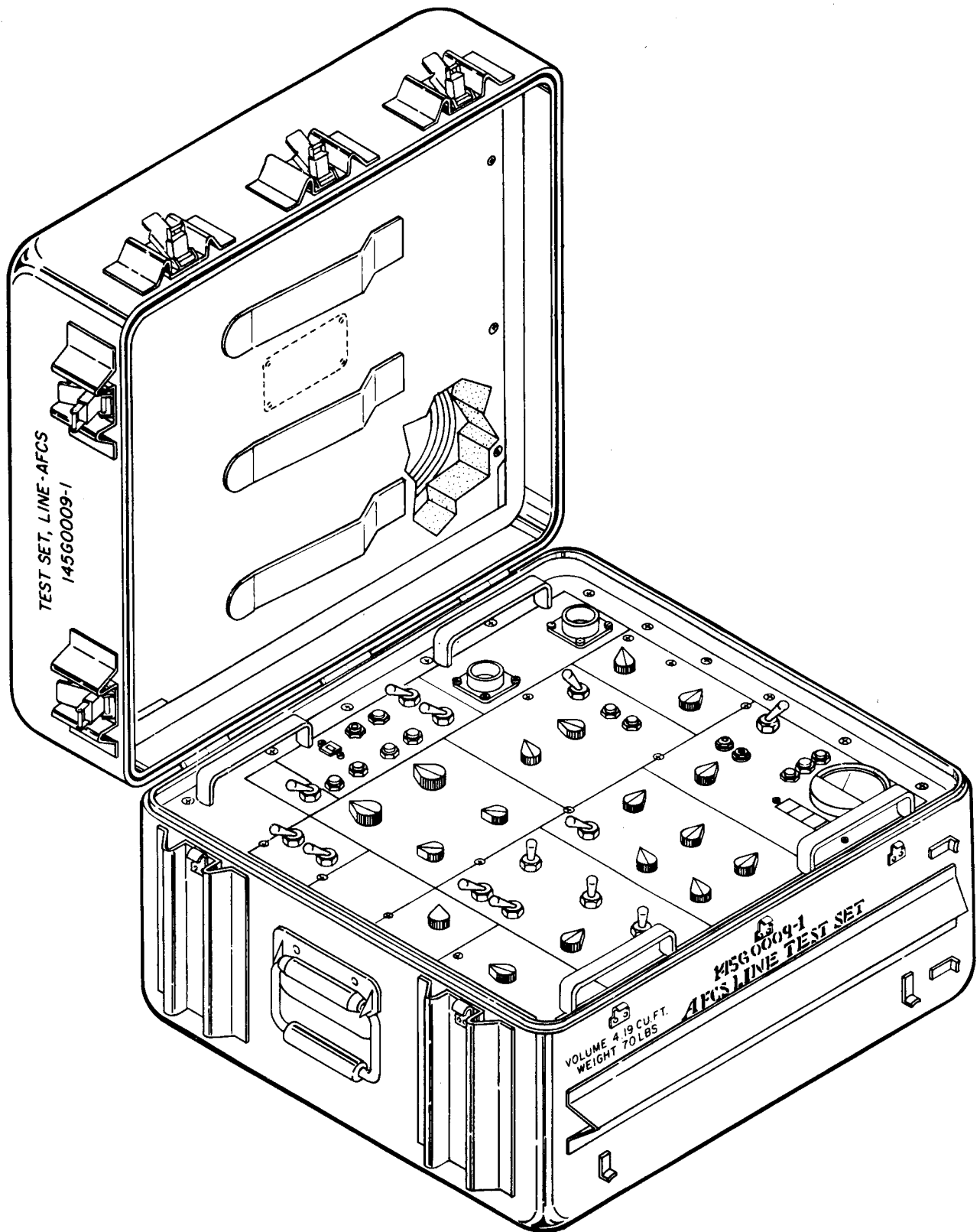

470-TMDE-ALTS-21

Figure 1-1. AFCS Line Test Set

1-7. Notes, Cautions and Warnings.

Warnings, cautions, and notes emphasize important and critical instructions. They are defined as follows:

WARNING

An operating procedure or practice which, if not correctly followed, will result in personnel injury or loss of life.

CAUTION

An operating procedure or practice which, if not strictly observed, will result in damage or destruction of equipment.

NOTE

An operating procedure or condition which it is essential to highlight.

1-8. Function.

The test set consists of various independent test circuits that share a common multimeter display and common power supplies. The test set provides drive voltages to operate external valves and actuators and excitation voltages for external position transducers. Position and feedback signals from transducers are used to monitor the positions of controls and actuators. Signals from gyro synchros are used to monitor the output of heading and attitude gyros.

SECTION II EQUIPMENT DESCRIPTION AND DATA

1-9. Description and Data.

The test set is suitcase-type, containing a control panel and three cable assemblies. (See fig. 1-1.) Operating power for the test set is supplied from the helicopter AFCS under test through the interconnecting cables.

Table 1-1. AFCS Line Test Set Leading Particulars

Dimensions (approximate):	
Height	14 inches
Width	23.5 inches
Depth	22 inches
Weight (approximate)	70 pounds
Power Requirements (obtained from helicopter circuits):	
Main AC Input	115 Vac, 400 Hz, 5A
Main DC Input	28 Vdc, 5A
Cyclic Trim DC Input	28 Vdc, 7.5A
Signal Outputs:	
+28 Vdc	-7 Vdc
+12 Vdc	13 Vac
+7 Vdc	26 Vac

1-10. Items Furnished.

In addition to the case and cover, the following cables are furnished:

Cable Assy (W1)	145G5211-1
Cable, ILCA (W2)	145G5212-1
Cable Assy (W3)	145G5213-1

1-11. Tools and Test Equipment Required.

No tools or test equipment are required for operation of this test set.

SECTION III TECHNICAL PRINCIPLES OF OPERATION

1-12. Block Diagram.

(See fig. 1-2.) The test set consists of several independent test circuits and common digital multimeter, analog meter, and power supplies. Through these power supplies, the test set provides drive voltages to operate external valves and actuators and excitation voltages for external position and feedback transducers. Signals from position transducers are used to monitor position of cockpit controls. Signals from gyro synchros are used to monitor the output of various helicopter gyros. The test set contains the following circuit cards:

a. Discrete Signal Monitor CCA A3. Contains three servo loop amplifiers and demodulators. These control closed loop operation of pitch, roll, and yaw ILCA. They also normalize signals through a program function-select logic of discrete-signal inputs from various helicopter systems.

b. Digital Multimeter CCA A2. Processes and converts information for the digital display and analog meter. It first establishes the value of measured variables. It then converts those values to equivalent BCD codes and analog signals.

c. Digital Display CCA A1. Decodes BCD data from CCA A2 and displays its numerical value on dmm. This card also contains auto-ranging circuits that dynamically adjust the measuring circuits for increasing/decreasing values.

1-13. Discrete Signal Monitor Circuit.

(See FO-2 and FO-8.) The discrete signal monitor enables selective monitoring of various helicopter functions through position or feedback signals routed to the test set. A selected signal is first normalized to the range of threshold detector circuits. Following that, it is tested to determine whether active or inactive states are acceptable. Normalizing is accomplished through the program function-select logic of discrete signal monitor circuit card A3. The logic consists of a matrix of *nand* gates and inverters. These selectively drive various independent sections of electronic switches U11, U12, and U14 in response to an active low (-8.66 volt dc) input signal on one of the program input lines. (Refer to table 1-2.) Each of the electronic switch sections controls the open/closed condition of a specific signal path in the normalizing circuits.

a. Normalizing of discrete signals includes several processes. It includes conversion of ac signals to dc equivalents. It includes amplification of signals for appropriate scaling. It includes inverting and offsetting signals where required. It includes selecting a logic ground (0 volt) or a +7.5-volt dc level. The combination of normalizing functions required for an input signal is selected by the SIGNAL SEL 1 or the SIGNAL SEL 2 switch. The actual value of any discrete signal selected for input to the discrete signal monitor can be monitored on the dmm.

b. The helicopter test signals selected by the discrete signal monitor switches are applied to pins 51 and 53 of card A3. Resistors R57, 63, 64, and 66 establish the gain of the input differential amplifier at -0.215. Diodes CR5 thru CR8 provide input protection. If the signal at U2-7 is dc, it is selected through contacts of electronic switch U11-3, 4. If the signal at U2-7 is ac, the demodulated signal is selected. From U2-7 the ac signal is demodulated. The demodulator rectifies, integrates, and provides a signal gain of 1.1. The output of the demod at U2-8 is the dc equivalent of the ac rms value. This signal is selected through contacts 1 and 2 of switch U11 whenever the input signal is ac.

TM 55-4920-429-13

c. The next stage, a programmable gain amplifier, is controlled by a logic decoder. The signal is scaled and may be inverted and offset, depending on its type. Thus the signal at U14-9 or U14-3 is normalized to a range of 0 to 5 volts dc.

d. If the signal is less than 0.76 volt, the lower-limit threshold detector turns on and closes relay K2. Relay K2 lights the STATUS B indicator. If the signal is greater than 4.60 volts, the upper-limit threshold detector turns on and closes relay K1. Relay K1 lights the STATUS A indicator. If the normalized signal for either state is between these upper and lower limits, neither status indicator will light.

1-14. Ac/Dc Amplifier.

(See FO-2, FO-3, and FO-8.) The ac/dc amplifier provides scaling of all input signals to less than one-fourth of initial amplitude. With the external signal path closed, gain of the amplifier is -0.215. With the external signal path open and resistor R62 connected to logic ground or to +7.5 vdc, the gain of the amplifier is -0.150. Diodes CR6 and CR8 limit the difference between its two input pins to 0.6 volt dc. Diodes CR5 and CR7 limit the difference between the two input pins and logic ground to 8.6 volts dc.

1-15. Ac to Dc Converter.

(See FO-2, FO-3, and FO-8.) The ac to dc converter rectifies, amplifies, and filters the 400 Hz ac input signals. This enables monitoring by the dc threshold detectors. The output of the circuit is a negative dc signal, equivalent to the rms value of the ac input signal. The ac to dc converter circuit consists of two amplifier stages. The first stage is a half-wave rectifier/amplifier. The second stage is an integrating amplifier that provides full-wave rectification and filtering of the ac input signal.

1-16. Programmable-Gain Amplifier.

(See FO-2, FO-3, and FO-8.) The programmable-gain amplifier provides final scaling of the input signal before it is applied to the threshold-detector circuits. The scaling is done directly or through offset/inverter amplifier. The gain of the amplifier is a function of which one of its four input resistors is switched into the input signal path:

$$\text{Gain} = \frac{R_{98}}{R_1} \times (-1)$$

Where R_1 = R78, R88, R89, or R90

With R78 selected, gain = -1.0 (Program 1).

With R88 selected, gain = -1.9217 (Program 2).

With R89 selected, gain = -2.1047 (Program 3).

With R90 selected, gain = -6.6566 (Program 5/7).

Capacitor C20 minimizes electrical noise in the dc input signal.

1-17. Offset/Inverter Amplifier.

(See FO-2, FO-3, and FO-8.) The offset/inverter amplifier provides offset inversion of scaled input signals for program 5. (Refer to table 1-2.) This offset inversion correlates the active and inactive states of input signals and the limits of the threshold detector circuits. The active state of input signals is 0 volt. The inactive states are +7.5 volts dc and +24 volts ac. With 0 volt input to the offset/inverter amplifier, its output applies +5.48-volt dc to the threshold-detector circuits to cause the STATUS A indicator to come on. Any positive value of input signal greater than 0 volt is proportionally subtracted from the +5.48 volt dc offset output of the amplifier through inverter action. For example: application of +5.16-volt dc (scaled value for a 24-volt ac inactive state) results in a +0.32 volt dc signal. This input to the threshold-detector circuits causes the STATUS B indicator to come on.

1-18. Threshold-Detector Circuit.

(See FO-2, FO-3, and FO-8.) The threshold-detector circuits contain two threshold-detector amplifiers and two lamp-driver stages. These control the on/off condition of the STATUS A and STATUS B indicators.

a. The STATUS A threshold detector amplifier U4-9 is biased to +4.6 volt dc at its inverting input by voltage divider R81/R82. When the input signal is below 4.6-volt dc, the output at U4-8 is -12-volt dc. When the input signal is above 4.6-volt dc, the output is +12-volt dc. When the output is negative, transistor Q6 is cut off, and relay K1 is deenergized. The ground return of STATUS A indicator thru normally-open contacts 3, 4 is open, and the indicator is out. When the output is positive, transistor Q6 is turned on, and relay K1 is energized to light the indicator. Diode CR11 protects transistor Q6 from the voltage self-induced when relay K1 is released.

b. The STATUS B threshold circuit operates the same as the STATUS A circuit, except that a +0.76 volt dc bias voltage is applied to the non-inverting input of the amplifier at U4-12. Its output voltage at U4-14 switches positive when input voltage drops below +0.76 volt dc.

c. The ground return path to the indicators thru relays K1 and K2 is open with the SEL 1/OFF/SEL 2 switch at OFF. This prevents spurious lighting of the indicators when the discrete signal monitor is not in use. Buffer diodes CR13 and CR14 provide an alternate ground-return during self-test.

1-19. Discrete Signal Monitor Programs.

(See FO-3 and FO-8. Refer to table 1-2.)

a. *Program No. 1.* Selected for monitoring CYCLIC MAG BRAKE ON, CLTV MAG BRAKE ON, SWIVEL LOCKED, and AFCS ENGAGE ON signal functions for +28 volt dc or open circuit. Program 1 uses the ac/dc amplifier, programmable-gain amplifier (gain -1.0), and threshold-detector.

(1) An active-low signal on this input line is applied to matrix inputs U7-11 and U7-1. This causes electronic-switch sections U11-6, 8, 9 and U14-13, 1, 2 to turn on. It allows electronic-switch sections U11-5, 4, 3 and 14-6, 8, 9 to be activated.

(2) U11-8,9 contacts connect resistor R62 to logic ground. This provides a 0 volt dc input level to the ac/dc amplifier when the +28 volt dc signal is inactive (open circuit). U1 1-473 contacts bypass the ac to dc converter.

(3) U14-1, 2 contacts connect the output of the ac/dc amplifier to the programmable-gain amplifier thru resistor R78.

(4) U14-8, 9 contacts bypass the offset/inverter amplifier.

b. *Program No. 2.* Selected for monitoring L ROLL BEEP TRIM ON and R ROLL BEEP TRIM ON signal functions for 13 volts ac or open circuit. Program 2 provides an ac mode signal for the dmm. It uses the ac/dc amplifier, ac to dc converter, programmable-gain amplifier (gain -1.92), and threshold-detector.

(1) An active-low signal is applied to matrix inputs U7-13, U8-12, and U10-1. This causes electronic switch sections U11-6, 8, 9, U11-U13, 1, 2 and U12-6, 8, 9 to turn on. It also causes section U11-5,4, 3 to turn off, and allows electronic-switch section U14-6, 8,9 to be activated. Transistor Q5 is turned on to energize relay K3. Relay K3 connects an ac mode level to the METER SOURCE switch. When the METER SOURCE switch is set to DISCRETE MON, the dmm displays the ac signal.

(2) U11-8,9 contacts connect resistor R62 to logic ground. This provides a 0-volt dc input level to the ac/dc amplifier when the 13 volt ac signal is inactive (open circuit).

(3) U11-4,3 contacts open. This opens the bypass around the ac to dc converter.

NOTE

Page identification for foldout pages has been designated as FO-1, FO-2, etc. and the pages are placed in the back of the manual at time of printing. Upon receipt of this manual, insert foldout pages FO-4 after page 1-8.

(4) U11-1,2 contacts close. This inserts the ac to dc converter into the signal path.

(5) U12-8, 9 contacts close. This connects the output of the ac to dc converter stage to the programmable-gain amplifier.

(6) U14-8, 9 contacts close. This bypasses the offset/inverter amplifier.

c. Program No. 3. Selected for monitoring the HDG ENGAGE ON, BARO ALT ENGAGED, RADAR ALT ENGAGED, L LDG GEAR ON GND, and R LDG GEAR ON GND for 12 volt dc or open circuit. Program 3 uses the ac/dc amplifier, the programmable-gain amplifier (gain -2.1047), and the threshold-detector.

(1) An active-low signal on this input line is applied to matrix inputs U7-12 and U10-12, 13. This causes electronic-switch sections U11-6, 8, 9 and U12-12, 10, 11 to turn on. It also allows electronic-switch sections U11-5, 4, 3 and U14-6, 8, 9 to be activated.

(2) U11-8,9 contacts connect resistor R62 to logic ground. This provides a 0 volt dc input to the ac/dc amplifier when the +12 volt dc input signal is inactive (open circuit).

(3) U11-4,3 contacts close. This bypasses the ac to dc converter.

(4) U12-10, 11 contacts close. This connects the ac/dc amplifier to the programmable-gain amplifier.

(5) U14-8, 9 contacts close. This bypasses the offset/inverter amplifier.

NOTE

Programs No. 4, 6, and 8 are not used and are non-interfering.

d. Program No. 5. Selected for monitoring the BIT ENABLE STOP, HYDR PRESSURE FULL, and VERT GYRO VALID for a ground or open circuit. Program 5 uses the ac/dc amplifier, the programmable-gain amplifier (gain -6.6566), the offset/inverter, and the threshold-detector circuits.

(1) An active-low signal on the input line is applied to matrix inputs U8-8, 9, U10-5, and U7-3. This causes electronic switch sections U11- 12, 11, 10, U12-5, 4, 3 and U14-5, 4, 3 to turn on. It also causes section U14-6, 8, 9 to turn off. Electronic-switch section U11-5, 4, 3 will be activated.

(2) U11-11,10 contacts connect resistor R62 to voltage divider R55 and R56. This provides a +7.5 volt dc input level to the ac/dc amplifier when the input signal is inactive (open-circuit).

(3) U11-4, 3 contacts close. This bypasses the ac to dc converter.

(4) U12-4, 3 contacts close. This connects the ac/dc amplifier to the programmable-gain amplifier.

(5) U14-8, 9 contacts open. This disconnects the offset/inverter amplifier bypass.

(6) U14-4, 3 contacts close. This connects the offset/inverter amplifier into the signal path.

e. Program No. 7. Selected for monitoring RADAR ALT SELF TEST GO and RADAR ALT VALID for 4.5-volt or 0-volt dc. Program 7 uses the ac/dc amplifier, programmable-gain amplifier (gain -6.6566), and threshold-detector.

(1) An active-low signal is applied to matrix input U10-6. This causes electronic-switch section U12-5, 4, 3 to turn on, and allows electronic-switch sections U11-5,4, 3 and U14-6, 8,9 to be activated.

(2) U11-4, 3 contacts close. This bypasses the ac to dc converter.

(3) U12-4, 3 contacts close. This connects the ac/dc amplifier to the programmable-gain amplifier.

1-20. Extensible-Link Servo-Control Circuit.

(See FO-4, 1-2, 1-3 and FO-6.) The extensible-link servo-control circuits contain three independent closed-loops that provide position control over the pitch, roll, and yaw extensible links (actuators).

TM 55-4920-429-13

a. Each servo-control circuit sums a feedback signal from its respective actuator-position transducer with a selected command signal. Until the feedback signal balances the command signal, a polarized drive current is applied to the actuator control valve. This current drives the actuator toward command position. As the actuator approaches command position, the level of the feedback signal increases and valve-drive current decreases. At command position, the feedback signal balances the command signal. At this point, the actuator stops.

b. Five command levels are provided for each servo-control circuit. These commands center or extend or retract the actuators to 85 percent or hardover in either direction.

c. The feedback signal for each servo-control circuit is an ac voltage. This voltage increases from zero to maximum amplitude as the actuator moves from center position to retracted or extended. The signal is in-phase or 180° out-of-phase. When the actuator retracts, the feedback signal is in-phase. When the actuator extends, the feedback signal is 180° out-of-phase. The feedback signal is demodulated into its negative or positive dc equivalent before being summed with its command signal.

1-21. Square-Wave Generator.

NOTE

Because the three servo-control circuits are identical except for input-signal scaling, only the yaw circuit is described. A summary of input-signal scaling for all three circuits is provided.

a. (See FO-4, FO-6, and FO-8.) The amplifier U2-14, 13, 12 operates as a non-inverting zero-cross detector. Output voltage switches fully positive (+12-volt dc) when reference voltage passes through zero going positive. It switches fully negative (-12-volt dc) when reference voltage passes through zero going negative. (See fig. 1-2.)

b. The square-wave output from the amplifier is inverted by U9-1, 2, 3. It is inverted again by U9-5, 6,4. This produces 180° out-of-phase 7-volt square wave at U9-3, and an in-phase 7-volt square wave at U9-4 (fig. 1-2). The output signals are used for gating the electronic switches in the demodulator.

1-22. Feedback Signal Demodulator.

a. (See FO-4, FO-6, and FO-8.) The in-phase square-wave signal from U9-4 is applied to the gating input of switch U13-13, 1, 2. The out-of-phase square-wave signal from U9-3 is applied to the gating input of switch U13-5, 4, 3. These switches turn on during the positive halves of their gating signals. They turn off during the negative halves.

b. When an in-phase retract signal is applied to resistor R5, positive half cycles are applied through U13-1, 2 contacts to the inverting input at U1-6. The negative half cycles are applied through U1 3-4,3 contacts to the non-inverting input at U1-5.

c. When an out-of-phase extend feedback signal is applied to resistor R5, the negative half cycles are applied to the inverting input of the amplifier. The positive half cycles are applied to the non-inverting input. (See fig. 1-2.) The output of the demodulation amplifier is the positive dc equivalent value of the feedback signal. The demodulated feedback signal is applied to resistor R6 in the input-summing network for the valve drive amplifier.

1-23. Valve-Drive Amplifier.

a. (See FO-4, FO-6, and FO-8.) The valve-drive current amplifier applies drive current to the actuator servo-valve. Current applied is in proportion to the difference between command and feedback signals. Current polarity moves the actuator in the direction that causes the feedback signal to balance the command signal. Capacitor C 1 damps out oscillations.

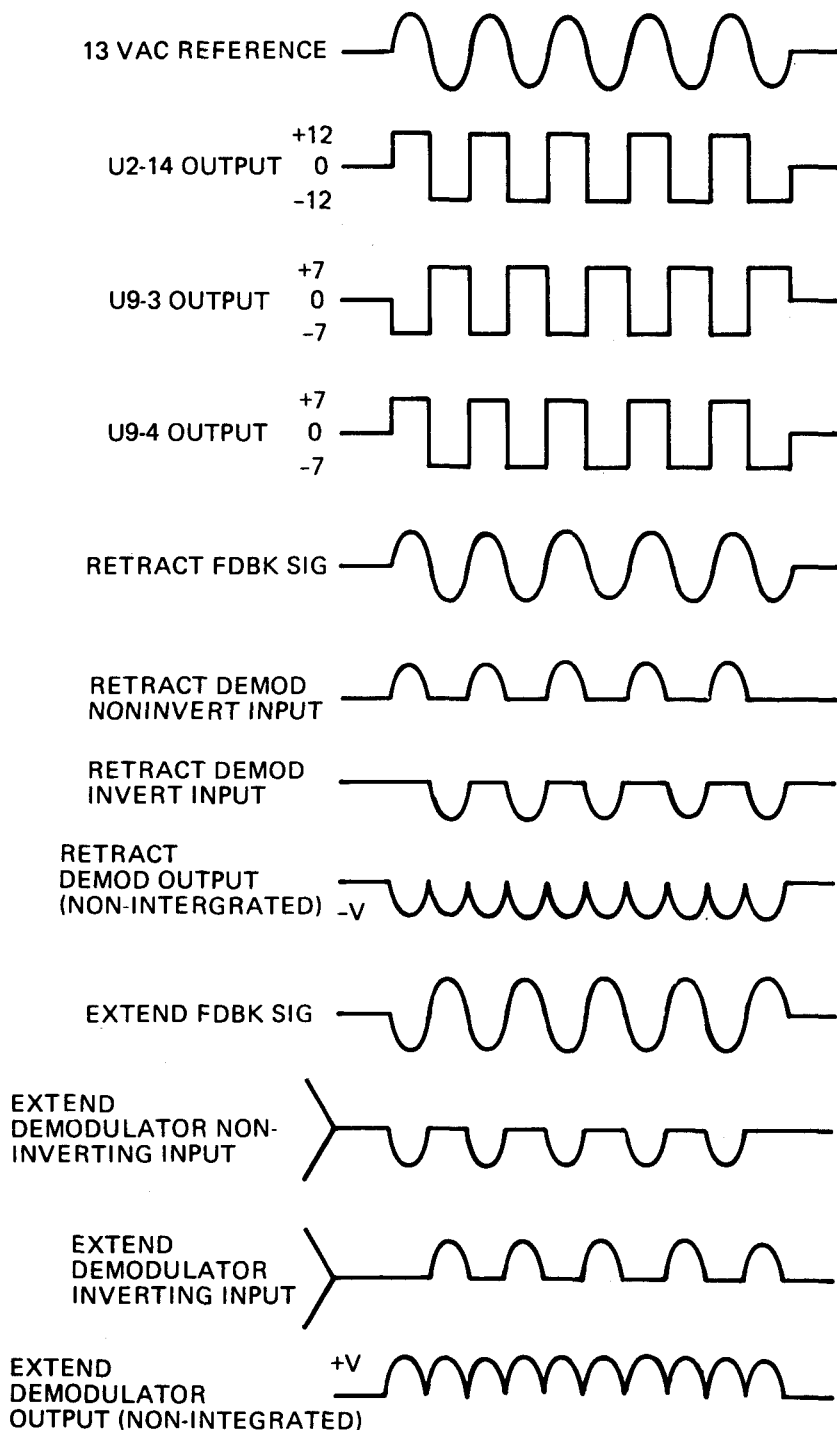

47D-TMDE-ALTS-27

Figure 1-2. Demodulation Circuit Waveforms

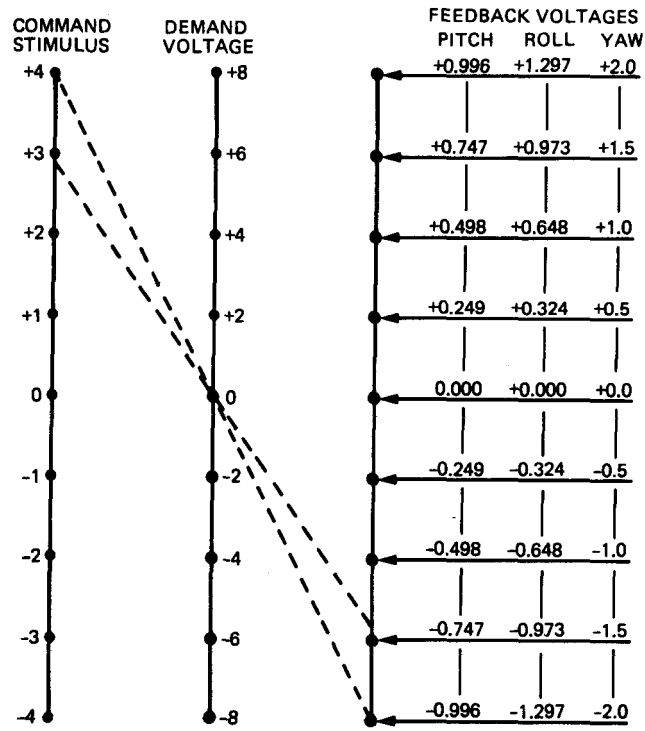

EXAMPLES:

+3.91 - - - - - 0 - - - - - -0.97337 -1.267527 -1.955
 +2.89 - - - - - 0 - - - - - -0.71945 -0.936868 -1.445

Figure 1-3. Comparison of Command, Feedback, and Demand Voltages

b. With the 2000 ohm valve load connected between the valve-drive outputs, amplifier output is + 3.299 volts dc. The gain of the amplifier is linear throughout its operating range. Output current is the same for 1 volt of command plus 0 volt of feedback or for 0 volt of command plus 0.5 volt of feedback. Valve-drive current varies inversely with the value of the command input resistor. The ratios of output current to demand voltage for the three circuits are as follows:

- Yaw: 1.556 ma per demand volt
- Roll: 1.008 ma per demand volt
- Pitch: 0.7747 ma per demand volt

c. A graph of command voltage and feedback voltage versus demand voltage is provided in fig. 1-3. Several instantaneous values of command voltage and feedback voltage are plotted to indicate the corresponding instantaneous demand voltage.

1-24. Digital Multimeter CCA A2.

(See FO-7 and FO-8.) This circuit encodes input signals that are sent to digital display CCA A1. Card CCA A2 includes analog and digital sections.

a. *Analog.* Analog inputs cause the meter to indicate in ac volts, dc volts, or K-ohms. There are four ranges for each mode.

(1) Mode selection is controlled by relays K5 and K6. K5 and K6 are operated by input signals OHM SEL- and AC SEL- gates U17-12, 13 and U17-4, 5. The gates provide decoding and control relay operation. Without a logic ground at the mode inputs, the circuits measure dc voltage.

(2) The meter measures unknown voltage (VX) within the range of the reference voltage (Vref). Range selection is controlled by relays K1, K2, K3, K4, K10 and analog multiplexer (4053B) U19X and U19Y. Table 1-3 gives the status of relays K1 through K10 for each range in each mode. The table also gives the Vref supplied to U20, pin 2, and the constant current supplied by VR2 to the unknown resistance in K-ohms mode.

Table 1-3. Digital Multimeter Mode and Range Select Data

MODE	RANGE	RELAYS										CURRENT		
		K1	K2	K3	K4	K5	K6	K7	K8	K9	K10	VREF	SOURCE	
K OHMS	0 to 1.999K					x					x		2.0V	1000 ua
	2.0 to 19.99K					x					x	x	2.0V	100 ua
	20 to 199.9K			x		x					x		2.0V	10 ua
	200 to 1999K		x	x		x					x		2.0V	1 ua
ACV	0 to 0.1999						x	x					0.2V	
	0.2 to 1.999						x	x					2.0V	
	2.0 to 19.99				x		x	x					2.0V	
	20 to 199.9	x			x		x	x					2.0V	
DCV	0 to 0.1999									x			0.2V	
	0.2 to 1.999									x			2.0V	
	2.0 to 19.99				x					x			2.0V	
	20 to 199.9	x			x					x			2.0V	

X = relay energized.

(3) With dc inputs (no logic ground), the lowest voltage range is +0.1999-volt dc. With K1 deenergized (voltage dividers R23, R25, R26, and R27 are not in the circuit), U19Y selects a Vref of 0.20 volt through voltage divider R4, R5, and R6, and U19Y. R11 is also selected by U19X when Vref is 0.20 volt, providing a 0.2 volt reference to A/D converter U20.

(4) For the 0.2 to 1.999 volt range, 2.0 volt range is selected through U19Y (Y1) and U19X (X1). With K1 deenergized, voltage divider R23, R25, R26 and R27 are not in the circuit. The 2.0 volt reference provides ± 1.999 volts full scale and is the basic mode and range for CCA A2.

(5) The 2 to 19.99 and 20 to 199.9 volt ranges provide the same 2.0 volt reference. Relay K1 becomes energized allowing the input voltages to be divided by 10 or 100. This increases the range of the meter to ± 19.99 volts or ± 199.9 volts full scale, while the input to the A/D converter U20 is 2.0 volts. Relay K8 will cause VDC lamp to come on.

(6) Ac voltage is measured as phase-sensitive polarity, + for in-phase and - for 180° out-of-phase. The reference phase AC REF+ and AC REF- is applied to comparator U25, which controls analog mux U19Z. The ac input signal is buffered by op-amp U26. The signal is switched through U19Z to the+ or - input of ac averaging circuit U7-13, 12. The rectified average value is scaled to the rms value through U7-2, 3. It is applied to analog meter M2 through U27. For ac inputs, all relays and switches operate the same as on dc, except that relay K6 is energized by a logic ground (AC SEL-). Relay K7 lights the VAC lamp.

(7) For K-ohms measurements, a constant current is applied to the unknown resistance (RX) and the voltage is measured as dc. Constant current is provided by VR2 and applied through resistor R35, R18, R19 or R21. The constant current for each range is given in table 1-3.

(8) The external meter driver is made up of U27, R28, and R30. R28 and R30 are switched by K4.

(9) Voltage clamp protection is provided for U26. U7-7 and U7-8 provide +3.5 volts and -3.5 volts. Diodes CR6 and CR7 provide the clamping action when the voltage at U26-3 is about ± 4.2 volts dc.

b. Digital. The multiplexed binary-coded-decimal (BCD) data output of A/D converter U20 is first buffered (U21 and U23), then strobed into a set of quad latches U6,U12,U11, and U5.

(1) Digit 1 data (D IA) at U5 is encoded with sign and ± 10 digit overflow and underflow bits. The overflow/underflow conditions increment/decrement auto range counter U3 through direction pulse generator U4-8/6, U10-2, U8-6, and U16-4.

(2) The direction pulse generator is started by an end of conversion (eoc) from U20, which sets U10-5 to 1. This is *anded* with DS2 from U20 to produce a pulse only during the first DS2 after eoc. This pulse is *anded* (U4) with outputs of U5-2, 14 and an inhibit signal from U9-3. The inhibit signal prevents counting *up* from the highest range or *down* from the lowest range.

(3) Auto range counter U3 is a binary up/down counter. Only two bits, A and B, are used.

(4) U9 is a BCD-to-decimal decoder with only two inputs used.

(5) Decimal point controller U15 is a data selector that selects the proper decimal point for the volts or ohms mode. For K-ohms mode, the decimal is shifted 1 place to the right.

(6) Over-range decode logic U8-9, 10, 11 detects an over-range condition on the highest range available. An over-range condition causes square wave at U10-8 to be gated onto the over-range decode logic. The output signal BLANK+ causes the digital display to flash for any out-of-range condition.

1-25. Digital Display CCA A1.

(See fig. 1-4 and FO-8.) The digital display card decodes BCD data from dmm card A2 and displays 3½ digits, the sign, and decimal point. Out of range conditions are indicated by flashing display.

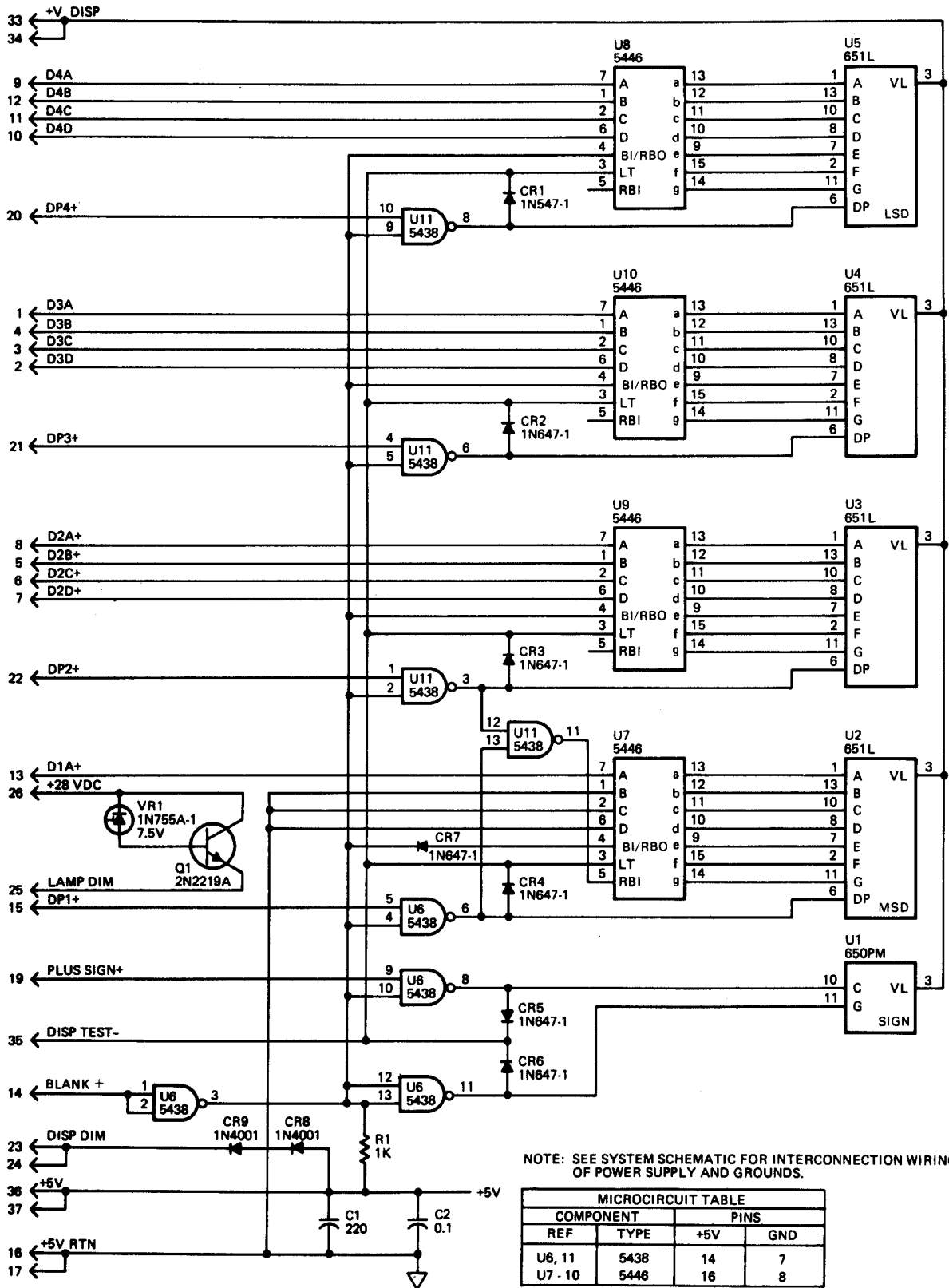

NOTE: SEE SYSTEM SCHEMATIC FOR INTERCONNECTION WIRING OF POWER SUPPLY AND GROUNDS.

MICROCIRCUIT TABLE			
COMPONENT	PINS		
REF	TYPE	+5V	GND
U6, 11	5438	14	7
U7 - 10	5446	16	8

NOTE
 1. UNLESS OTHERWISE SPECIFIED, RESISTANCE VALUES ARE IN OHMS AND CAPACITANCE VALUES ARE IN MICROFARRADS.

Figure 1-4. Digital Multimeter Display Schematic Diagram

a. A ground logic 0 at LT (pin 3) of the BCD decoders U7-U10 causes all segments to be on. This is used for self-test of the display indicators. The source of the signal is DISP TEST-.

b. A ground logic 0 at BI/RBO of the decoder causes all segments to be off. This input is used to flash all lights, indicating an over-range condition. The origin of the signal is BLANK+ from CCA A2.

c. A ground logic 0 at RBI of the MSD, U7-5, will cause the output to be off (blank) if the output would normally be a decimal zero. This occurs when decimal point DP 3 or DP4 is on.

d. Decimal points are controlled by inputs to the digital display from CCA A2.

e. The plus/minus sign (U I) is positive when PLUS SIGN+ signal is a logic 1.

f. Display indicators are dimmed by connecting DISP DIM to +V DISP through DISPLAY, . BRIGHT/DIM switch. Voltage is reduced by CR8 and CR9.

g. The VDC, VAC, K-OHMS, STATUS A, and STATUS B indicators are dimmed by connecting LAMP DIM to mode indicators. Voltage is reduced by VR1 and Q1.

Chapter 2

OPERATING INSTRUCTIONS

SECTION I PREPARATION FOR USE

CAUTION

The AFCS test set is a delicate instrument and must be handled carefully to prevent damage which might render test set inoperative.

2-1. Unpacking Procedure.

No special unpacking procedures are required to remove the test set from the shipping container. Remove the test set from shipping container and perform the following procedure (fig. 2-1):

- a. Open the air pressure relief valve in the case to equalize inside and outside air pressures.
- b. Release seven latches and remove cover.
- c. Check the accessories stored in the cover against the list in para 1-10.

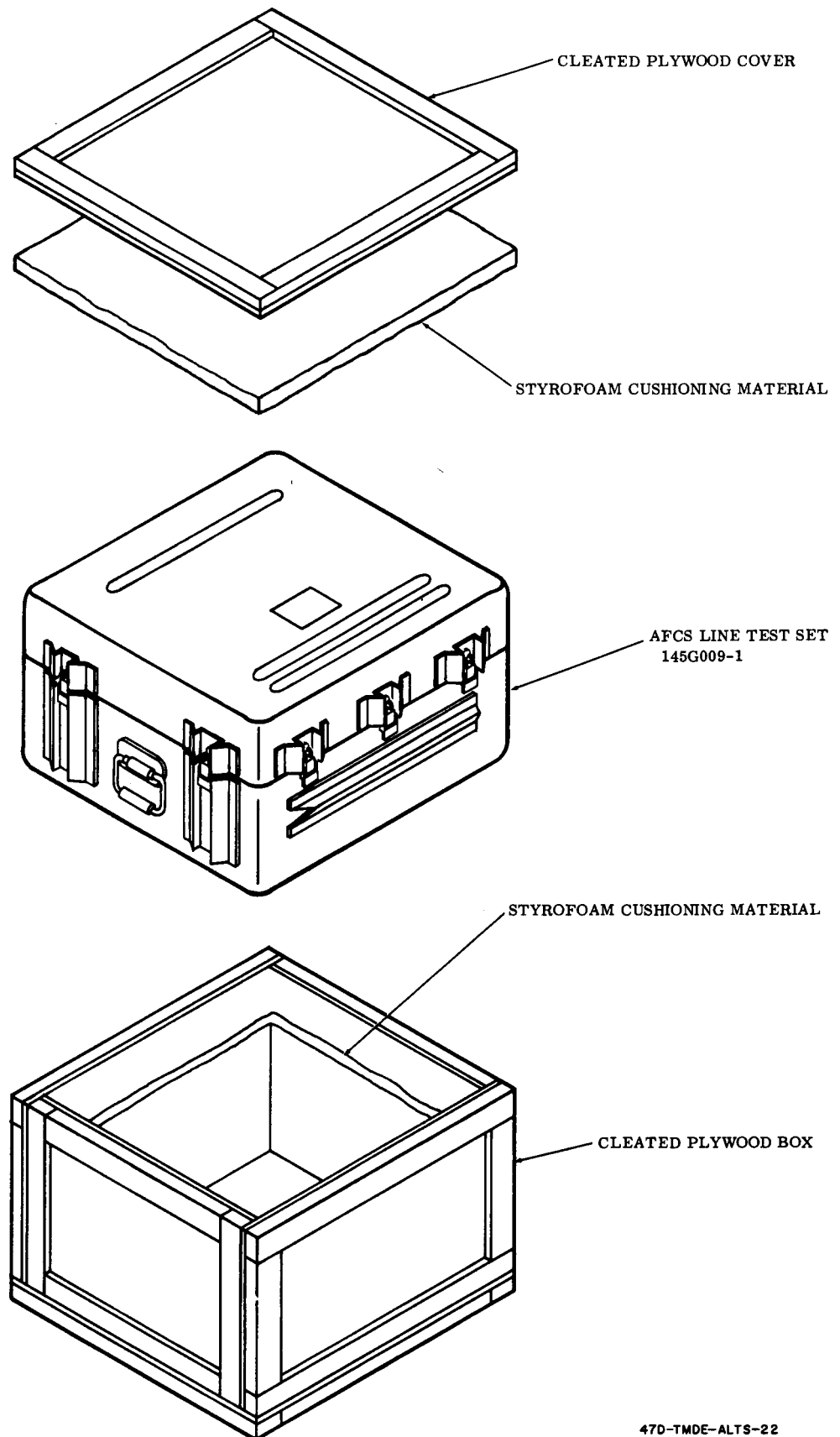

47D-TMDE-ALTS-22

Figure 2-1. Typical Packaging of Test Set

SECTION II OPERATION

2-2. DESCRIPTION AND FUNCTION OF OPERATORS CONTROLS AND INDICATORS.

The panel and the circuits of the test set are divided into 11 distinct sections, as indicated by the grouping of switches and indicators on the test set front panel. (See fig. 2-2.) The panel also includes two binding posts, HI (TP1), LO (TP2), and two cable receptacles, J1 and J3. The switches and indicators in each of these sections are listed and described in table 2-1.

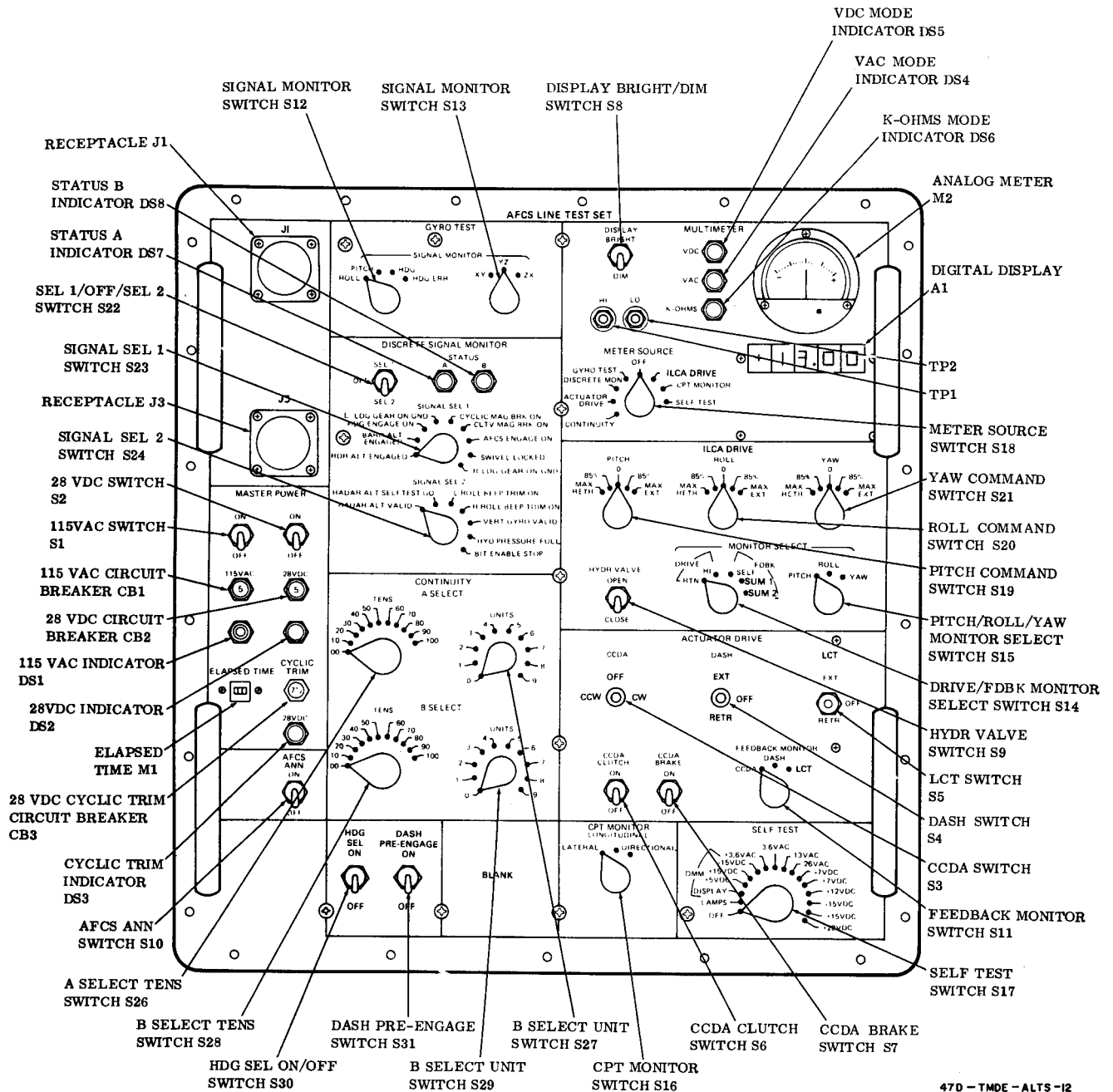

Figure 2-2. AFCS Line Test Set Controls and Indicators

Table 2-1. Test Set Controls and Indicators

CONTROL/INDICATOR	DESCRIPTION
MASTER POWER Group	Two switches, three circuit breakers, and three indicator lights used to control and indicate status of input power.
115 VAC circuit breaker CB1	5 ampere circuit breaker. Protects 115 vac 400 Hz power circuits from overload.
115 VAC MASTER POWER switch S1	Provides ON/OFF control of 115 vac 400 Hz power.
115 VAC indicator DS1	Indicator light. Indicates when 115 vac power is applied to test set through S1.
ELAPSED TIME indicator (ETI) MI	Indicates total time, to 9,999 hours, that test set has been energized.
28 VDC circuit breaker CB2	5-ampere circuit breaker. Protects 28 vdc power circuits from overload.
+28 VDC MASTER POWER switch S2	Provides ON/OFF control of 28 vdc power.
28 VDC indicator DS2	Indicator light. Indicates when 28 vdc power is applied to test set.
28 VDC CYCLIC TRIM circuit breaker CB3	7.5-ampere circuit breaker. Protects cyclic trim 28 vdc circuits (external to test set) from overload.
CYCLIC TRIM 28 VDC indicator DS3	Indicator light. Indicates when 28 vdc power is applied to test set through CB3.
MULTIMETER Group	<p data-bbox="668 1017 1437 1108">Switch, rotary, 8-position. Selects one of 7 sources for input to multimeter, plus meter OFF. Switch positions are:</p> <p data-bbox="700 1125 1433 1183">CONTINUITY. Connects meter as ohmmeter and connects meter to CONTINUITY switches.</p> <p data-bbox="700 1199 1458 1257">ACTUATOR DRIVE. Connects meter to actuator drive circuits and to ACTUATOR DRIVE switches.</p> <p data-bbox="700 1274 1437 1332">DISCRETE SIGNAL MONITOR. Connects meter to signal monitor circuit.</p> <p data-bbox="700 1348 1110 1373">GYRO TEST. Connects meter to gyro.</p> <p data-bbox="700 1390 963 1415">OFF. Disconnects meter.</p> <p data-bbox="700 1431 1422 1489">ILCA DRIVE. Connects meter to integrated lower control actuator drive circuits.</p> <p data-bbox="700 1506 1437 1564">CPT MONITOR. Connects meter to control position transducer circuits.</p> <p data-bbox="700 1580 1382 1605">SELF TEST. Connects meter to self-test (power supply) circuits.</p> <p data-bbox="161 1622 435 1647">VDC mode indicator DS4</p> <p data-bbox="668 1622 1123 1680">Indicator light. Comes on when meter is set to measure dc.</p> <p data-bbox="161 1696 432 1721">VAC mode indicator DS5</p> <p data-bbox="668 1696 1118 1754">Indicator light. Comes on when meter is set to measure ac.</p> <p data-bbox="161 1771 488 1796">K-OHMS mode indicator DS6</p> <p data-bbox="668 1771 1286 1829">Indicator light. Comes on when meter is set to measure ohms (continuity).</p> <p data-bbox="161 1846 352 1871">Digital display A1</p> <p data-bbox="668 1846 1442 1904">Digital meter. Displays ohms, ac or dc volts. Provides a maximum reading of ±1999 (three and one-half digits and sign.)</p> <p data-bbox="161 1920 347 1945">Analog meter M2</p> <p data-bbox="668 1920 1198 1945">Provides analog equivalent of digital display A1.</p>

Table 2-1. Test Set Controls and Indicators — Continued

CONTROL/INDICATOR	DESCRIPTION
DISPLAY BRIGHT/DIM switch S8	Switch, toggle, 2-position. Selects BRIGHT or DIM illumination of VDC, VAC, K-OHMS, STATUS A, and STATUS B indicators and the digital display.
HI and LO terminals TP1, TP2	Binding Posts. Enable connection of external meter to test set for checkout purposes. Also enable connection of test voltages for testing DISCRETE SIGNAL MONITOR group and ILCA drive group.
CONTINUITY Group	Four switches used in conjunction with CONTINUITY position of METER SOURCE switch. Connects various test points of the helicopter to the meter for a continuity measurement.
A SELECT TENS switch S26	Switch, rotary, 1 l-position. Used in conjunction with the A SELECT UNITS switch to select a test point in the helicopter and connect it to the high side of the meter.
A SELECT UNITS switch S27	Switch, rotary, 10-position. Used in conjunction with the A SELECT TENS switch to select a test point in the helicopter and connect it to the high side of the meter.
B SELECT TENS switch S28	Switch, rotary, 1 l-position. Used in conjunction with the B SELECT UNITS switch to select a test point in the helicopter and connect it to the low side of the meter.
B SELECT UNITS switch S29	Switch, rotary, 10-position. Used in conjunction with the B SELECT TENS switch to select a test point in the helicopter and connect it to the low side of the meter.
ACTUATOR DRIVE Group	Six switches used in conjunction with ACTUATOR DRIVE position of METER SOURCE switch.
CCDA switch S3	Switch, momentary. Selects cw or ccw rotation of CCDA servo motor. CW. Switch applies 2.5 vat, 400 Hz, 90° lagging (with respect to 115 vac input voltage) to servo motor. CCW, Switch applies 2.5 vat, 400 Hz, 90° leading, to servo motor. OFF. Voltage disconnected from servo motor.
DASH switch S4	Switch, momentary. Selects voltage to extend or retract actuator. EXT. Applies 28 vdc HI to actuator. RETR. Applies 28 vdc LO to actuator. OFF. Voltage disconnected from actuator.
LCT switch S5	Switch, momentary. Selects extend or retract actuator voltage. EXT. Applies cyclic trim 28 vdc to actuator extend winding. RETR. Applies cyclic trim 28 vdc to actuator retract winding. OFF. Voltage is disconnected.

Table 2-1. Test Set Controls and Indicators — Continued

CONTROL/INDICATOR	DESCRIPTION
CCDA CLUTCH switch S6	<p>Switch, toggle, 2-position. Controls CCDA clutch.</p> <p>ON. Applies 28 vdc to energize clutch and brake (independent of CCDA BRAKE switch).</p> <p>OFF. Voltage is disconnected.</p>
CCDA BRAKE switch S7	<p>Switch, toggle, 2-position. Controls ccda brake.</p> <p>ON. Applies 28 vdc to energize brake.</p> <p>OFF. Voltage is disconnected.</p>
FEEDBACK MONITOR switch S11	<p>Switch, rotary, 3-position. Selects feedback signals from position devices for CCDA, DASH, and LCT actuators for monitoring by the meter (position of actuator is indicated by polarity and magnitude of feedback-voltage reading on meter).</p> <p>CCDA. Ac feedback voltage from CCDA actuator is measured.</p> <p>DASH. Dc feedback voltage from DASH actuator is measured.</p> <p>LCT. Dc feedback voltage from LCT actuator is measured.</p>
DISCRETE SIGNAL MONITOR Group	<p>Three switches used in conjunction with DISCRETE SIGNAL MONITOR position of METER SOURCE switch.</p>
SEL 1/OFF/SEL 2 switch S22	<p>Switch, toggle, 3-position. Selects input signals for monitoring. Selected signal can also be monitored on the multimeter.</p> <p>At SEL 1, signal from SIGNAL SEL 1 switch is selected for monitoring by A and B STATUS indicators.</p> <p>At SEL 2, signal from SIGNAL SEL 2 switch is selected for monitoring by A and B STATUS indicators.</p> <p>At OFF, STATUS indicators are inhibited from lighting.</p>
SIGNAL SEL 1 switch S23	<p>Switch, rotary, 9-position. Selects discrete input signals for display when SEL 1/SEL 2 switch is at SEL 1.</p> <p>RDR ALT ENGAGED. Signal from AFCS panel is displayed.</p> <p>BARO ALT ENGAGED. Signal from AFCS panel is displayed.</p> <p>HDG ENGAGE ON. Signal from AFCS panel is displayed.</p> <p>L LDG GEAR ON GND. Signal from proximity switch is displayed.</p> <p>CYCLIC MAG BRK ON. Signal from CENTERING DEVICE RELEASE switch is displayed.</p> <p>CLTV MAG BRK ON. Signal from THRUST CONTROL MAG BRAKE TRIGGER switch is displayed.</p> <p>AFCS ENGAGE ON. Signal from AFCS panel is displayed.</p> <p>SWIVEL LOCKED. Signal from power STEERING control panel is displayed.</p> <p>R LDG GEAR ON GND. Signal from proximity switch is displayed.</p> <p>NOTE: All input signals to SIGNAL SEL 1 switch are processed through the DISCRETE SIGNAL MONITOR before being displayed.</p>

Table 2-1. Test Set Controls and Indicators — Continued

CONTROL/INDICATOR	DESCRIPTION
SIGNAL SEL 2 switch S24	<p>Switch, rotary, 7-position. Selects discrete input signals for display when SEL 1/SEL 2 switch is at SEL 2.</p> <p>RADAR ALT VALID. Signal from radar altimeter is displayed.</p> <p>RADAR ALT SELF TEST GO. Signal from radar altimeter is displayed.</p> <p>L ROLL BEEP, TRIM ON. Signal from pitch and roll trim switch is displayed.</p> <p>R ROLL BEEP, TRIM ON. Signal from pitch and roll trim switch is displayed.</p> <p>VERT GYRO VALID. Signal from vertical gyro is displayed.</p> <p>HYD PRESSURE FULL. Signal from hydraulic pressure switch is displayed.</p> <p>BIT ENABLE STOP. Signal from engine condition levers is displayed.</p> <p>NOTE: All input signals to SIGNAL SEL 2 switch are processed through the DISCRETE SIGNAL MONITOR before being displayed.</p>
STATUS A indicator DS7	<p>Indicator light (green). Lights to indicate magnitude (or closed condition) of selected discrete signal is at proper level for active state.</p>
STATUS B indicator DS8	<p>Indicator light (amber). Lights to indicate magnitude (or open condition) of selected discrete signal is at proper level for inactive state.</p>
GYRO TEST Group	<p>Two switches used in conjunction with GYRO TEST position of METER SOURCE switch.</p>
ROLL/PITCH/HDG/HDG ERR SIGNAL MONITOR switch S12	<p>Switch, rotary, 4-position.</p> <p>Used in conjunction with XY, YZ, ZX SIGNAL MONITOR switch. Selects input signals from vertical gyros, directional gyro, and hsi for monitoring on meter.</p> <p>ROLL. 400 Hz roll signals from the attitude gyros are monitored.</p> <p>PITCH. 400 Hz pitch signals from the attitude gyros are monitored.</p> <p>HDG. 400 Hz heading signals from the directional gyro are monitored.</p> <p>HDG ERR. 400 Hz heading error signal from the hsi is monitored.</p>
XY/YZ/ZX SIGNAL MONITOR switch S 13	<p>Switch, rotary, 3-position. Selects XY, YZ or ZX synchro signals pairs selected by ROLL/PITCH/HDG/HDG ERR SIGNAL MONITOR switch for monitoring on meter.</p>

Table 2-1. Test Set Controls and Indicators — Continued

CONTROL/INDICATOR	DESCRIPTION
ILCA DRIVE Group	Six switches used in conjunction with the ILCA DRIVE position of the METER SOURCE switch.
PITCH command switch S 19	<p>Switch, rotary, 5-position.</p> <p>Selects one of five discrete command signals. Command signals are used to drive the pitch extensible link. Feedback voltage, proportionate to link position, cancels input signal and stops link.</p> <p>MAX RETR. Retract signal (+3.91 vdc) drives the link to the hardover position.</p> <p>85%. Retract signal (+2.89 Vdc) drives link to standard retract input position (85%).</p> <p>O. Drive voltage is balanced (0.0 vdc) and the extensible link is at neutral.</p> <p>85%. Extend signal (-2.89 vdc) drives link to the standard extend input position (85 %).</p> <p>MAX EXT. Extend signal (-3.91 vdc) drives the link to the hardover position.</p>
ROLL command switch S20	<p>Switch, rotary, 5-position.</p> <p>Selects one of five discrete command signals. Command signals are used to drive the roll extensible link. Feedback voltage, proportionate to link position, cancels input signal and stops link.</p> <p>MAX RETR. Retract signal (+3.91 vdc) drives the link to the hardover position.</p> <p>85%. Retract signal (+2.89 vdc) drives link to standard retract input position (85%).</p> <p>O. Drive voltage is balanced (0.0 vdc) and the extensible link is at neutral.</p> <p>85%. Extend signal (-2.89 vdc) drives link to the standard extend input position (85 %).</p> <p>MAX EXT. Extend signal (-3.91 vdc) drives the link to the hardover position.</p>
YAW command switch S21	<p>Switch, rotary, 5-position.</p> <p>Selects one of five discrete command signals. Command signals are used to drive the yaw extensible link. Feedback voltage, proportionate to link position, cancels input signal and stops link.</p> <p>MAX RETR. Retract signal (+3.91 vdc) drives the link to the hardover position.</p> <p>85%. Retract signal (+2.89 vdc) drives link to the standard retract input position (85%).</p> <p>O. Drive voltage is balanced (0.0 vdc) and the extensible link is at neutral.</p> <p>85%. Extend signal (-2.89 vdc) drives link to the standard extend input position (85%).</p> <p>MAX EXT. Extend signal (-3.91 vdc) drives the link to the hardover position.</p>

Table 2-1. Test Set Controls and Indicators — Continued

CONTROl/INDICATOR	DESCRIPTION
HYDR VALVE switch S9	<p>Switch, toggle, 2-position. Controls AFCS hydraulic shutoff valve that supplies hydraulic pressure to the pitch, roll, and yaw extensible link servo valves.</p> <p>OPEN. Switch applies 28 vdc. CLOSE. 28 vdc is removed.</p>
PITCH/ROLL/YAW MONITOR SELECT switch S15	<p>Switch, rotary, 3-position.</p> <p>Selects servo-loop circuit for display of drive and feedback signal values on multimeter.</p> <p>At PITCH, pitch axis signals are connected for display. At ROLL, roll axis signals are selected for display. At YAW, yaw axis signals are selected for display.</p>
DRIVE/FDBK MONITOR SELECT switch S14	<p>Switch, rotary, 5-position. Selects test points, drive or feedback signals for axis selected by PITCH/ROLL/YAW MONITOR SELECT switch for monitoring by the meter. (Refer to notes 1 & 2.)</p> <p>DRIVE RTN. Level of extensible link drive return voltage is displayed. DRIVE HI. Level of extensible link drive voltage is displayed. FDBK SELF. Level of extensible link self feedback voltage is displayed. FDBK SUM 1. Level of extensible link summed feedback voltage at pin J1-N is displayed. FDBK SUM 2. Level of extensible link summed feedback voltage at pin J1-L is displayed.</p>
CPT MONITOR Switch	<p>Single switch used in conjunction with CPT MONITOR position of METER SOURCE switch.</p>
CPT MONITOR switch S16	<p>Switch, rotary, 3-position. Selects position signals from control position transducers.</p> <p>LATERAL. Selects lateral stick position signal from lateral cpt for display. LONGITUDINAL . Selects longitudinal stick position signal from longitudinal cpt for display. DIRECTIONAL. Selects pedal position signal from directional cpt for display.</p>
SELF TEST Group SELF TEST switch S17	<p>Switch, rotary, 16-position. Selects test or monitor functions from internal circuitry of tester.</p> <p>OFF. No self-test function. LAMPS. Provides 28 vdc lamp test return. Lights STATUS A and STATUS B indicator lights and meter DC, AC, and K-OHMS indicator lights.</p>

Table 2-1. Test Set Controls and Indicators — Continued

CONTROL/INDICATOR	DESCRIPTION
	<p>DMM DISPLAY. Provides test logic ground to light all decimal points and number segments in digital display. Provides a test reading of four 8s, each preceded by decimal point display and + sign.</p> <p>DMM +5 VDC. Monitors +5-volt supply on digital display.</p> <p>DMM +15 VDC. Monitors +15-volt supply on digital display.</p> <p>DMM -15 VDC. Monitors -15-volt supply on digital display.</p> <p>+3.6 VAC. Monitors in-phase 3.6 vac supply on meter.</p> <p>-3.6 VAC. Monitors out-of-phase 3.6 vac supply on meter.</p> <p>+13 VAC. Monitors in-phase 13 vac supply on meter.</p> <p>+26 VAC. Monitors in-phase 26 vac supply on meter.</p> <p>-7 VDC. Monitors -7 vdc supply on meter.</p> <p>+7 VDC. Monitors +7 vdc supply on meter.</p> <p>+12 VDC. Monitors +12 vdc supply on meter.</p> <p>-15 VDC. Monitors -15 vdc supply on meter.</p> <p>+15 VDC. Monitors +15 vdc supply on meter.</p> <p>+28 VDC. Monitors +28 vdc supply on meter.</p>
AFCS ANNUNCIATOR Switch	<p>Single switch which operates independently.</p> <p>Controls AFCS annunciator by connecting and disconnecting 28 vdc return.</p> <p>ON. Checks circuit and lights of AFCS annunciator.</p> <p>OFF. Disconnects ground.</p>
AFCS ANN switch S10	<p>Switch, toggle, 2-position.</p> <p>Duplicates function of HDG SEL switch on AFCS panel.</p> <p>ON. Engages heading select.</p> <p>OFF. Heading select disengaged.</p>
HDG SEL S30	DASH PRE-ENGAGE S31
DASH PRE-ENGAGE S31	<p>Switch, toggle, 2-position.</p> <p>Allows remote control of dash actuator.</p> <p>ON. Applies power to dash actuator.</p> <p>OFF. Power disconnected from dash actuator.</p>

NOTE

1. Test points selected by CONTINUITY A and B SELECT switches are internal wiring connections between contacts of switches S26, S27, S28, and S29 and all used contacts in connectors J1 and J3, with the exception of those pins used for the high side of the master power 115 VAC and 28 VDC test set inputs.
2. Only FDBK SELF signals are used in the test of their respective servo circuits; SUM 1 and SUM 2 signals are monitored only.

2-3. Operational Start Up.

a. Connection Procedure.

- (1) Disconnect ac, dc, and hydraulic power from the helicopter. Disconnect the battery.
- (2) Disconnect the helicopter cable plugs from receptacles J1 and J3 on No. 1 or No. 2 AFCS computers as required.
- (3) Connect helicopter cable plugs to the test set using cables provided in the test set. See fig. 2-3.
- (4) Check that tester switches are at initial positions as listed in table 2-2.
- (5) Connect the helicopter battery plug. Apply ac, dc, and hydraulic power to the helicopter. (Refer to TM 55-1520-240-23.)

b. Start Up Procedure.

- (1) Make sure that the following helicopter circuit breakers are closed:

No. 1 pdp

ac circuit breakers

AFCS NO. 1
CLTV DRIVER ACTR
VGI COPLT
HSI COPLT
CMPS

dc circuit breakers

AFCS NO. 1
CLTV DRIVER ACTR
CYCLIC TRIM MNL
CYCLIC TRIM FWD ACTR
CONT CENTER
BRAKE & STEER
THRUST BRAKE

No. 2 pdp

ac circuit breakers

AFCS NO. 2
HSI PLT
VGI PILOT

dc circuit breakers

AFCS NO. 2
THRUST BRAKE
CYCLIC TRIM AFT ACTR
RAD ALT
VGI CONT

- (2) On the test set, make sure that the 115 VAC and the 28 VDC circuit breakers are closed. (A white band indicates that the circuit breaker is open.) The CYCLIC TRIM 28 VDC indicator shall come on when the circuit breakers are closed.

- (3) Set the 115 VAC and 28 VDC MASTER POWER switches to ON. The 115 VAC and 28 VDC indicators shall come on.

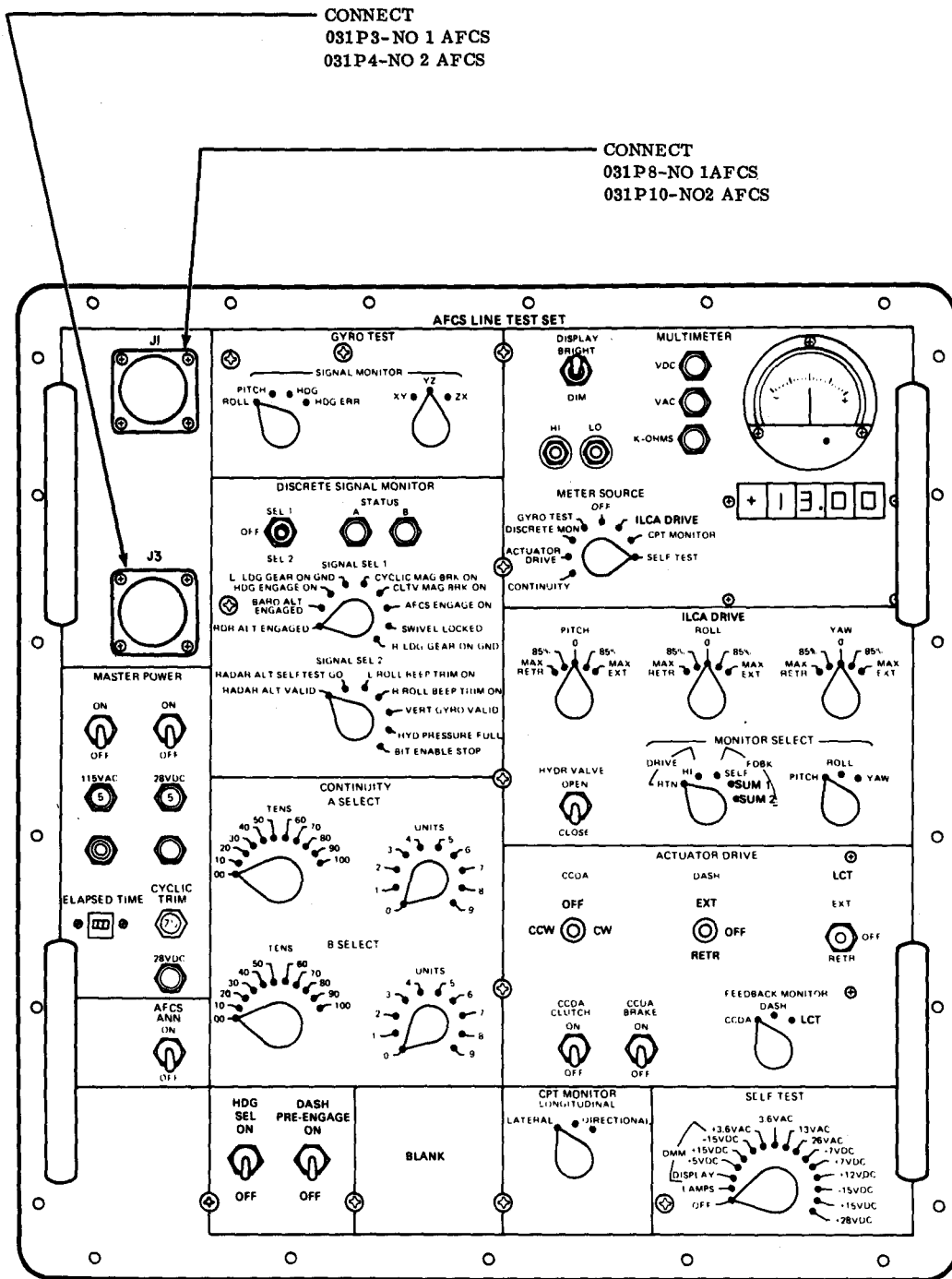

Figure 2-3. Test Set Connections to Helicopter

Table 2-2. Test Set Initial Switch Positions

SWITCH	POSITION
MASTER POWER Group	
115 VAC	OFF
28 VDC	OFF
GYRO TEST Group	
ROLL/PITCH/HDG/HDG ERR	ROLL
XY/YZ/ZX	YZ
DISCRETE SIGNAL MONITOR Group	
SEL 1/OFF/SEL 2	OFF
SIGNAL SEL 1	RDR ALT ENGAGED
SIGNAL SEL 2	RADAR ALT VALID
CONTINUITY Group	
A SELECT TENS	00
B SELECT TENS	00
A SELECT UNITS	0
B SELECT UNITS	0
MULTIMETER Group	
DISPLAY	BRIGHT
METER SOURCE	SELF TEST
ILCA DRIVE Group	
PITCH	0
ROLL	0
YAW	0
HYDR VALVE	CLOSE
DRIVE/FDBK MONITOR SELECT	RTN
PITCH/ROLL/YAW MONITOR SELECT	PITCH
ACTUATOR DRIVE Group	
CCDA	OFF
DASH	OFF
LCT	OFF
CCDA CLUTCH	OFF
CCDA BRAKE	OFF
FEEDBACK MONITOR	CCDA
Individual Switches	
CPT MONITOR	LATERAL
AFCS ANN	OFF
SELF TEST	OFF
HDG SEL	OFF
DASH PRE-ENGAGE	OFF

(4) Turn the SELF TEST switch clockwise through all positions. Verify that all operating voltages are present and within the tolerances listed below and that all indicators are operational.

SELF TEST Switch Position	Output Voltage Range
OFF	SELF TEST OFF
LAMPS	ALL LIGHTS COME ON
DISPLAY	+ .8.8.8.8
DMM +5 VDC	+4.92 to +5.08 vdc digital
DMM +15 VDC	+14.81 to +15.19 vdc digital
DMM -15 VDC	-14.81 to -15.19 vdc digital
+3.6 VAC	+3.26 to +3.94 vac analog
-3.6 VAC	-3.26 to -3.94 vac analog
13 VAC	+11.72 to +14.28 vac analog
26 VAC	+23.20 to +28.80 vac analog
-7 VDC	-6.83 to -7.17 vdc analog
+7 VDC	+6.83 to +7.17 vdc analog
+12 VDC	+10.85 to +13.15 vdc analog
-15 VDC	-14.81 to -15.19 vdc analog
+15 VDC	+14.81 to +15.19 vdc analog
+28 VDC	+23.00 to +29.00 vdc analog

(5) If all self test indications areas required, begin the test of the AFCS components. Refer to TM 55-1520-240-23.

c. Shutdown Procedure.

- (1) Set the 28 VDC and 115 VAC POWER switches to OFF.
- (2) Shut down helicopter power.
- (3) Disconnect the cables, first from the helicopter and then from test set.
- (4) Connect helicopter J1 (031P8) and J3 (031P3) for AFCS #1 or J1 (031P10) and J3 (031P4) for AFCS #2 to AFCS computer.

SECTION III PREVENTIVE MAINTENANCE CHECKS AND SERVICES

2-4. Preventive Maintenance.

Preventive maintenance is the systematic care, servicing, and inspection of equipment to prevent the occurrence of trouble, to reduce out-of-service time, and ensure that the equipment is serviceable.

a. Systematic Care. The process given in para 2-5 covers routine systematic care and cleaning essential to proper upkeep and operation of the test set.

b. Preventive Maintenance Checks and Services. The preventive maintenance checks and services chart (para 2-5) outlines functions to be performed at specific intervals. These checks and services are performed to maintain the test set in serviceable condition; that is, in good general (physical) condition and in good operating condition. Certain checks are performed before, during, and after operation of the test set.

(1) Before you operate. Perform your *before* (B) checks and services.

(2) While you operate. Perform your *during* (D) checks. If the test set fails to operate, troubleshoot using the specified test equipment and the procedures in Chapter 4. Report deficiencies using proper forms. (Refer to TM 38-750.)

(3) After you operate. Perform your *after* (A) checks.

2-5. Operator Preventive Maintenance Checks and Services Chart.

NOTE

Within designated interval, these checks are to be performed in the order listed.

Item No.	Interval			Item to be Inspected	Procedures Check for and have repaired or adjusted as necessary	Equipment Is Not Ready/ Available If:
	B	D	A			
1	●			Case and cover	Clean exterior, using cloth. For stubborn dirt, use cloth damp with cleaning solvent.	
2			●	Nameplate	Condition, legibility.	
3	●			Latches	Condition, secure mounting.	
4	●			Handles	Condition, secure mounting, positive closure.	
5	●			Air valve	Cleanliness, operation.	

Item No.	Interval			Item to be Inspected	Procedures Check for and have repaired or adjusted as necessary	Equipment Is Not Ready/ Available If:
	B	D	A			
6	●			Cables	Insulation for condition. Repair damaged insulation using tape. Connector shells for condition. Replace cable if shell is damaged. Contacts for cleanliness. Clean as required.	
7	●			Front	Clean, using paint brush. For stubborn dirt, use cloth damp with cleaning solvent.	
8	●			Receptacles	Straightness of pins. Straighten bent pins.	Damage exceeds damage to pins.
9	●			Control knobs	Tight on shaft. Tighten setscrew if necessary, and check alignment of each switch position with panel markings.	
10	●			Indicator lights	Condition of lenses. Replace if damaged.	
11	●			Meter	Condition of cover glass.	Glass is cracked or broken.
12	●			DMM	Condition and cleanliness of meter cover. Replace if cracked.	
13	●			Elapsed time indicator	Appropriate change since last check.	
14	●			Rotary switches	Secure mounting, positive detent. Tighten loose switches.	Detent is not positive.
15	●			Receptacles toggle switches, indicators, circuit breakers	Secure mounting.	

Item No.	Interval			Item to be Inspected	Procedures Check for and have repaired or adjusted as necessary	Equipment Is Not Ready/ Available If:
	B	D	A			

POWER ON CHECKS

16		●		Test set	Perform operational start and connection (para 2-4a, b).	Requirements of check are not met.
17		●		Test set	Perform self test (para 2-4b(4)).	Requirements of check are not met.
18			●	Test set	Perform shutdown (para 2-4c).	

CHAPTER 3

AVUM MAINTENANCE

SECTION I AVUM MAINTENANCE INSTRUCTIONS

3-1 General.

This chapter provides procedures for maintenance tasks authorized at Aviation Unit Maintenance (AVUM) level. Except for the tasks covered in this chapter, no special maintenance instructions are required. Repair at this level is limited to lamp and lens replacement and cables replacement or repair.

3-2. Servicing.

a. There are no servicing requirements except for those tasks identified in the preventive maintenance checks and service chart (para 3-9).

b. The following tools are required to perform AVUM maintenance on the test set.

- (1) Tool kit electronic equipment TK-101/G NSN 5180-00-064-5178.
- (2) Crimping tool assembly NSN 5120-00-075-2544.

3-3. Cleaning.

a. Inspect the exterior of the equipment. The exterior surface shall be free of dust, dirt, grease, and fungus. Remove dust and loose dirt with a clean soft cloth.

WARNING

Dry cleaning solvent is combustible and toxic. It can irritate skin and cause burns. Use only with adequate ventilation, away from open flame. In case of contact, immediately flush skin or eyes with water for at least 15 minutes. Get medical attention for eyes.

b. Remove grease, fungus, and ground-in dirt from the equipment using a cloth damp with solvent (item 1, table 3-1).

c. Clean the front panel, multimeter glass, indicator lenses, and control knobs and switches. Use a clean, soft cloth. If necessary, dampen the cloth (item 2, table 3-1) with water. Use mild soap (item 3, table 3-1) for more effective cleaning.

3-4. Touch-Up Painting.

a. Case or Cover. Refer to the applicable cleaning and refinishing practices in TM 43-0139.

(1) Finish.

(a) Remove corrosion from case or cover by sanding with abrasive cloth (item 4, table 3-1).

Table 3-1. Consumable Materials (AVUM)

ITEM NUMBER	NOMENCLATURE	MILITARY SPECIFICATION
1	Dry Cleaning Solvent	P-D-680
2	Cloth, Cleaning	CCC-C-46A
3	Soap, toilet, liquid and paste	P-S-624
4	Cloth, abrasive, Type H, Class I, 220 grit or finer	GGG-C-520
5	Naphtha, Aliphatic, Type II	TT-N-95
6	Enamel, Yellow Gloss, Color No. 13538	TT-E-529
7	Primer	TT-P-1757
8	Enamel, Black Gloss, Color No. 17038	TT-E-529

WARNING

Naphtha is combustible and toxic. It can irritate skin and cause burns. Use only with adequate ventilation, away from open flame. In case of contact, immediately flush skin or eyes with water for at least 15 minutes. Get medical attention for eyes.

(b) Clean sanded surface using naphtha (item 5, table 3-1).

(c) Apply primer (item 7, table 3-1) to sanded areas of the case or cover.

(d) Apply yellow enamel (item 6, table 3-1) to areas with primer.

(2) Marking.

(a) Touch-up case or cover markings with gloss black enamel (item 8, table 3-1),

b. *Panel*: Touch-up of panel and marking is not recommended.

3-5. Replacement of Knobs.

- a. Loosen the two recessed socket head screws on the knob,
- b. Remove the knob from the shaft.
- c. Position the replacement knob on the shaft.
- d. Tighten the two screws on the shaft.

3-6. Replacement of Lamps.

- a. Unscrew the lens from the lamp holder.
- b. Lift out the defective lamp.
- c. Insert the replacement lamp.
- d. Position the lens on the lamp holder and hand tighten.

3-7. Cable/Connector Repair.

Refer to TM 55-1500-323-25. Cable wiring diagrams are in fig. 3-1 thru 3-3 of this manual.

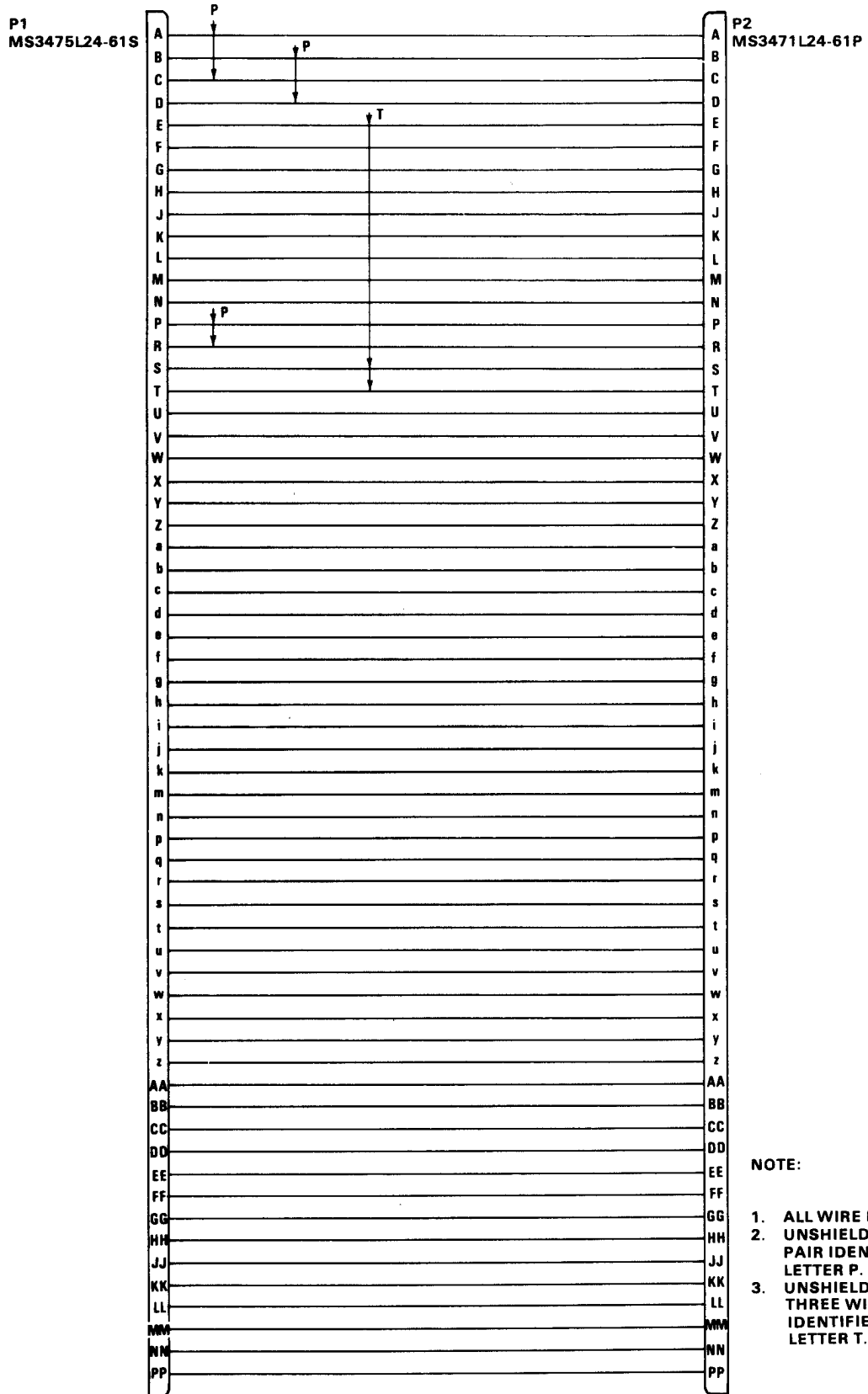

47D-TMDE-ALTS-24

Figure 3-1. Cable W1 Wiring Diagram

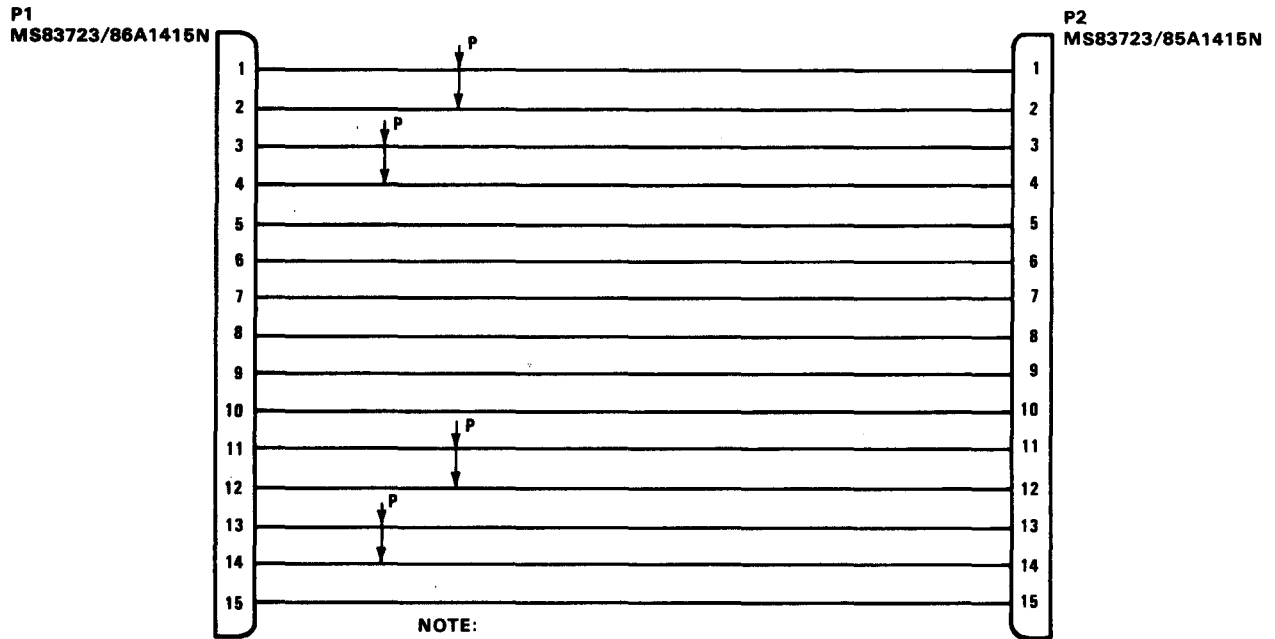

NOTE:

- 1. ALL WIRE NO. 20
- 2. UNSHIELDED TWISTED PAIR IDENTIFIED WITH LETTER P.
- 3. UNSHIELDED TWISTED THREE WIRES IDENTIFIED WITH LETTER T.

47D-TMDE-ALTS-25

Figure 3-2. Cable W2 Wiring Diagram

P1
MS3476L24-61SX

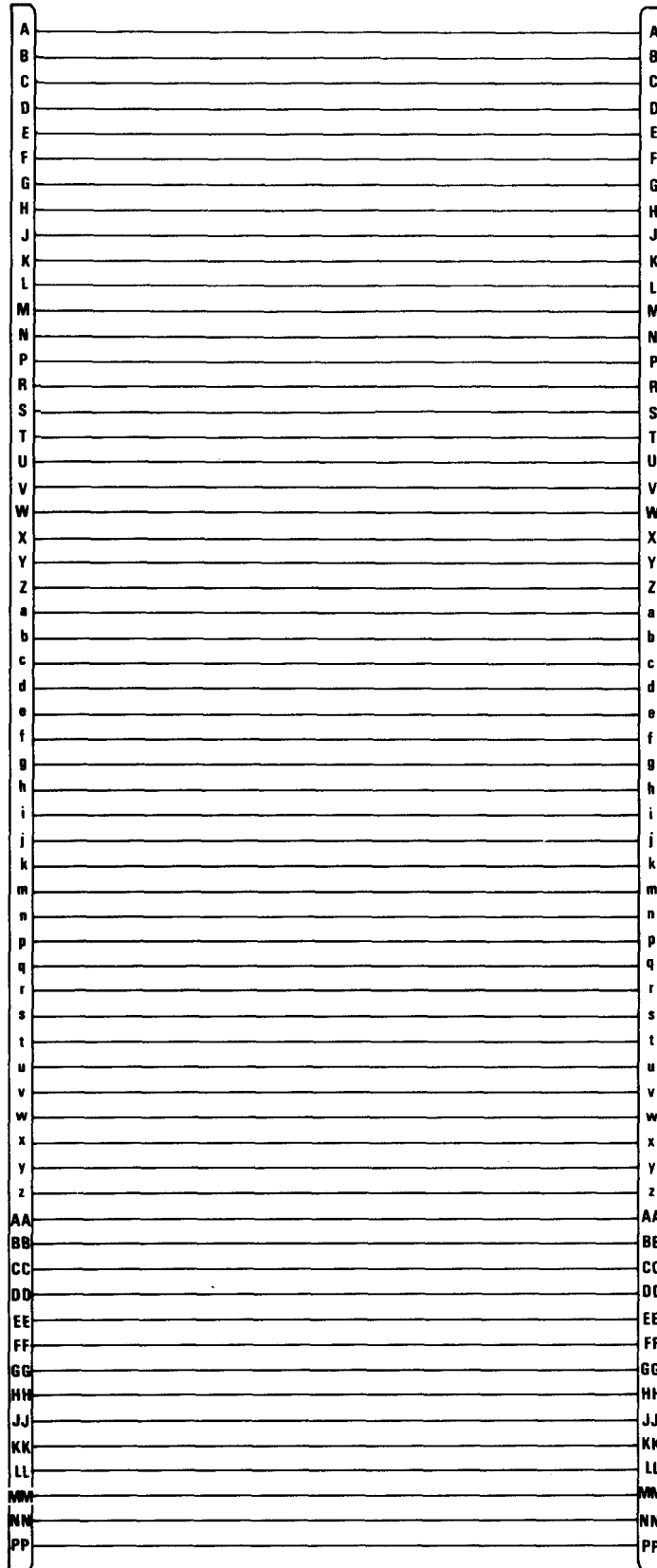

P2
MS3471L24-71PX

NOTE:

- 1. ALL WIRE NO. 20

47D-TMDE-ALTS-26

Figure 3-3. Cable W3 Wiring Diagram

SECTION II PREVENTIVE MAINTENANCE CHECKS AND SERVICES

3-8. Preventive Maintenance. preventive maintenance is the systematic care, servicing, and inspection of equipment to prevent the occurrence of trouble, to reduce out-of-service time, and to ensure that the equipment is serviceable.

a. Systematic Care. The procedures in para 3-9 cover routine systematic care and cleaning essential to proper unkeep and operation of the test set.

b. Preventive Maintenance Checks and Services. The preventive maintenance checks and services chart (para 3-9) outlines functions to be performed at specific intervals. These checks and services are performed to maintain the test set in serviceable condition; that is, in good general (physical) condition and in good operating condition. Before you operate, perform your *before* (B) checks and services.

3-9. AVUM Preventive Maintenance Checks and Services Chart.

NOTE

Within designated interval, these checks are to be performed in the order listed.

B-Before

Item No.	Interval B	Item to be Inspected	Procedures Check for and have repaired or adjusted as necessary	Equipment Is Not Ready/ Available If:
1	●	Case and cover	Clean exterior, using cloth. For stubborn dirt, use cloth damp with cleaning solvent.	
2	●	Nameplate	Condition, legibility.	
3	●	Latches	Condition, secure mounting.	
4	●	Handles	Condition, secure mounting, positive closure.	
5	●	Air valve	Cleanliness, operation.	
6	●	Cables	Insulation for condition. Repair damaged insulation using tape. Connector shells for condition. Replace cable if shell is damaged. Contacts for cleanliness. Clean as required.	

Item No.	Interval B	Item to be Inspected	Procedures Check for and have repaired or adjusted as necessary	Equipment Is Not Ready/ Available If:
7	●	Front	Clean, using paint brush. For stubborn dirt, use cloth damp with cleaning solvent.	
8	●	Receptacles	Straightness of pins. Straighten bent pins.	Damage exceeds damage to pins.
9	●	Control knobs	Tight on shaft. Tighten setscrew if necessary, and check alignment of each switch position with panel markings.	
10	●	Indicator lights	Condition of lenses. Re- place if damaged.	
11	●	Meter	Condition of cover glass.	Glass is cracked or broken.
12	●	DMM	Condition and cleanliness of meter cover. Replace if cracked.	
13	●	Elapsed time indicator	Appropriate change since last check.	
14	●	Rotary switches	Secure mounting, positive detent. Tighten loose switches.	Detent is not positive.
15	●	Receptacles toggle switches, indicators, circuit breakers	Secure mounting.	

Chapter 4

AVIM MAINTENANCE

SECTION I TROUBLESHOOTING

4-1. General Instructions

a. Troubleshooting procedures are provided in logic tree format. For each test paragraph, there is a troubleshooting paragraph with a similar heading. For each failure to meet a test requirement, there is a trouble symptom with a similar title. Use the schematic diagrams (FO-2 thru FO-4, fig. 1-2, 1-3, FO-6, FO-7, fig. 1-4 and FO-8) and the wiring diagrams (FO-22) as aids in troubleshooting.

b. On wiring diagrams, wire connections to the moving contacts of rotary wafer switches stop at the edge of the wafer. Physically, the moving contact is on the side of the wafer opposite the fixed contacts and is centered between two fixed contacts.

c. During troubleshooting, observe the following precautions and procedures.

(1) Voltage measurements. The test set includes transistor and microcircuits. When measuring voltages, use tape or plastic sleeving to insulate the test probe except for the extreme tip. A momentary short can ruin a solid state device. Use the digital multimeter specified in para 4-2.

(2) Resistance Measurements. Perform resistance and continuity checks with electrical power off.

(3) When the test set is disconnected from external test connections, all grounds in the test set are not at the same potential. Chassis ground is at receptacle pin J 1-f. Dc common is at TB1-7. Ac neutral is at TB1-3. Logic ground is at TB2-8. Analog ground is at TP2.

d For access to the rear of left-side front panel components, it may be necessary to remove the bottom plate of the chassis assembly. (Refer to para 4- 17.)

e. Use a card extender, where necessary, for making test measurements at card receptacles.

4-2. Test Equipment Required.

TEST EQUIPMENT	TEST SPECIFICATION
Variable Ac Power Supply 400 Hz (2 ea)	0 to 115 Vac 0.5% 0 to 6 Vac 0.5%
Oscilloscope Dual Trace	1 us to 500 ms/div 5 mV to 20V/div
Digital Multimeter	Ac: 50mV to 150V 0.5% Dc: 10mV to 50V 0.1%
Decade Resistor	1 ohm to 1.1 megohm 0.1%
Dc Power Supply 0-36 Volt (2 ea)	±.5%
Digital Multimeter	Ac: 50mV to 150V 0.5% Dc: 10mV to 50V 0.1%
Gyro Test Aid	Locally fabricated (fig. 4-3)
Card Extender	Receptacle M55302/27-06 (60 pin) to plug MS55302/26-02

NOTE

Page identification for foldout pages has been designated as FO-1, FO-2, etc. and the pages are placed in the back of the manual at time of printing. Upon receipt of this manual, insert foldout pages FO-9 through FO-21 after page 4-2.

SECTION II MAINTENANCE

4-14. General.

This section contains inspection, testing, component replacement, and cleaning instructions for the test set. No special tools are required. The test set requires no lubrication.

4-15. Panel Removal.

(See fig. 5-1.) Remove the cover and panel as follows:

- a. Press the air pressure relief valve (11) in the cover to equalize inside and outside air pressure.
- b. Unlatch seven latches and remove the cover from the case (10).
- c. Remove 23 screws (8) that secure the panel (9) to the case.
- d. Carefully lift the panel from case.

4-16. Inspection.

- a. Check all electrical connectors for bent or broken pins.
- b. Check wires for frayed or worn insulation,
- c. Check solder connections for corrosion or poor mechanical connection.
- d. Check rotary switches for proper alignment of switch positions with panel markings.

4-17. Disassembly.

(See fig. 5-3.) Test set components are accessible when the panel-chassis is removed from its case. Card cage (30) must be removed for access to ILCA DRIVE and ACTUATOR DRIVE switches. Bottom plate (17) must be removed for test-prod access to left-side panel components. Remove the card cage or bottom plate as follows:

- a. Remove two screws (21) securing retainer (22) to card cage (30).
- b. Remove the retainer and rubber from the card cage.

CAUTION

Do not handle or store circuit cards, except in a static-free environment, using static-free materials. Microcircuits can be damaged by static.

- c. Remove circuit cards A2 (25) and A3 (26).
- d. Remove two screws (35) and washers (36) securing the top of the card cage to the front panel.
- e. Remove four screws (21) securing the card cage to the support.
- f. Remove the card cage.
- g. Remove bottom plate (17) of the chassis assembly as follows: Remove 11 screws (16) and remove the bottom plate.

4-18. Cleaning.

a. Inspect the exterior of the equipment. The exterior should be free of dust, dirt, grease, and fungus. Remove dust and loose dirt with clean soft cloth.

Isopropyl alcohol is flammable and toxic. Avoid inhaling. Use only with adequate ventilation, Keep away from heat, sparks, or open flame. In case of contact, immediately flush skin or eyes with water for at least 15 minutes. Get medical attention for eyes.

b. Clean exposed switch contacts with isopropyl alcohol (item 1, table 4-1).

c. Use a vacuum cleaner and soft brush to remove dirt and dust from the test set chassis and the interior of the case.

Dry cleaning solvent, type I is combustible and toxic. It can irritate skin and cause burns. Use only with adequate ventilation, away from open flame. In case of contact, immediately flush skin or eyes with water for at least 15 minutes. Get medical attention for eyes.

d. Remove grease or oil with a cleaning cloth (item 2, table 4-1) moistened with dry cleaning solvent (item 3, table 4-1).

Trichloroethane MIL-T-81533 is toxic. It can irritate skin and cause burns. Avoid inhaling. Use only with adequate ventilation. Avoid contact with skin, eyes, or clothing. In case of contact, immediately flush skin or eyes with water for at least 15 minutes. Get medical attention for eyes.

Table 4-1. Consumable Materials (A VIM)

ITEM NUMBER	NOMENCLATURE	MILITARY SPECIFICATION
1	Isopropyl Alcohol	TT-I-735
2	Cloth Cleaning	CCC-C-46
3	Dry Cleaning Solvent	P-D-680
4	Trichloroethane	MIL-T-81533
5	Solder	QQ-S-571

e. Clean exterior of the case and the panel, with cleaning cloth moist with trichloroethane (item 4, table 4-1).

4-19. Circuit Card Replacement.

- a. Remove the panel from the case (para 4-15).
- b. (See fig. 5-3.) Remove the two screws (21) securing the retainer (22) to the card cage (30).
- c. Remove card (25 or 26) from receptacle by pulling the card straight out.
- d. Install replacement card in the receptacle, components towards panel.
- e. Align the cards and install the channel and rubber.
- f. Install the panel in the case (para 4-25).
- g. Perform the final test (para 4-26).

4-20. Replacement of Panel Component (CRC).

- a. (See fig. 5-3.) Remove the panel from the case (para 4-15).
- b. If needed for access, remove the card cage (para 4-17).
- c. Tag and disconnect the wires.
- a'. For a meter, remove the attaching hardware and remove the component.
- e. For a rotary switch, loosen the set screws and remove the knob.
- f. For an indicator, remove the lens and lamp.
- g. For a switch, indicator, circuit breaker, or relay, remove the nut and remove the component.
- h. Position the replacement part in the panel.
- i. For a switch, indicator, circuit breaker, or relay, install the nut.
- j. For an indicator, install the lamp and lens.
- k. For a rotary switch, position the knob and tighten two set screws.
- l. For a meter, install the attaching hardware.
- m. Connect the wires to the terminals. (See wiring diagram, FO-22.) Remove the tags.
- n. If it was removed, install the card cage (para 4-22).
- o. Install the panel in the case (para 4-25).
- p. Perform the final test (para 4-26).

4-21. Replacement of Power Supply or Transformer (CRC).

- a. (See fig. 5-2.) Remove the panel from the case (para 4-15).
- b. Tag and disconnect the wires.
- c. Remove the attaching hardware and remove the power supply or transformer.
- d. Position the replacement part on the assembly. Install the attaching hardware.
- e. Connect the wires. (See wiring diagram, FO-22.) Remove the tags.
- f. Perform the final test (para 4-26). Adjust the power supply (para 4-23).
- g. Install the panel in the case (para 4-25).

4-22. Assembly.

a. Card cage installation.

- (1) (See fig. 5-3.) Position the card cage (30) on the support.
- (2) Install the four screws (21) securing the card cage to the support.
- (3) Install two screws (36) and washers (35) that secure the top of the card cage (30) to the panel.
- (4) Install cards A2 (25) and A3 (26), components toward the panel.
- (5) Position the retainer (22) on the card cage.
- (6) Install two screws (21) securing retainer to card cage.

b. Bottom plate installation.

- (1) Position bottom plate (17) on the chassis assembly.
- (2) Install 11 screws (16).

4-23. Dc Power Supply Voltage Adjustments (CRC).

(See fig. 4-1.) The +15, -15, and +5 volt dc power supplies are adjusted by screwdriver adjustment on the power supplies.

a. Preliminary.

- (1) Remove the panel from the case (para 4-15).
- (2) Set both MASTER POWER switches to OFF. Check that the three circuit breakers are closed.



Always turn off power at the power source before connecting or disconnecting power to the test set. Damage to the test set can result,

- (3) Connect external power to the test set as follows: (See FO-8 for connector pin patterns.)

(a) J1-B	} 115 vac 400 hz	Line
(b) J1-D		Neutral
(c) J1-A	} 28 vdc +	
(d) J1-C		
(e) J1-E	} 28 vdc (cyclic +	
(f) J1-C		trim power) -

- (4) Set external power to ON.
- (5) Set both MASTER POWER switches to ON.
- (6) Set the METER SOURCE switch to SELF TEST.

b. Adjust power supply PS5 (+5 volt de).

- (1) Set the SELF TEST switch to +5 VDC (DMM).
- (2) Set the digital multimeter to the 20 volt dc range. Connect the test leads of the multimeter to the HI and LO jacks of the test set.

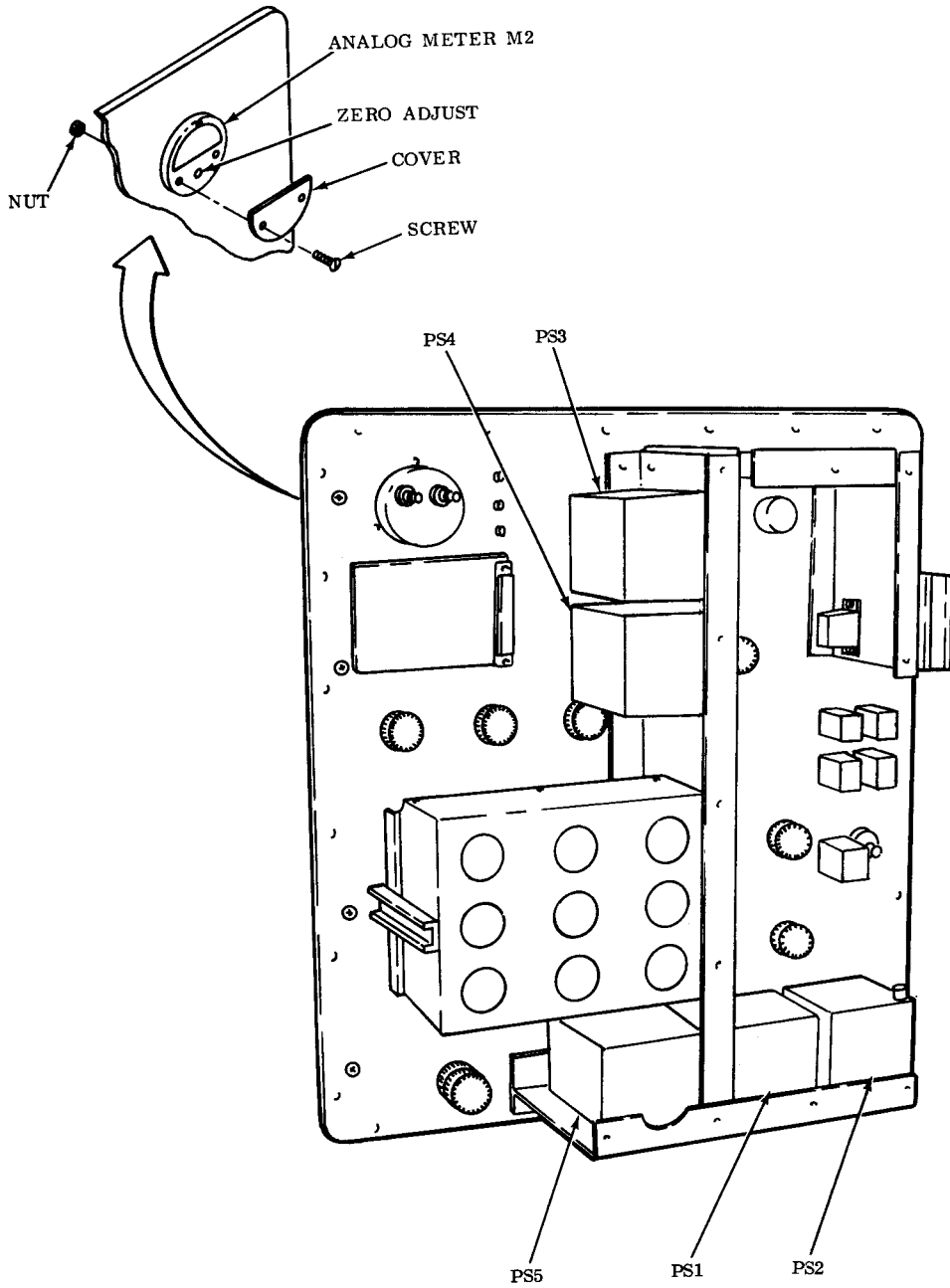

47D-TMDE-ALTS-35

Figure 4-1. DC Power Supply and Analog Meter Adjustments

(3) Turn the screwdriver adjustment on power supply PS5 for +5.00 volts on the digital multimeter. The DMM shall indicate +4.92 to +5.08.

c. Adjust power supply PS3 (+15 volt dc).

(1) Set the SELF TEST switch to +15 VDC (DMM).

(2) Set the digital multimeter to the 20 volt dc range. Connect the test leads of the multimeter to the HI and LO jacks of the test set.

(3) Turn the screwdriver adjustment on power supply PS3 for +15.00 volts on the digital multimeter. The DMM shall indicate +14.81 to +15.19.

d. Adjust power supply PS4 (-15-volt dc).

(1) Set the SELF TEST switch to -15 VDC (DMM).

(2) Set the digital multimeter to the 20-volt dc range. Connect the test leads of the multimeter to the HI and LO jacks of the test set.

(3) Turn the screwdriver adjustment on power supply PS4 for -15.00 volts on the digital multimeter. The DMM shall indicate -14.81 to -15.19.

e. Adjust power supply PS2 (-15 volt dc).

(1) Set the SELF TEST switch to -15 VDC.

(2) Set the digital multimeter to 20-volt dc range. Connect the test leads of the multimeter to the HI and LO jacks of the test set.

(3) Turn the screwdriver adjustment on power supply PS2 for -15 volts on the digital multimeter. The DMM shall indicate -14.81 to -15.19.

f. Adjust power supply PS1 (+15-volt dc).

(1) Set the SELF TEST switch to +15 VDC.

(2) Set the digital multimeter to the 20-volt dc range. Connect the test leads of the multimeter to the HI and LO jacks of the test set.

(3) Turn the screwdriver adjustment on power supply PS1 for +15 on the digital multimeter. The DMM shall indicate + 14.81 to +15.19.

g. Shutdown.

(1) Set both MASTER POWER switches to OFF.

(2) Set external power to OFF. Disconnect the power connections.

(3) Install the panel in its case (para 4-25).

4-24. Analog Meter Zero Adjustment.

(See fig. 4-1.) Zero adjust the analog meter as follows:

a. Remove the panel from the case (para 4-15).

b. Remove two screws and nuts and remove the cover from the meter.

c. With the panel horizontal, turn the zero adjust screw until the meter pointer is centered on 0.

d. Position the cover on the meter and install two screws and nuts.

e. Install the panel in its case (para 4-25).

4-25. Panel Installation.

- a. Install the panel in case (fig. 5-1).
- b. Secure the panel to the case with 23 screws.
- c. Install cover and engage seven latches.

4-26. Final Test (CRC).

These tests ensure the performance of all circuits of the test set. They are, however, organized so that the performance of an individual circuit can be evaluated. The troubleshooting procedures in Section I are correlated to this test by test paragraph reference as well as by malfunction description. Tests are performed in the order in which they are presented.

4-27. Test Equipment and Accessories Rewired. The following test equipment and accessories are required:

- a. Test equipment.

TEST EQUIPMENT	SPECIFICATIONS
Variable AC Power Supply 400 Hz (2 ea)	0 to 115 Vac, 0.5% 0 to 6Vac, 0.1 %
Variable DC Power Supply	0 to 20Vdc. Dual outputs & controls
Digital Multimeter (2 ea)	AC: 50mV to 15V, 0.5% Dc: 10mV to 50V, 0.1%
Decade Resistor	1 ohm to 1.1 Megohm Accuracy 0.1%
Oscilloscope, Dual Trace	1us to 500ms/div 5mV to 20V/div
Gyro Test Aid	Locally fabricated (fig. 4-3)

- b. The following test accessories are required.

ITEM	DESCRIPTION	QTY
Test lead	Banana jack with 18 inches of No. 16 wire attached to miniature female pin	10 ea.

4-28. Preliminary Procedures. Prior to beginning the tests, perform the following preliminary procedures.

- a. Set both MASTER POWER switches to OFF. Check that the three circuit breakers are closed.



Always turn off power at the power source before connecting or disconnecting test set cables between power source and test set. Otherwise injury to personnel or damage to equipment can result.

TM 55-4920-429-13

b. Connect external power to the test set as follows: (See FO-8 for connector pin patterns.)

(1) J1-B	115Vac 400Hz	Line
(2) J1-D		Neutral
(3) J1-A	28Vdc	+
(4) J1-C		
(5) J1-E	28VDC Cyclic	+
(6) J1-C		Trim Power

c. Unless otherwise indicated in the specific test instruction, set the controls and switches to their initial positions as listed in table 2-2.

d. Turn on external power to the test set. At the MASTER power panel, the CYCLIC TRIM 28VDC indicator shall come on.

e. Set the 115VAC switch to ON. The 115VAC indicator shall come on.

f. Set the 28VDC switch to ON. The 28VDC indicator shall come on.

g. Set both MASTER POWER switches to OFF.

4-29. Self Test and Power Supply Tests. The following tests check operation of the self test circuits. In addition, they ensure correct output of internal power supplies.

a. *Multimeter Zero Test.* Set both MASTER POWER switches to ON. Set the METER SOURCE switch to OFF. The VDC indicator shall come on. The digital multimeter (dmm) shall read +0.005 to -0.005. The analog meter shall read 0 ± 1 scale division.

b. *Continuity Test.* Set the METER SOURCE switch to CONTINUITY. The K-OHMS indicator shall come on and the VDC indicator shall go out. The dmm shall read +9.77 to +10.23.

c. *Lamp Test.*

(1) Set the SELF TEST switch to LAMPS. The SIGNAL MONITOR, STATUS A, and STATUS B indicators shall come on. The MULTIMETER, VDC, VAC, and K-OHMS indicators shall come on.

(2) Cycle the DISPLAY switch between BRIGHT and DIM. Lighted indicators and the dmm shall cycle between bright and dim.

d. *DMM Display Test.*

Set the SELF TEST switch to DISPLAY. The dmm shall read +.8.8.8.8. All display segments shall be lit.

e. *Power Supply Tests.*

(1) Set the METER SOURCE switch to SELF TEST.

(2) Connect the digital multimeter across the HI (+) and LO binding posts.

(3) Set the SELF TEST switch to each of the settings listed below. The readings on the dmm and the external multimeter shall be as listed below. The corresponding indicator, VAC or VDC, shall come on.

SWITCH POSITION	DMM READING	DIGITAL MULTIMETER READING (8800A)
DMM +5 VDC	+4.92 To +5.08	+4.990 To +5.010
DMM +15 VDC	+14.81 To +15.19	+14.970 To +15.030
DMM -15 VDC	-14.81 To -15.190	-14.970 To -15.030
DMM +3.6 VAC	+3.26 To +3.94	3.42 To 3.78
DMM -3.6 VAC	-3.26 To -3.94	3.42 To 3.78
DMM 13 VAC	+11.72 To +14.28	12.20 To 13.80
DMM 26 VAC	+23.20 To +28.80	24.40 To 27.60
DMM -7 VDC	-6.83 To -7.17	-6.93 To -7.07
DMM +7 VDC	+6.83 To +7.17	+6.93 To +7.07
DMM +12 VDC	+10.85 To +13.15	+11.00 To +13.00
DMM -15 VDC	-14.81 To -15.19	-14.97 To -15.03
DMM +15 VDC	+14.81 To +15.19	+14.97 To +15.03
DMM +28 VDC	+23.00 To +29.00	+23.00 To +29.00

(4) Set SELF TEST and METER SOURCE switches to OFF.

4-30. Multimeter Tests. This test ensures the accuracy of the dmm and the analog meter and associated circuits.

a. VDC Range Tests.

(1) Connect the digital multimeter, set to measure dc volts, across the HI (+) and LO binding posts.

(2) Set the FDBK MON switch to LCT.

(3) Set the METER SOURCE switch to ACTUATOR DRIVE.

(4) Connect the variable dc power supply to receptacle pins J3-x (+) and J3-C. Adjust the power supply to the voltages listed below. The VDC indicator shall come on. The K-OHM and VAC indicators shall be out. (See FO-8 for connector pin patterns.)

TEST VOLTAGE (J3-x)	DMM	ANALOG METER
+1.000	+0.098 to .1020	N/A
-1.000	-0.991 to -1.009	-0.92 to -1.08
+10.00	+9.88 to +10.12	+9.2 to +10.8
+25.00	+24.50 to +25.5	N/A

TM 55-4920-429-13

(5) Disconnect dc voltage from receptacle J3.

b. VAC Range Tests.

(1) Connect the digital multimeter, set to measure ac volts, across the HI (line) and LO binding posts.

(2) Set the FDBK MON switch to CCDA.

(3) Set the METER SOURCE switch to ACTUATOR DRIVE.

(4) Connect the variable ac power supply to receptacle pins J3-e (line) and J3-f. The readings on the dmm and the analog meter shall be as listed below. Applied voltage must be in phase with the 115-volt ac source (J1-B). The VAC indicator shall be on. The K-OHM and VDC indicators shall be out. **(See FO-8 for connector pin patterns.)**

TEST VOLTAGE	DMM	ANALOG METER
.0000	-.0018 to +.0018	0±0.2
+10.00	+9.66 to +10.34	—
-10.00	-9.66 to -10.34	—

(5) Disconnect external ac power supply and digital multimeter.

c. K-OHMS Range Test.

(1) Set the METER SOURCE switch to CONTINUITY.

(2) Set A SELECT TENS CONTINUITY switch to 00. Set A SELECT UNITS CONTINUITY switch to 9.

(3) Set B SELECT TENS CONTINUITY switch to 00. Set B SELECT UNITS CONTINUITY switch to 8.

(4) Connect the decade resistor to pins J1-H and J1-J. Adjust the decade resistor to the resistance listed below. For each resistance setting, the reading on the dmm shall be as listed below. The K-OHM indicator shall be on. The VAC and VDC indicators shall be out. **(See FO-8 for connector pin patterns.)**

DECADE RESISTOR SETTING (OHMS)	DMM
0	-0.002 to +0.002
1,000	0.980 to 1.020
10,000	9.80 to 10.20
100,000	98.0 to 102.0
1,000,000	980 to 1020

(5) Disconnect the decade resistor from receptacle J1. Set the CONTINUITY switches to 00 or 0.

d. Meter Hyteresis Test.

(1) Set the FDBK MON switch to LCT. Set the METER SOURCE switch to ACTUATOR DRIVE.

(2) Connect the variable the power supply to receptacle pins J3-x (+) and J3-C. Connect the digital multimeter, set to measure dc volts, across the HI (+) and LO binding posts. (See FO-8 for connector pin patterns.)

(3) Adjust the dc power supply to each of the test voltages listed below. Pay particular attention to the lead digit and the location of the decimal point. X indicates that the value of a digit is not significant.

TEST VOLTAGE (DC)	DMM
0	.XXXX
+19	+1X.XX
+25	+2X.X
+19	+1X.X
+17	+1X.XX

(4) Disconnect the dc power supply from receptacle 3. Disconnect the digital multimeter from the binding posts.

4-31. Discrete Signal Monitor Circuit Test. The following test ensures the correct operation of the SEL 1/SEL 2, SIGNAL SEL 1, and SIGNAL SEL 2 switches, STATUS A and B lights, and associated circuits.

a. Set the METER SOURCE switch to DISCRETE MON. Set the SEL 1/SEL 2 switch to SEL 1. Set the SIGNAL SEL 1 switch to RADAR ALT ENGAGED.

b. Test the circuits of the SIGNAL SEL 1 switch as follows: Connect input signals from the dc power supply to receptacle pins as listed below. Connect the digital multimeter across the output of the dc power supply. STATUS lights and dmm indications shall be as listed. The VDC indicator shall be on. The VAC and K-OHM indicators shall be out. (See FO-8 for connector pin patterns.)

c. Disconnect the dc power Supply. Set the SEL 1/SEL 2 switch to SEL 2.

SIGNAL SELECT 1 SWITCH POSITION	INPUT SIGNAL CONDITION	RECEPTACLE PINS	STATUS ALT	STATUS BLT	DMM
RADAR ALT ENGAGED	11 Vdc	J3-j (+)	ON	OFF	+10.85 To 11.15
		J3-AA			
	9 Vdc	Same	OFF	OFF	+ 8.87 To 9.13
	3 Vdc	Same	OFF	OFF	+ 2.93 To 3.07
	Open Ckt	—	OFF	ON	N/A
BARO ALT ENGAGED	11 Vdc	J3-i(+)	ON	OFF	+10.85 To 11.15
		J3-AA			

SIGNAL SELECT 1 SWITCH POSITION	INPUT SIGNAL CONDITION	RECEPTACLE PINS	STATUS ALT	STATUS BLT	DMM
HDG ENGAGE ON	9 Vdc	Same	OFF	OFF	+ 8.87 To 9.13
	3 Vdc	Same	OFF	OFF	+ 2.93 To 3.07
	Open Ckt	—	OFF	ON	N/A
	11 Vdc	J3-h(+)	ON	OFF	+10.85 To 11.15 ■
		J3-AA			
L LDG GEAR ON GND	9 Vdc	Same	OFF	OFF	+ 8.87 To 9.13
	3 Vdc	Same	OFF	OFF	+ 2.93 To 3.07
	Open Ckt	—	OFF	ON	N/A
	11 Vdc	J3-b(+)	ON	OFF	+10.85 To 11.15 ■
		J3-AA			
R LDG GEAR ON GND	9 Vdc	Same	OFF	OFF	+ 8.87 To 9.13
	3 Vdc	Same	OFF	OFF	+ 2.93 To 3.07
	Open Ckt	—	OFF	ON	N/A
	NOTE : Next switch position is out of sequence.				
	11 Vdc	J3-G(+)	ON	OFF	+10.85 To 11.15 ■
CYCLIC MAG BRAKE ON		J3-AA			
	9 Vdc	Same	OFF	OFF	+ 8.87 To 9.13
	3 Vdc	Same	OFF	OFF	+ 2.93 To 3.07
	Open Ckt	Same	OFF	ON	N/A
	23 Vdc	J1-a(+)	ON	OFF	N/A
C LTV MAG BRK ON		J1-C			
	20 Vdc	Same	OFF	OFF	N/A
	5 Vdc	Same	OFF	OFF	N/A
	Open Ckt	Same	OFF	ON	N/A
	23 Vdc	J1-w(+)	ON	OFF	N/A
AFCS ENGAGE ON		J1-C			
	20	Same	OFF	OFF	N/A
	5	Same	OFF	OFF	N/A
	Open Ckt	Same	OFF	ON	N/A
	23 Vdc	J3-k(+)	ON	OFF	N/A
SWIVEL LOCKED		J1-C			
	20	Same	OFF	OFF	N/A
	5	Same	OFF	OFF	N/A
	Open Ckt	Same	OFF	ON	N/A
	23 Vdc	J3-d(+)	ON	OFF	N/A
		J1-C			
	20 Vdc	Same	OFF	OFF	N/A
	5 Vdc	Same	OFF	OFF	N/A
	Open Ckt	Same	OFF	ON	N/A

d. Test the circuits of SIGNAL SEL 2 switch as follows: When ac or dc input signals are required, connect the power supply across the receptacle pins listed below. Connect the digital multimeter across the output of the power supply. STATUS lights shall be as listed below. (See FO-8 for connector pin patterns.)

SIGNAL SELECT 2 WITCH POSITION	INPUT SIGNAL CONDITION	RECEPTACLE PINS	STATUS ALT	STATUS BLT
RADAR ALT VALID	4 Vdc	J3-LL(+)	ON	OFF
		J3-AA		
	3 Vdc	Same	OFF	OFF
	2 Vdc	Same	OFF	OFF
RADAR ALT SELF TEST GO	Open Ckt	Same	OFF	ON
	4 Vdc	J3-z(+) & J3-AA	ON	OFF
	3 Vdc	Same	OFF	OFF
	2 Vdc	Same	OFF	OFF
L ROLL BEEP TRIM ON	Open Ckt	Same	OFF	ON
	12 Vac	J3-FF (line)	ON	OFF
		J3-AA		
	10 Vac	Same	OFF	OFF
R ROLL BEEP TRIM ON	2 Vac	Same	OFF	OFF
	Open Ckt	Same	OFF	ON
	12 Vac	J3-GG (line)	ON	OFF
		J3-AA		
VERT GYRO VALID	10 Vac	Same	OFF	OFF
	2 Vac	Same	OFF	OFF
	Open Ckt	Same	OFF	ON
	1.5 Vdc	J3-R(+) & J3-AA	ON	OFF
HYD PRESSURE FULL	Open Ckt	Same	OFF	ON
	Shorted to gnd	Same	ON	OFF
	1.5 Vdc	J3-a(+)	OFF	OFF
BIT ENABLE STOP		J1-C		
	Open Ckt	Same	OFF	ON
	Shorted to gnd (return)	Same	ON	OFF
	1.5 Vdc	J3-B(+) & J3-AA	OFF	OFF
	Open Ckt	Same	OFF	ON
	Shorted to gnd	Same	ON	OFF

e. Disconnect the dc power supply.

TM 55-4920-429-13

4-32. ILCA DRIVE. These tests insure that valve command, SUM 1/SUM 2, and feedback circuits for pitch, roll, and yaw ILCA function as required. **(See FO-8 for connector pin patterns.)**

- a. Connect the digital multimeter, set to read dc volts, across pins J3-A(+) and J1-C. Set the HYDR VALVE switch to OPEN. The digital multimeter shall read +23 to +29 volts.
- b. Set the HYDR VALVE switch to CLOSE. The digital multimeter shall read -1 to +1 volt.
- c. Disconnect the digital multimeter.
- d. Set the METER SOURCE switch to ILCA DRIVE.
- e. Connect a variable ac power supply to the receptacle pins listed below. Connect a digital multimeter, set to measure ac volts, across the output of the power supply. Adjust the power supply to 10 “ volts. The dmm shall read +9.65 to +10.35 for each test connection and position of the MONITOR SELECT switch.

LINE	AC SUPPLY	NEUTRAL	MONITOR PITCH/ROLL/YAW	SELECT FDBK
J1-N		J1-M	PITCH	SUM 2
J1-L		J1-M	PITCH	SUM 1
J1-m		J1-k	ROLL	SUM 2
J1-j		J1-k	ROLL	SUM 1
J1-LL		J1-KK	YAW	SUM 2
J1-BB		J1-KK	YAW	SUM 1

- f. Disconnect the ac power supply and digital multimeter.
- g. Test the pitch servo loop as follows: (See fig. 4-2.)
 - (1) Connect a decade resistor, set to 2,000 ohms, across pins J1-JJ and J1-PP.
 - (2) Set the MONITOR SELECT switch to PITCH.
 - (3) Connect a jumper across pins J1-W and J1-X. For each combination of switch settings, the dmm shall read as listed below.

ILCA DRIVE PITCH SWITCH	MONITOR SELECT DRIVE/FDBK	DMM READING
0	SELF FDBK	-0.500 To +0.500
MAX EXT	HI DRIVE	+6.00 To +14.00
85% EXT	HI DRIVE	+4.162 To +5.297
85% EXT	RTN DRIVE	+0.237 To +0.302
0	HI DRIVE	-0.500 To +0.500
85% RETR	HI DRIVE	-4.162 To -5.297
85% RETR	RTN DRIVE	-0.237 To -0.302
MAX RETR	HI DRIVE	-6.00 To -14.00

PITCH SERVO LOOP TEST

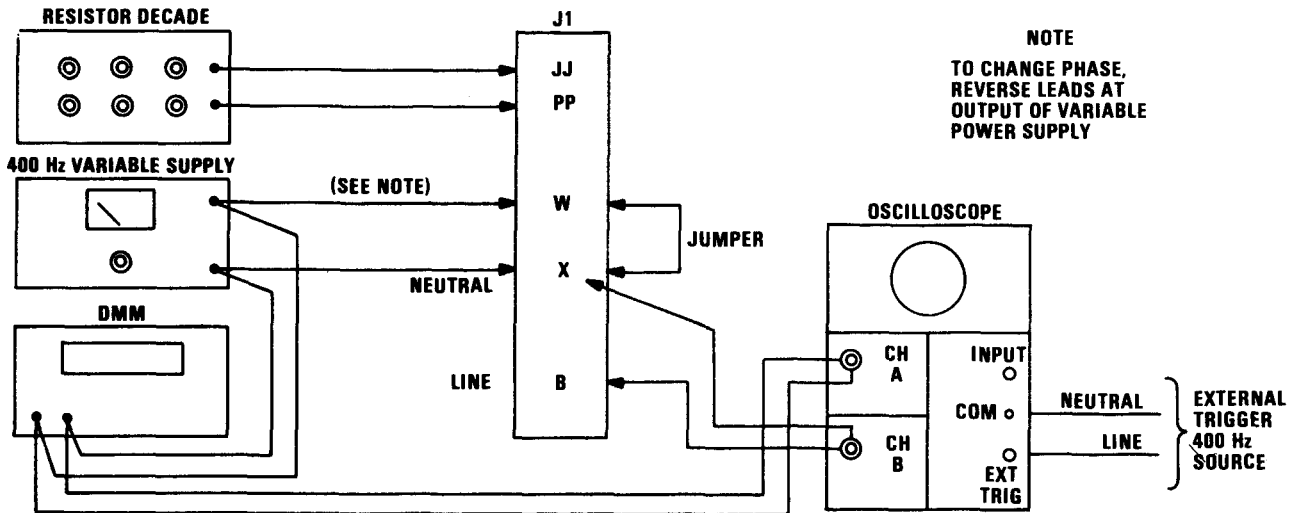

ROLL SERVO LOOP TEST

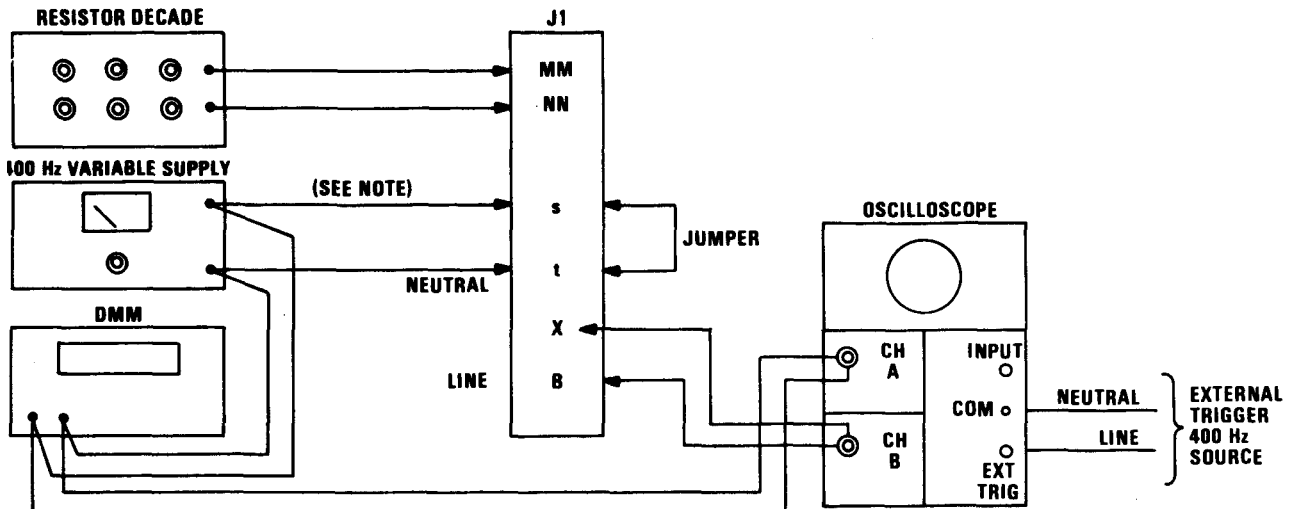

YAW SERVO LOOP TEST

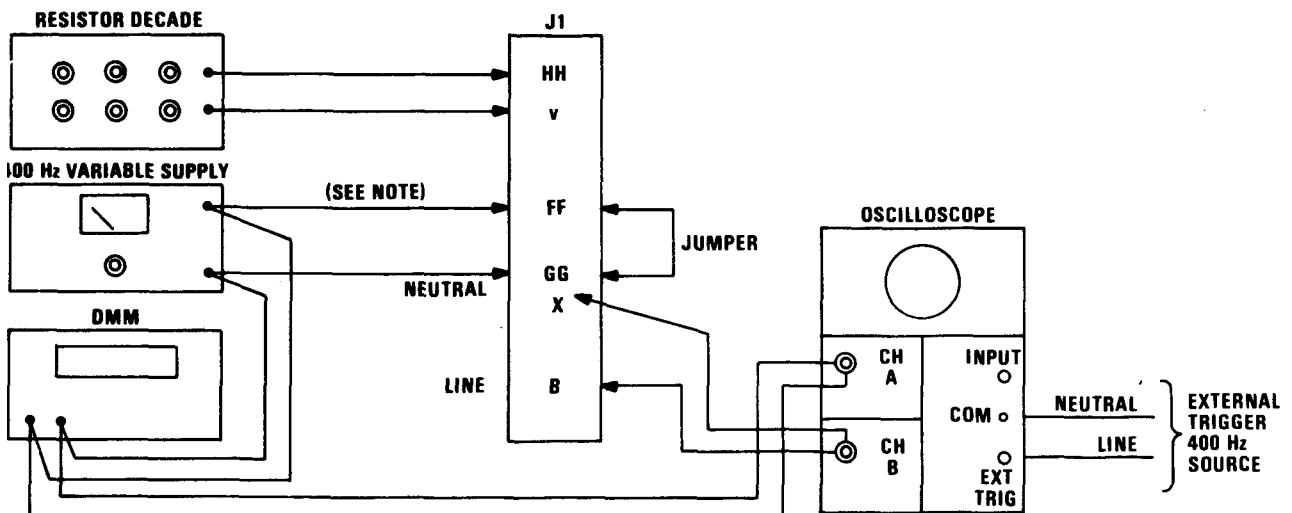

47D-TMDE-ALTS-42

Figure 4-2. ILCA Drive Test Setup

- (4) Remove the jumper wire.

NOTE

- When a test includes a requirement that an ac voltage be in-phase or out-of-phase, oscilloscope channel A must be connected across the digital multimeter. Oscilloscope channel B must be connected to the ac source and the oscilloscope externally triggered from the ac source.
- The minus sign (-) before an ac voltage indicates out-of-phase.

(5) Connect a variable ac power supply to receptacle pins J1-W and J1-X. Voltage shall be 180° out of phase with respect to the 115-volt ac source at J1-B.

(a) Set the PITCH switch to MAX EXT.

(b) Adjust the power supply for .0000 on the dmm.

(c) Connect an external digital multimeter, set to measure ac volts to the output of the ac power supply. The voltage shall be 0.8602 to 1.0940 vat.

(6) Connect a variable ac power supply to receptacle pin J1-W and J1-X. Voltage must be in phase with respect to the 115 volt ac source at J1-B.

(a) Set the PITCH switch to MAX RETR.

(b) Adjust the power supply for .0000 on the dmm.

(c) Connect an external digital multimeter, set to measure ac volts, to the output of the ac power supply. The voltage shall be 0.8602 to 1.0940 vat.

(7) Disconnect the external power supply and decade resistor.

h. Test the roll servo loop as follows: (See fig. 4-2.)

(1) Connect a decade resistor, set to 2,000 ohms, across receptacle pins J1-NN and J1-MM.

(2) Set the MONITOR SELECT switch to ROLL.

(3) Connect a jumper across pins J1-s and J1-t. For each combination of switch settings, the dmm shall read as listed below.

ROLL SWITCH	MONITOR SELECT DRIVE/FDBK	DMM READING
0	SELF FDBK	-0.500 To +0.500
MAX EXT	HI DRIVE	+8.00 To +14.00
85% EXT	HI DRIVE	+5.41 To +6.89
85% EXT	RTN DRIVE	+0.308 To +0.392
0	HI DRIVE	-0.500 To +0.500
85% RETR	HI DRIVE	-5.41 To -6.89
85% RETR	RTN DRIVE	-0.308 To -0.392
MAX RETR	HI DRIVE	-8.00 To -14.00

(4) Remove the jumper wire.

NOTE

- When a test includes a requirement that an ac voltage be in-phase or out-of-phase, oscilloscope channel A must be connected across the digital multimeter. Oscilloscope channel B must be connected to the ac source and the oscilloscope externally triggered from the ac source.
- The minus sign (-) before an ac voltage indicates out-of-phase.

(5) Connect a variable ac power supply to receptacle pins J1-s and J1-t. Voltage shall be 180° out of phase with respect to the 115 volt ac source at J 1-B.

(a) Set ROLL switch to MAX EXT.

(b) Adjust the power supply for .0000 on the dmm.

(c) Connect an external digital multimeter, set to measure ac volts, to the output of the ac power supply. The voltage shall be 1.113 to 1.417 volts ac.

(6) Connect a variable ac power supply receptacle pins J1-s and J1-t. Applied voltage shall be in phase with respect to the 115 volt ac source at J1-B.

(a) Set the ROLL switch to MAX RETR.

(b) Adjust the power supply for .0000 on the dmm.

(c) Connect an external digital multimeter, set to measure ac volts, to the output of the ac power supply. The voltage shall be 1.113 to 1.417 volt ac.

(7) Disconnect external voltage source and decade resistor.

i. Test the yaw servo loop as follows: (See fig. 4-2.)

(1) Connect a decade resistor, set to 2,000 ohms, across receptacle pins J1-HH and J1-v.

(2) Set the MONITOR SELECT switch to YAW.

(3) Connect a jumper across pins J1-FF and J1-GG. For each combination of switch settings, the dmm shall read as listed below.

YAW SWITCH	MONITOR SELECT DRIVE/FDBK	DMM READING
0	SELF FDBK	+0.500 To +0.500
MAX EXT	HI DRIVE	+12.0 To +14.0
85% EXT	HI DRIVE	+8.34 To+ 10.62
85% EXT	RTN DRIVE	+0.480 To +0.600
0	HI DRIVE	-0.500 To +0.500
85% RETR	HI DRIVE	-8.34 To -10.62
85% RETR	RTN DRIVE	-0.480 To -0.600
MAX RETR	HI DRIVE	-12.0 To -14.0

- (4) Remove the jumper wire.

NOTE

When a test includes a requirement that an ac voltage be in-phase or out-of-phase, oscilloscope channel A must be connected across the digital multimeter. Oscilloscope channel B must be connected to the ac source and the oscilloscope externally triggered from the ac source.

- (5) Connect a variable ac power supply to receptacle pins J1-FF and J1-GG. Voltage shall be 180° out of phase with respect to the 115 volt ac source at J 1-B.

- (a) Set the YAW switch to MAX EXT.

- (b) Adjust the ac power supply for .0000 on the dmm.

- (c) With an external digital multimeter, set to measure ac volts, measure the output, voltage of the ac power supply. The voltage shall be 1.720 to 2.190 vat.

- (6) Connect a variable ac power supply to receptacle pins J1-FF and J1-GG. Voltage must be in phase with respect to the 115 volt ac source at J1-B.

- (a) Set the YAW switch to MAX RETR.

- (b) Adjust external voltage source to reach .0000 on the dmm.

- (c) Connect an external digital multimeter, set to measure ac volts, to the output of the ac power supply. The voltage shall be 1.720 to 2.190 volts ac.

- (7) Disconnect the external power supply and decade resistor.

4-33. Gyro test. (See fig. 4-3.) This test ensures that the test set circuits which evaluate the output of the pitch, roll, heading, and heading error signals function as required. **(See FO-8 for connector pin patterns.)**

- a. Fabricate the test aid. (See fig. 4-3, sheet 2.)

- b. Set the METER SOURCE switch to GYRO TEST.

- c. Perform the following tests with ac power supply connected to the pins listed below and GYRO TEST SIGNAL MONITOR switches set to the position listed. The dmm shall read within the range listed. For (open) readings, connect a 10K-ohm resistor across HI and LO binding posts.

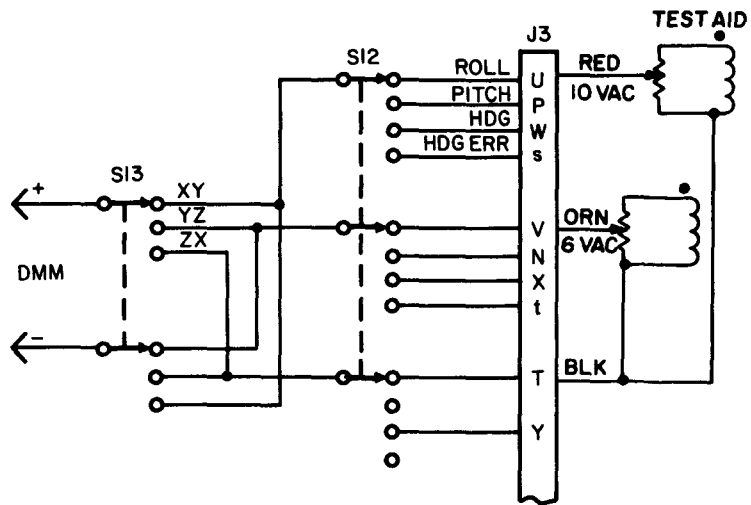

ROLL

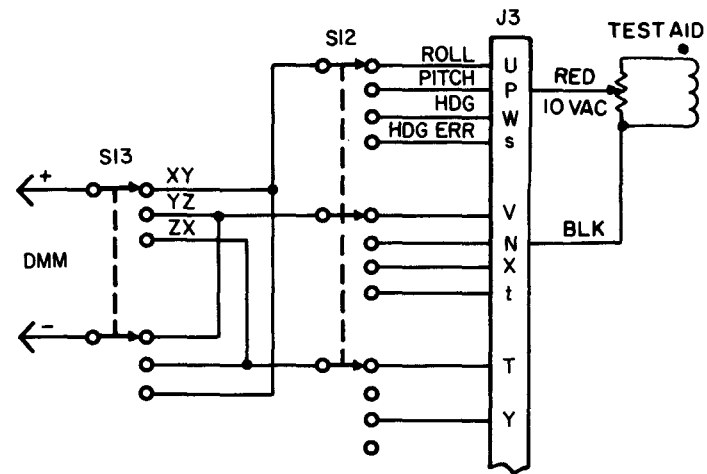

PITCH

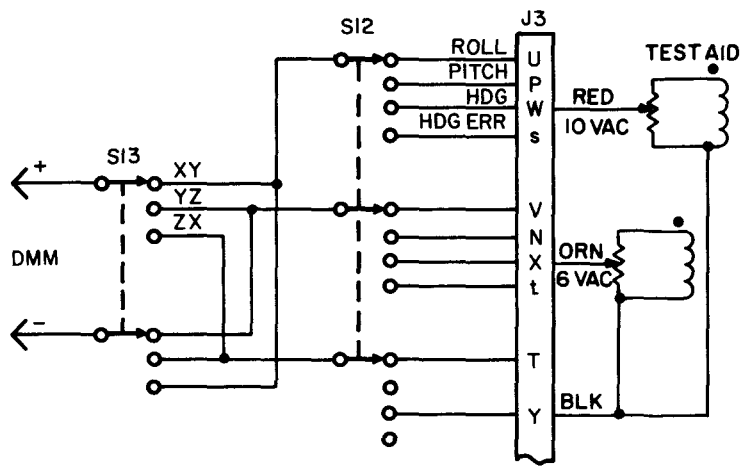

HDG

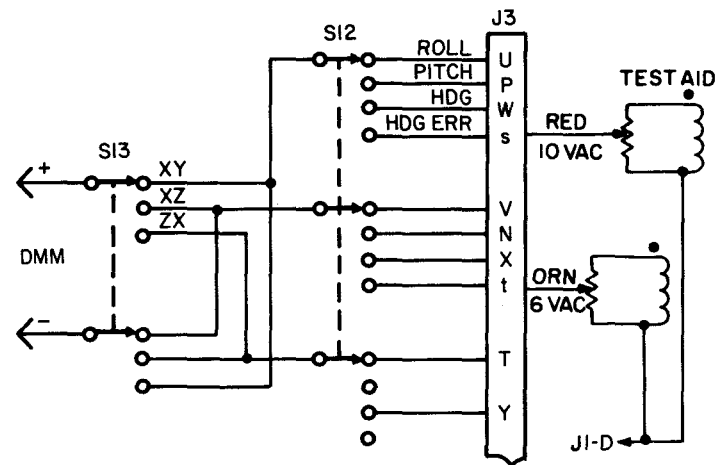

HDG ERR

NOTE
COMPLETE TEST AID
CIRCUIT IS ON SHEET 2

470-TMDE-ALTS-33

Figure 4-3. Gyro Test Setup and Test Aid (Sheet 1 of 2)

TEST AID

CONNECT AS
SPECIFIED ON
SHEET I

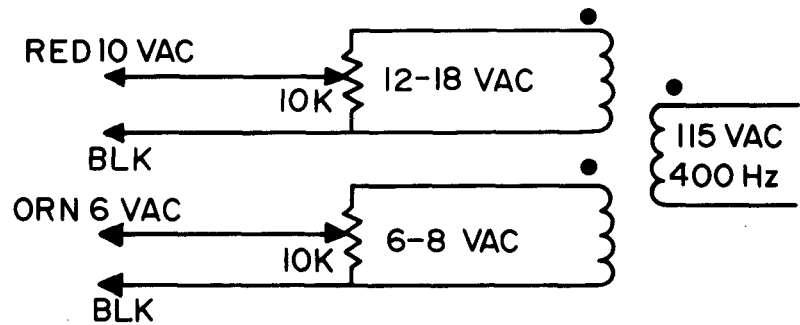

● INDICATES START
OF WINDING

A 47D-TMDE-ALTS-36

Figure 4-3. Gyro Test Setup and Test Aid (Sheet 2 of 2)

APPLIED TEST VOLTAGE		GYRO TEST SWITCHES			
10 VAC (line)	+6 VAC (line)	Neutral	Left	Right	DMM
J3-U	J3-V	J3-T	ROLL	XY	+3.6 To +4.4
J3-U	J3-V	J3-T	ROLL	YZ	+5.4 To +6.6
J3-U	J3-V	J3-T	ROLL	ZX	-9.0 To -11.0
J3-P	NC	J3-N	PITCH	XY	+9.0 To +11.0

NOTE

Connect a 10K ohm resistor across the HI and LO binding posts.

J3-P	NC	J3-N	PITCH	YZ	0 (open)
J3-P	NC	J3-N	PITCH	ZX	0 (open)

NOTE

Disconnect 10K ohm resistor.

J3-W	J3-X	J3-Y	HDG	XY	+3.6 To +4.4
J3-W	J3-X	J3-Y	HDG	YZ	+5.4 To +6.6
J3-W	J3-X	J3-Y	HDG	ZX	-9.0 To -11.0
J3-s	J3-t	NC	HDG ERR	XY	+3.6 To +4.4

NOTE

Connect a 10K ohm resistor across HI and LO binding posts.

J3-s	J3-t	NC	HDG ERR	YZ	0 (open)
J3-s	J3-t	NC	HDG ERR	ZX	0 (open)

d. Disconnect 10K-ohm resistor. Disconnect ac power supply.

4-34. CPT MONITOR Test. This test insures that the CPT MONITOR and METER SOURCE circuits function as required. Each ac test signal shall be in phase with the 115 volt ac source at J1-B. All sources shall have a common return. (See fig. 4-4.) (see **FO-8 for connector pin patterns.**)

NOTE

When a test includes a requirement that an ac voltage be in-phase or out-of-phase, oscilloscope channel A must be connected across the digital multimeter. Oscilloscope channel B must be connected to the ac source and the oscilloscope externally triggered from the ac source.

AFS LINE TEST SET

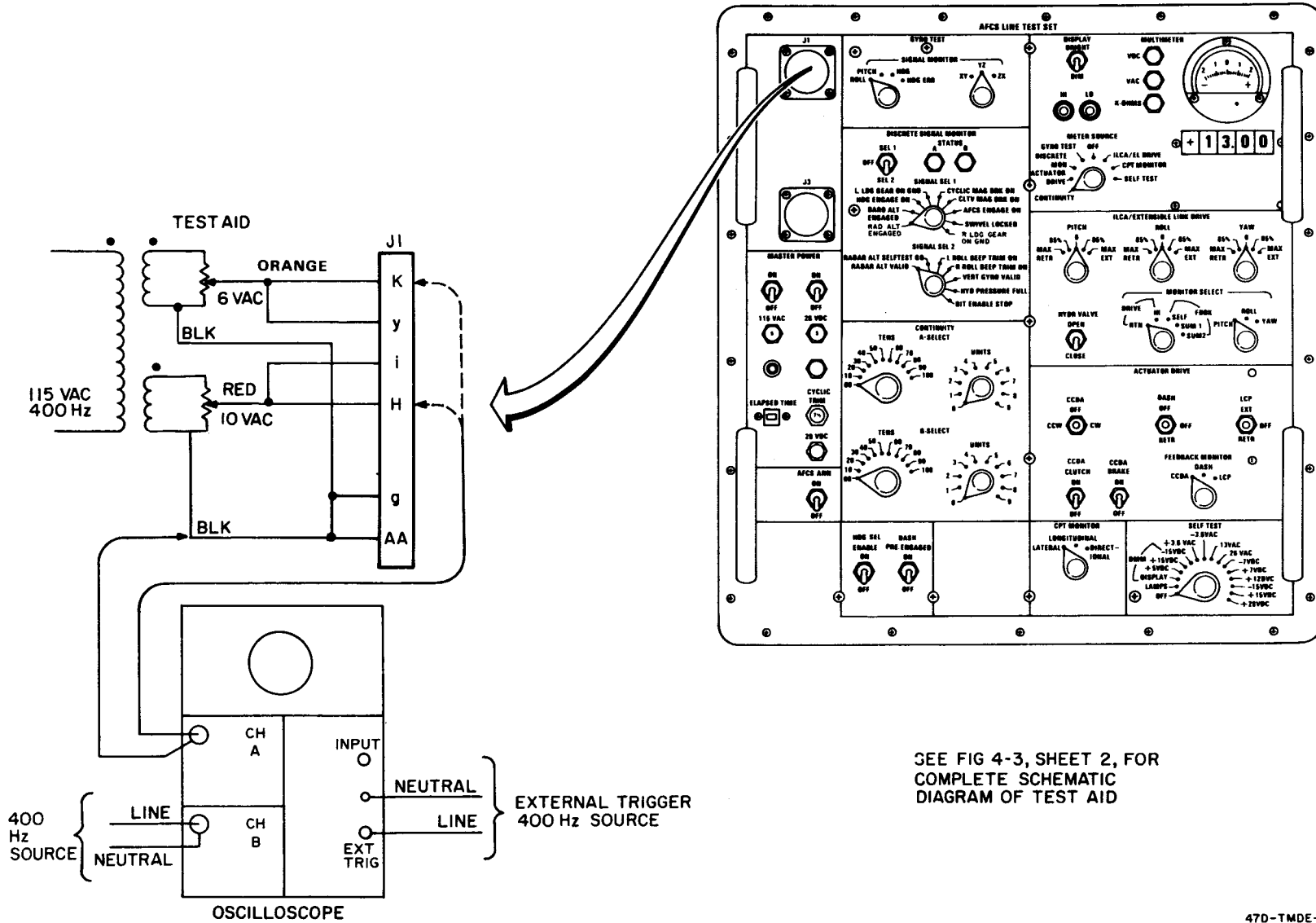

SEE FIG 4-3, SHEET 2, FOR COMPLETE SCHEMATIC DIAGRAM OF TEST AID

Fig. 4-4. CPT Monitor Test Setup

- a. Set the METER SOURCE switch to CPT MONITOR.
- b. Set the CPT MONITOR switch to LATERAL.
- c. Connect a jumper wire between J 1-i and J 1-H. Connect a jumper wire between J 1-AA and J 1-g. Connect a jumper wire between J1-K and J1-y.
- d. Connect the 10 volt ac power supply between J1-i (line) and J1-AA.
- e. Connect the 6 volt ac power supply between J1-K (line) and J1-AA.
- f. Adjust test aid circuit connected to receptacle pins J1-i (line) and J1-H to 10 volt ac.
- g. Adjust test aid circuit connected to receptacle pins J1-K (line) and J1-y to 6 vat. The dmm shall indicate +9 vac to +11.
- h. Set the CPT MONITOR switch to LONGITUDINAL. The dmm shall indicate -3.6 to -4.4.
- i. Set the CPT MONITOR switch to DIRECTIONAL. The dmm shall indicate -5.4 to -6.6.
- j. Disconnect the test setup.

4-35. Actuator Drive Test. This test ensures that the actuator drive circuits and feedback monitor circuits to dmm function as required. **(See FO-8 for connector pin patterns.)**

a. Test actuator drive circuits as follows:

- (1) Connect digital multimeter, set to measure ac volts to receptacle pins J3-E (line) and J3-C.
- (2) Set the CCDA switch to CCW. Multimeter shall read 2.0 to 3.0 volts ac.
- (3) Set the CCDA switch to CW. The multimeter shall read 2.0 to 3.0 volts ac.
- (4) Set the CCDA switch to OFF. The multimeter shall read 0 volt.
- (5) Disconnect the multimeter.
- (6) Connect the multimeter, set to measure dc volts, across receptacle pins J3-HH (+) and J3-C.
- (7) Set the DASH switch to RETR. The multimeter shall read +1 to -1 volt dc.
- (8) Set the DASH switch to EXT. The multimeter shall read +26 to +30 volts dc.
- (9) Set the DASH switch to OFF. The multimeter shall read 0 volt.
- (10) Disconnect the multimeter.

(11) Connect a digital multimeter, set to read dc volts, to the pins listed below. Set the LCT switch to the position listed. The multimeter shall read the voltage listed.

DIGITAL MULTIMETER CONNECTION	LCT SWITCH POS.	DIGITAL MULTIMETER READING
J1-S (+) ToJ1-C	EXT	+26 To +30 Vdc
J1-S (+) ToJ1-C	RET	0 Vdc
J1-S (+) ToJ1-C	OFF	0 Vdc
J1-T (+) ToJ1-C	RET	+26 To +30 Vdc
J1-T (+) ToJ1-C	EXT	0 Vdc
J1-T (+) ToJ1-C	OFF	0 Vdc

(12) Disconnect the multimeter.

(13) Connect the digital multi meter, set to measure dc volts, across the pins listed below. Set CCDA BRAKE and CCDA CLUTCH switches to the position listed. The multimeter shall read the voltage listed.

DIGITAL MULTIMETER CONNECTION	BRAKE SWITCH	CLUTCH SWITCH	DIGITAL MULTIMETER READING
J1-c (+) ToJ1-C	OFF	OFF	0 Vdc
J1-c (+) ToJ1-C	ON	OFF	0 Vdc
J1-c (+) ToJ1-C	OFF	ON	+26 To +30 Vdc
J1-b (+) ToJ1-C	OFF	OFF	0 Vdc
J1-b (+) ToJ1-C	ON	OFF	+26 To +30 Vdc
J1-b (+) ToJ1-C	OFF	ON	+26 To +30 Vdc
J1-b (+) ToJ1-C	ON	ON	+26 To +30 Vdc

(14) Set the CCDA CLUTCH and CCDA BRAKE switch to OFF,

(15) Disconnect the multimeter.

b. Test feedback monitor circuits as follows:

(1) Set the METER SOURCE switch to ACTUATOR DRIVE.

(2) Connect variable dc power supply to pins listed below. Connect the digital multimeter across the power supply. Set the FEEDBACK MONITOR switch to the position listed. The dmm shall indicate the voltage listed.

APPLIED TEST VOLTAGE	COMMON	FEEDBACK MON. SWITCH	DMM (VDC) READING
+10VDC			
J3-w	J3-C	DASH	+9.0 To +11.0
J3-x	J3-C	LCT	+9.0 To +11.0
J3-g	J3-C	LCT	+9.0 To +11.0
J3-F	J3-C	LCT	+9.0 To +11.0

(3) Disconnect external dc power supply.

(4) Set the FEEDBACK MONITOR switch to CCDA.

(5) Connect an ac power supply to receptacle pins J3-e (line) and J3-f. Connect the digital multimeter, set to measure ac volts, across the power supply.

(6) Adjust power supply for 10 volts ac on the digital multimeter. The dmm shall read +9.0 to +11.0.

(7) Disconnect the ac power supply.

(8) If no further power-on testing is to be done, shut down and disconnect the test set as follows:

- (a) Set both MASTER POWER switches to OFF.
- (b) Shut down external power and disconnect all test connections from the test set.

4-36. AFCS ANN Circuit Test. This test checks the operation of the AFCS ANN switch circuit. (See FO-8 for connector pin patterns.)

- a. Connect digital multimeter set to measure resistance to receptacle pins J3-u and J1-C.
- b. Set the AFCS ANN switch to ON. The multimeter shall read 0 to 2 ohms.
- c. Set the AFCS ANN switch to OFF. The multimeter shall read infinity.
- d. Disconnect the multimeter.

4-37. HDG SEL ENABLE Circuit Test. This test checks the operation of the HDG SEL ENABLE switch circuit. (See FO-8 for connector pin patterns.)

- a. Connect a digital multi meter, set to measure resistance, to pins J1-V and J1-C.
- b. Set the HDG SEL ENABLE switch to ON. The multimeter shall read 0 to 2 ohms.
- c. Set the HDG SEL switch to OFF. The multimeter shall read infinity.
- d. Disconnect the multimeter.

4-38. DASH PRE-ENGAGE Circuit Test. This test checks the operation of the DASH PRE-ENGAGE switch circuit. (See FO-8 for connector pin patterns.)

- a. Connect digital multimeter, set to measure resistance, to receptacle pins J3-Z and J1-C.
- b. Set the DASH PRE-ENGAGE switch to ON. The multimeter shall read 0 to 2 ohms.
- c. Set the DASH PRE-ENGAGE switch to OFF. The multimeter shall read infinity.
- d. Disconnect the multimeter.

Chapter 5

ILLUSTRATED PARTS BREAKDOWN

SECTION I INTRODUCTION

5-1. Purpose.

This chapter describes and illustrates the assemblies and detail parts required for maintenance of AFCS Line Test Set 145G0009-1. The information contained in this chapter is for use by personnel authorized in requisitioning, storing, issuing, and identifying repair parts for the test set.

5-2. Reference Designation Index.

This index consists of all the reference designations shown on schematic and wiring diagrams and on subassemblies of this test set. The index is arranged in columns as follows:

- a.* The Reference Designation column contains the reference designations in alphanumerical sequence. Reference Designation numbers for detail parts of electronic components are prefixed with the Reference Designation number for the component or subassembly.
- b.* The Figure and Index number column contains the figure and item number assigned to parts having electrical and electronic reference designation codes.

REFERENCE DESIGNATION INDEX

REFERENCE DESIGNATION	FIGURE	INDEX
A1	5-3	103
A2	5-3	25
A3	5-3	26
CB1, CB2	5-3	77
CB3	5-3	76
C1	5-3	52
DS1	5-3	74
DS2 thru DS6	5-3	72
DS7	5-3	84
DS8	5-3	85
E1	5-3	10
FL1 thru FL4	5-3	47
J1	5-3	5
J3	5-3	6
J4	5-3	45

REFERENCE DESIGNATION INDEX (Continued)

REFERENCE DESIGNATION	FIGURE	INDEX
K1, K2	5-3	49
M1	5-3	78
M2	5-3	13
PS1 thru PS4	5-3	20
PS5	5-3	40
P1	5-3	101
P2, P3	5-3	29
P4	5-3	46
R1	5-3	58
R2	5-3	57
R3	5-3	51
R4	5-3	56
R5	5-3	55
S1, S7, S9	5-3	79
S2, S6	5-3	80
S3, S5	5-3	87
S4	5-3	87.1
S8	5-3	81
S10, S30, S31	5-3	95
S11, S13, S15, S16	5-3	89
S12	5-3	93
S14	5-3	92
S17	5-3	91
S18	5-3	88
S19, S20, S21	5-3	90
S22	5-3	86
S23, S24	5-3	94
S25	5-3	97
S26, S28	5-3	96
TB1	5-3	50
TB2	5-3	55
TP1	5-3	82
TP2	5-3	83
T1	5-3	42
T2	5-3	44
W1	5-1	5
W1	5-2	1
W1P1	5-2	2
W1P2	5-2	3
W2	5-1	6
W2	5-2	1
W2P1	5-2	2
W2P2	5-2	3
W3	5-1	7
W3	5-2	1
W3P1	5-2	2
W3P2	5-2	3

5-3. Index of Part Numbers.

This index contains a complete listing of all items shown in the Detailed Parts List compiled in alphanumeric sequence. The index is arranged in columns as follows:

a. The Part Number Column contains the part numbers of the manufacturer of the part or the part number assigned to it by the Boeing Vertol Co. Requisition parts thru TM 55-4920-429-23P.

(1) Part number arrangement begins at the extreme left position and continues, one position at a time, until all parts are arranged in sequence. The order of precedence, beginning the part number arrangement at the extreme left (first) position, is as follows:

- Letters A through Z for the alpha index
- Numerals 0 through 9 for the numeric index

(2) The order of precedence in continuing the part number arrangement on the second and succeeding positions of the part number from left to right is as follows:

- Space (blank column)
- Diagonal (/)
- Point (.)
- Dash or hyphen (-)
- Letters A through Z, then
- Numerals 0 through 9

Alphabetic (letter) O is listed as numerical zero's.

Examples of part number sequence:

- ABC0158
- AN509-10
- AN509C10R7
- A39539-10-001
- ZB45-37C
- 10-60732-3
- 10001
- 11
- 112304
- 5008CW
- 65-2716-27
- 6553

b. The Figure and Index number columns contain the figure and index number listing/s assigned to a part.

INDEX OF PART NUMBERS

PART NUMBER	FIGURE	INDEX
LH90/1	5-3	74
MS17322-10	5-3	78
MS17322-6	5-3	78
MS18237-1WT	5-3	75
MS21044 C04	5-2	6
MS21044 C04	5-3	4
MS21044 C06	5-3	48
MS24523-27	5-3	87
MS24523-22	5-3	79

INDEX OF PART NUMBERS (Continued)

PART NUMBER	FIGURE	INDEX
MS24524-22	5-3	80
MS24524-27	5-3	87.1
MS24693-272	5-3	14
MS25068-21	5-3	86
MS25237-327	5-3	73
MS25237-387	5-3	73
MS25244-5	5-3	77
MS25244-7	5-3	76
MS3120E16-26P	5-3	45
MS3126E16-26S	5-3	46
MS3417-24N	5-2	4
MS3470L24-61P	5-3	5
MS3470L24-61PX	5-3	6
MS3471L24-61P	5-2	3
MS3471L24-71PX	5-2	3
MS3475L24-61S	5-2	2
MS3476L24-61SX	5-2	2
MS35059-23	5-3	81
MS35333-70	5-3	3
MS35333-71	5-3	36
MS35333-73	5-3	19
MS90310-231	5-3	95
MS91528-1K2B	5-3	7
MS91528-2K2B	5-3	8
M24308/2-4	5-3	101
M24308/25-6	5-3	102
M3786/36-0229	5-3	91
M3786/36-0530	5-3	90
M3786/4-5018	5-3	89
M3786/4-5019	5-3	93
M3786/4-5033	5-3	97
M3786/4-5053	5-3	94
M3786/4-5081	5-3	92
M3786/4-5096	5-3	88
M39014-01-1513	5-3	52
M45938-3-6C	5-3	33
M45938-3-6CL	5-3	38
M45938-3-8CL	5-3	61
M45938-3-8CL	5-3	64
M45938-3-8CL	5-3	67
M45938-3-8CL	5-3	70
M55302/27-06	5-3	29
M5757-23-001	5-3	49
M83723-15S14A	5-2	4
M83723/85A1415N	5-2	3
M83723/86A1415N	5-2	2
NAS1625-3-8	5-3	18
NAS1635-00-2	5-1	2

INDEX OF PART NUMBERS (Continued)

PART NUMBER	FIGURE	INDEX
NAS1635-02-7	5-3	27
NAS1635-04-12P	5-3	11
NAS1635-04-14P	5-3	98
NAS1635-04-18	5-3	43
NAS1635-04-6	5-3	41
NAS1635-04-8	5-3	2
NAS1635-06-7	5-3	105
NAS1635-06-7P	5-3	35
NAS1635-08-6	5-3	16
NAS1635-08-6P	5-3	107
NAS1635-3-10	5-1	8
NAS1685-06-6	5-3	21
NAS1786-06-36	5-3	106
NAS43DD0-28	5-3	100
NAS43DD0-30	5-3	99
RCR07G100JP	5-3	1
RNC55H1052FP	5-3	56
RNC55H7501FP	5-3	57
VS25113-4	5-1	3
10031356-101	5-3	47
10039725-102	5-3	44
10039726-102	5-3	20
10039726-104	5-3	40
10066999-101	5-1	4
10070110-101	5-3	42
100703031-114	5-3	110
10072877-101	5-3	13
145G0009-1	5-1	1
145G5202-1	5-2	5
145G5202-2	5-2	6
145G5202-3	5-2	7
145G5202-4	5-2	5
145G5202-5	5-2	6
145G5202-6	5-2	7
145G5202-7	5-2	5
145G5202-8	5-2	6
145G5202-9	5-2	7
145G5210-1	5-1	9
145G5210-1	5-3	1
145G5211-1	5-1	5
145G5211-1	5-2	1
145G5212-1	5-1	6

INDEX OF PART NUMBERS (Continued)

PART NUMBER	FIGURE	INDEX
145G5212-1	5-2	1
145G5213-1	5-1	7
145G5213-1	5-2	1
145G5225-1	5-3	109
145G5240-1	5-3	25
145G5243-1	5-3	26
145G5289-1	5-3	108
1997049-9	5-3	32
234G5215-1	5-3	60
234G5215-2	5-3	62
234G5216-1	5-3	66
234G5219-1	5-3	30
234G5219-2	5-3	34
414G5205-1	5-3	55
414G5205-2	5-3	59
414G5206-1	5-1	10
414G5207-1	5-3	12
414G5214-1	5-3	63
414G5214-2	5-3	65
414G5217-1	5-3	22
414G5217-2	5-3	23
414G5217-3	5-3	24
414G5218-1	5-3	37
414G5218-2	5-3	39
414G5221-1	5-3	50
414G5221-2	5-3	53
414G5222-1	5-3	17
414G5224-1	5-3	103
414G5237-1	5-3	104
422294-4	5-3	28
435486	5-3	10
437104-4	5-3	31
440688-4	5-3	85
440688-6	5-3	72
440688-9	5-3	84
441837-1	5-3	82
441837-2	5-3	83
459066-8	5-3	15

5-4. Detailed Parts List.

The text part of the Detailed Parts Lists is arranged in columns as follows:

a. Figure and Index Number. The number in the left position in the first column of each text page is the figure number. The number in the right position is the index number which keys the part number to the illustration when the part is illustrated. When a breakdown consists of both left- and right-hand assemblies, only left-hand parts are illustrated.

b. Part Number. This column contains the identifying number assigned to each part. If an item does not have a part number, NO NUMBER will appear in this column. A complete description of the item will be included in the description column. Requisition parts thru TM 55-4920-429-23P.

c. Description. This column lists a description of each part by Government standard, vendor, or manufacturer's drawing title. Included in this column, when required, are the following:

(1) A five-digit vendor code, preceded by the capital letter V. Vendor codes used in the Detailed Parts List are as follows:

Vendor Code Index	
CODE	VENDOR NAME AND ADDRESS
40931	Honeywell Inc. Honeywell Plaza Minneapolis, MN 55048
94580	Honeywell Inc. Avionics Div. 2600 Ridgway Parkway Minneapolis, MN 55413

(2) Abbreviations are used to describe parts. Abbreviations used in the Detailed Parts List areas follows:

ABBREVIATION	DESCRIPTION
AFCS	ADVANCED FLIGHT CONTROL SYSTEM
ALT	ALTERNATE
ASSY	ASSEMBLY
BKDN	BREAKDOWN
CW	CLOCKWISE
CCW	COUNTERCLOCKWISE
FIG	FIGURE
MAKEFR	MAKE FROM
PWR	POWER
U/W	USE WITH

(3) Oversize and undersize parts such as studs and bushings are listed immediately following the standard size part. The degree of fit is also stated.

(4) When an assembly is broken down in another figure, a reference to that figure is provided.

(5) When the next higher assembly appears in another figure, a reference to that figure is provided.

TM 55-4920-429-13

(6) Manufacturer's specification and source control drawing numbers are listed in the part number column. Equivalent vendor part numbers and codes are listed in the description column.

(7) For proper identification of details and next assemblies, the listings are subordinated in an indentation system. The indentation system shows the subordination of assembly in accordance with the following outline:

- 1 2 3 4 5 6 7
- DEVICE
- . ATTACHING PARTS FOR ASSEMBLY
- . ASSEMBLY
- . . ATTACHING PARTS FOR SUBASSEMBLY
- . . SUBASSEMBLY OF DEVICE
- . . . DETAIL PARTS OF SUBASSEMBLY

(8) Each Boeing part is given the number of the drawing from which the part is made. The drawings are numbered according to a system in which a prefix of three digits is used. Boeing-Vertol part numbers are prefixed with the numbers 114, 145, 165, 173, 234, 308, and 414.

(9) Specification and Source Control part numbers are listed in the part number column. Vendor equivalent part numbers are listed in the nomenclature column.

(a) In addition to the above, Boeing-Vertol standard parts listed are prefixed by the letters

NOTE

Vendor codes are not used for Boeing-Vertol, Boeing standard parts, Boeing-Kent, and military standard part numbers.

(10) Usable On Code—This column indicates the applicability of an item to other types or makes of equipment.

(11) Units per Assembly—This column lists the number of units required per assembly or subassembly. When more than one assembly is required, the total for these assemblies will be listed. The letters AR indicate as required. The letters REF are used on items that are listed for reference purposes.

SECTION II REPAIR PARTS LIST

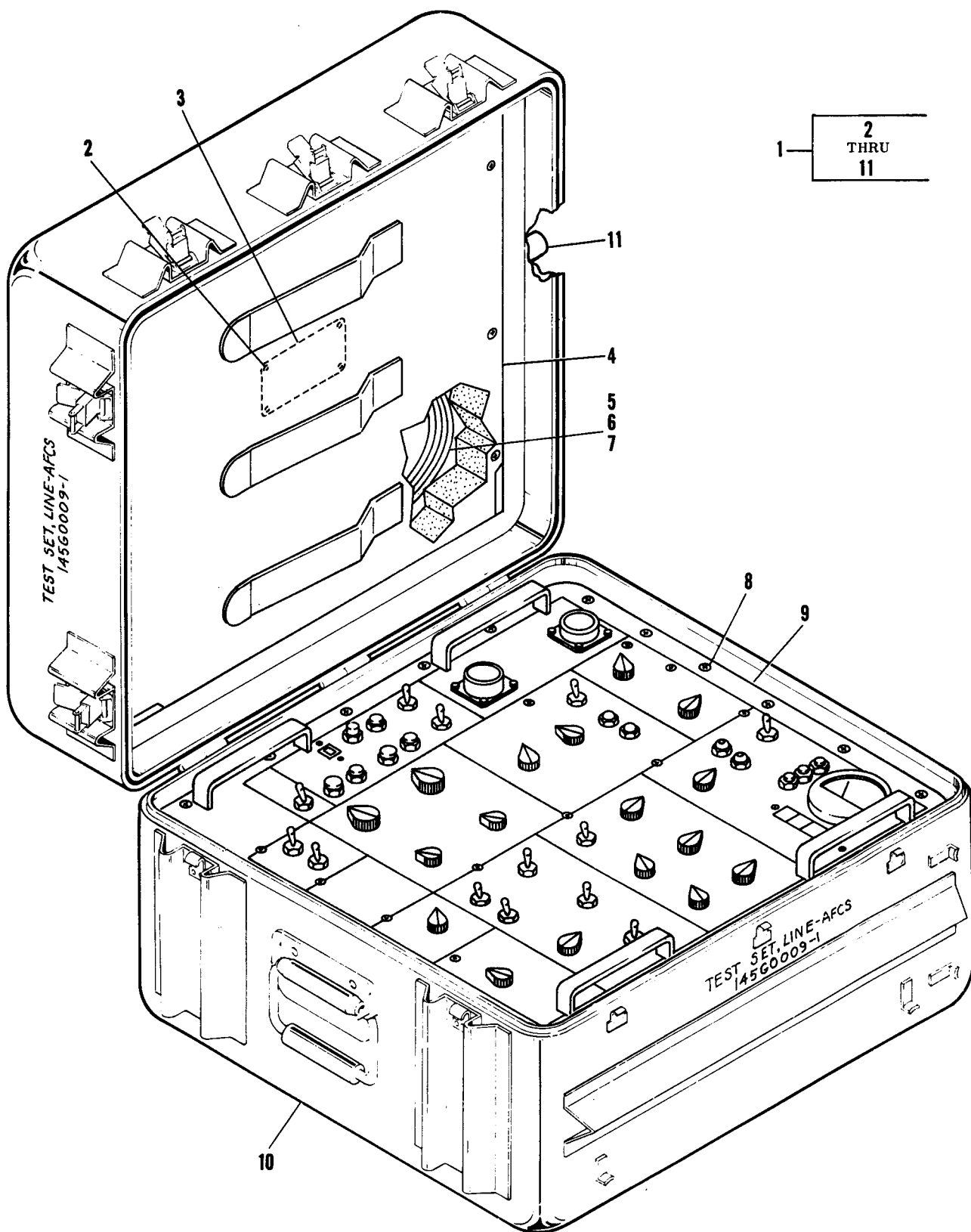

Figure 5-1. AFCS Line Test Set Assembly

FIGURE AND INDEX NO.	PART NUMBER	DESCRIPTION	UNITS PER ASSY	USABLE ON CODE
5-1- 1	145G0009-1	TEST SET,AFCS line	1	
2	NAS1635-00-	. SCREW,pan head	4	
3	VS25113-4	. PLATE,name	1	
4	10066999-101	. PACKING,foam insert	2	
5	145G5211-1	(V94580) . CABLE ASSY(W1)	1	
6	145G5212-1	see fig 5-2 for bkdn . CABLE ASSY(W2)	1	
7	145G5213-1	see fig 5-2 for bkdn . CABLE ASSY(W3)	1	
8	NAS1635-3-10	see fig 5-2 for bkdn . SCREW,pan head	23	
9	145G5210-1	. PANEL ASSY,test set	1	
10	414G5206-1	see fig 5-3 for bkdn . CASE(make 1997042-4,	1	
11	NO NUMBER	V94580) . RELIEF VALVE,AIR	1	

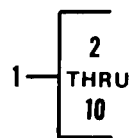
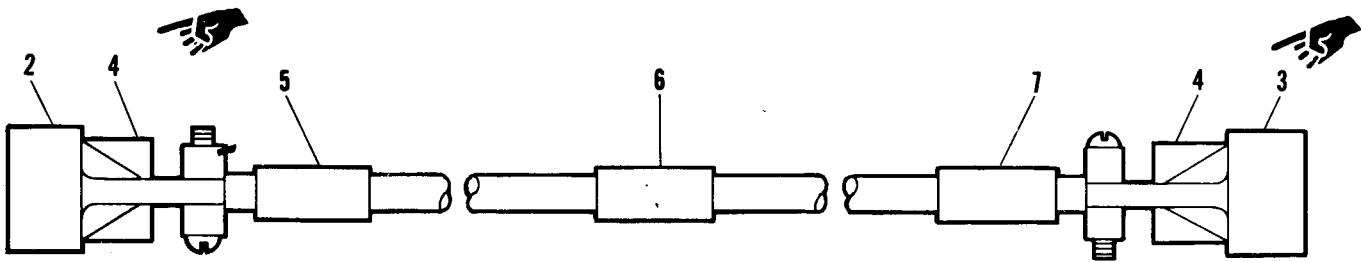

Figure 5-2. Cable Assy

FIGURE AND INDEX NO.	PART NUMBER	DESCRIPTION	UN PER ASSY	USABLE ON CODE
5-2-1	145	CABLE ASSY(W1)see fig 5-1	REF	
1	145G5212-1	for NHA CABLE ASSY(W2)see fig 5-1	REF	
1	145G5213-1	for NHA CABLE ASSY(W3)see fig 5-1	REF	
2	MS3475L24-61S	for NHA . CONNECTOR(W1P1)	1	
2	M83723/86A1415N	(u/w 145G5211-1) . CONNECTOR(W2P1)	1	
2	MS3476L24-61SX	(u/w 145G5212-1) . CONNECTOR(W3P1)	1	
3	MS3471L24-61P	(u/w 145G5213-1) . CONNECTOR(W1P2)	1	
3	M83723/85A1415N	(u/w 145G5211-1) . CONNECTOR(W2P2)	1	
3	MS3471L24-71PX	(u/w 145G5212-1) . CONNECTOR(W3P2)	1	
4	MS3417-24N	(u/w 145G5213-1) . STRAIN RELIEF	2	
4	M83723/15S14A	(u/w 145G5211-1 and 145G5213-1) . STRAIN RELIEF	2	
5	145G5202-1	(u/w 145G5212-1) . TAG,identification,POSN 1	1	
5	145G5202-4	(u/w 145G5211-1) . TAG,identification,POSN 1	1	
5	145G5202-7	(u/w 145G5212-1) . TAG,identification,POSN 1	1	
6	145G5202-2	(u/w 145G5213-1) . TAG,identification,POSN 1	1	
6	145G5202-5	(u/w 145G5212-1) . TAG,identification,POSN 2	1	
6	145G5202-8	(u/w 145G5211-10) . TAG,identification,POSN 2	1	
7	145G5202-3	(u/w 145G5212-1) . TAG,identification,POSN 2	1	
7	145G5202-6	(u/w 145G5213-1) . TAG,identification,POSN 2	1	
7	145G5202-9	(u/w 145G5211-1) . TAG,identification,POSN 3	1	
		(u/w 145G5212-1) . TAG,identification,POSN 3	1	
		(u/w 145G5213-1) . TAG,identification,POSN 3	1	

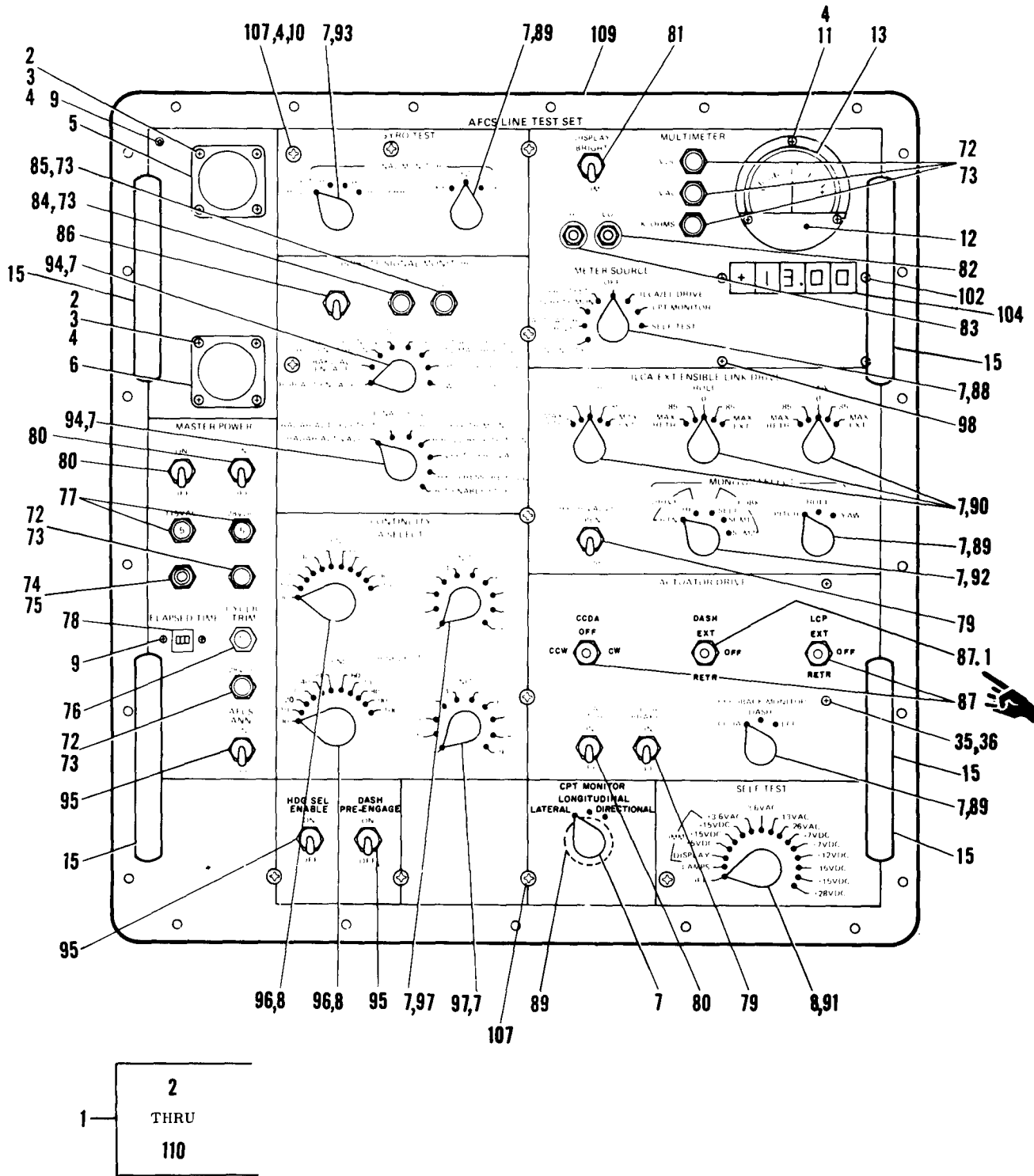

Figure 5-3. Panel Assy (Sheet 1 of 4)

FIGURE AND INDEX NO.	PART NUMBER	DESCRIPTION	UNITS PER ASSY	USABLE ON CODE
5-3- 1	145	PANEL ASSY, test set	REF	
2	NAS1635-04-8	see fig.5-1 for NHA		
3	MS35333-70	. SCREW	12	
4	MS21044	. WASHER	11	
5	MS3470L24-61P	. NUT	22	
6	MS3470L24-61PX	. CONNECTOR(J1)	1	
7	MS91528-1K2B	. CONNECTOR(J3)	1	
8	MS91528-2K2B	. KNOB	14	
9	NAS1685-04-6R	. KNOB	3	
10	435486	. SCREW	3	
11	NAS1635-04-12P	. TERMINAL, lug (V94580)	1	
12	414G5207-1	. SCREW, pan pan head	3	
13	10072877-101	. COVER, meter meter	1	
14	MS24693-272	. MICROAMMETER, DC DC (V94580)	1	
15	459066-8	(M2		
16	NAS1635-08-6	. SCREW, machine, machine, flat head	8	
17	414G5222-1	. HANDLE (V94580)	4	
18	NAS1625-3-8	. SCREW, pan pan head	17	
19	MS35333-73	. PLATE, bottom bottom	1	
20	10039726-102	. SCREW	20	
21	NAS1685-06-6	. WASHER	20	
22	414G5217-1	. POWER SUPPLY (PS1 THRU PS4)	4	
23	414G5217-2	(V94580)		
24	414G5217-3	. SCREW	18	
25	145G5240-1	. RETAINER, card card	1	
26	145G5243-1	. CHANNEL	1	
27	NAS1635-02-7	. RUBBER	1	
28	422294-4	. CARD ASSY, digital digital	1	
29	M55302/27-06	multimeter circuit		
30	234G5219-1	. CARD ASSY, signal signal monitor	1	
31	437104-4	circuit(A3)		
32	1997049-9	. SCREW	4	
33	M45938-3-6C	. NUT, self-locking self-locking (V94580)	4	
34	234G5219-2	. CONNECTOR (P2, P3)	2	
35	NAS1635-06-7P	. BASE ASSY, card cage	1	
36	MS35333-71	. RIVET (V94580)	12	
37	414G5218-1	. HOLDER CIRCUIT CARD	6	
38	M45938-3-6CL	(V94580)		
39	414G5218-2	. NUT	3	
40	10039726-104	. BASE, card card cage	1	
41	NAS1635-04-6	. SCREW	2	
42	10070110-101	. WASHER, lock lock	16	
43	NAS1635-04-18	. TOP ASSY, card card cage	1	
44	10039725-102	. NUT	9	
45	MS3120E16-26P	. TOP, card card cage	1	
46	MS3126E16-26S	. TOP, card card cage	1	
47	10031356-101	. POWER SUPPLY (PS5) (PS5) (V94580)	1	
		. SCREW, pan pan head	4	
		. TRANSFORMER, power(T1) power(T1) (V94580) ..	1	
		. SCREW	2	
		. TRANSFORMER, power(T2) power(T2) (V94580) ..	1	
		. CONNECTOR (J4)	1	
		. CONNECTOR (P4)	1	
		. FILTER, radio radio frequency	4	
		(FL 1 thru FL FL 4) (V94580)		

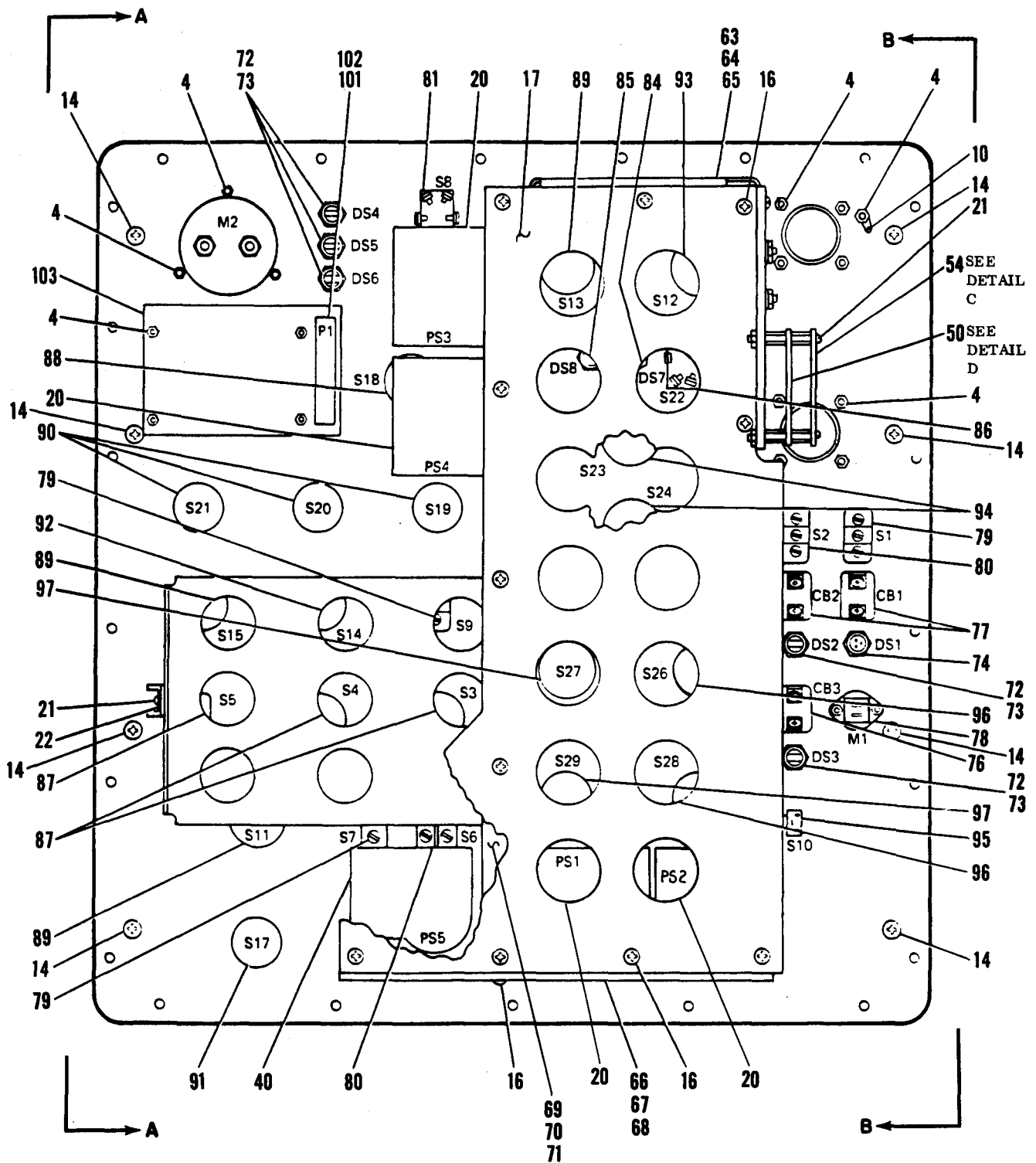
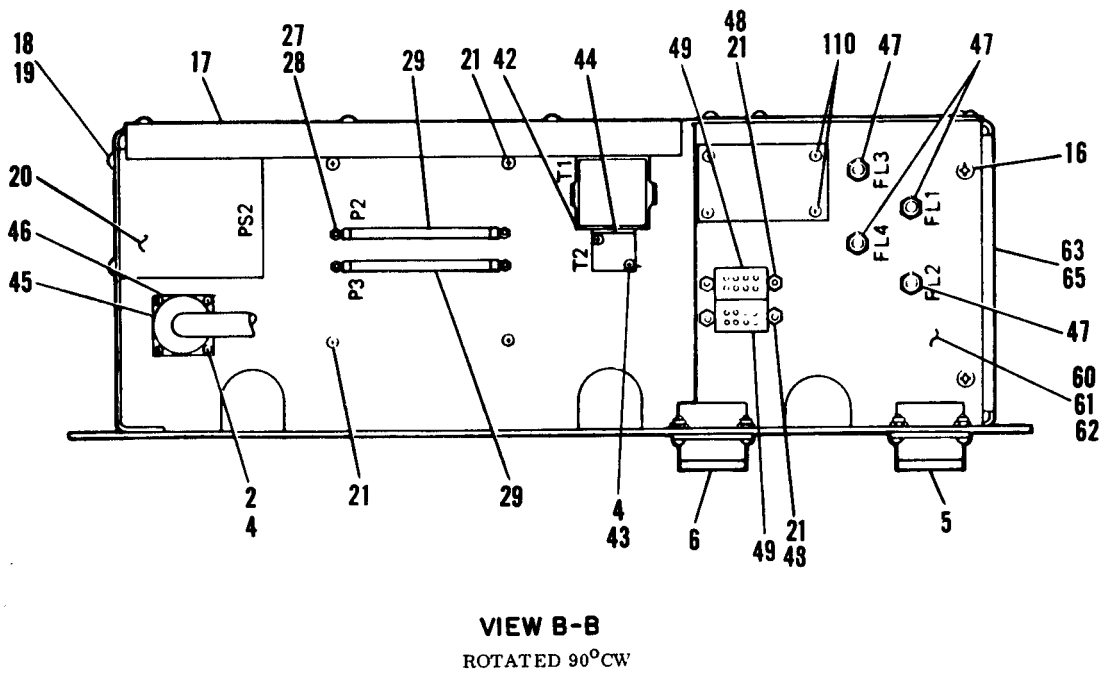
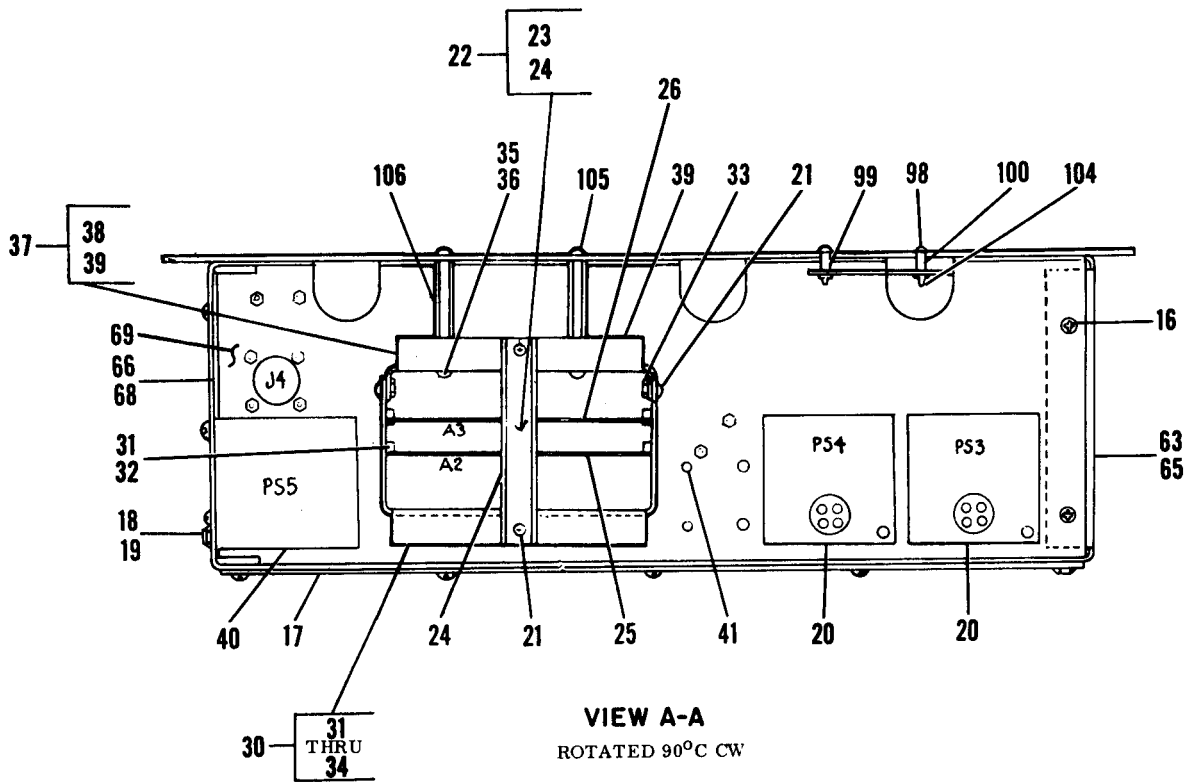

Figure 5-3. Panel Assy (Sheet 2 of 4)

FIGURE AND INDEX NO.	PART NUMBER	DESCRIPTION	UNITS PER ASSY	USABLE ON CODE
5-3-48	MS21044 C06	. NUT	8	
49	M5757/23-001	. RELAY (K1)	2	
50	414G5221-1	TERMINAL BOARD ASSY(TB1) (TB1)	1	
51	RLR07C3921FR	. . RESISTOR(R3)3.2K	1	
52	M39014/01-1593	. . CAPACITOR(C1)0.1UF	1	
53	414G5221-2	. . BOARD,modified modified	1	
54	414G5205-1	TERMINAL BOARD ASSY(TB2) (TB2)	1	
55	RCR07G100JP	. . RESISTOR (R5)	1	
56	RNC55H1052FS	. . RESISTOR(R4) (R4)	1	
57	RNC55H7501FS	. . RESISTOR(R2) (R2)	1	
58	RNC55H1002BF	. . RESISTOR(R1) (R1)	1	
59	414G5205-2	. . BOARD,modified modified	1	
60	234G5215-1	. BRACKET ASSY,relay relay	1	
61	M45938/3-8CL	. . NUT,self self locking	4	
62	234G5215-2	. . BRACKET,relay relay	1	
63	414G5214-1	. BRACKET ASSY,end end	1	
64	M45938/3-8CL	. . NUT	8	
65	414G5214-2	. . BRACKET, end	1	
66	234G5216-1	. SUPPORT ASSY,power, power, supply	1	
67	M45938/3-8CL	. . NUT,self self locking	8	
68	414G5216-2	. . SUPPORT,power power supply	1	
69	234G5223-1	. SUPPORT,assy,chassis assy, chassis	1	
70	M45938/3-8CL	. . NUT,self self locking	10	
71	234G5223-2	. . SUPPORT,chassis chassis	1	
72	440688-6	. LIGHT,indicator(V94580) indicator(V94580) (DS2 thru DS6)	5	
73	MS25237-387	. LAMP	7	
	MS25237-327	. LAMP (alternate for MS25237-387)	7	
74	LH90/1	. HOUSING,indicator indicator light (DS1)	1	
75	MS18237-1WT	. LAMP	1	
76	MS25244-7	. CIRCUIT BREAKER(CB3) (CB3)	1	
77	MS25244-5	. CIRCUIT BREAKER(CB1,CB2) (CB1,CB2)	2	
78	MS17322-6	. METER(M1)	1	
78	MS17322-10	METER(alternate (alternate for MS17322-6)	1	
79	MS24523-22	. SWITCH,toggle(S1,S7 toggle(S1,S7 and S9)....	3	
80	MS24524-22	. SWITCH,toggle(S2,S6) toggle(S2,S6)	2	
81	MS35059-23	. SWITCH,toggle(S8) toggle(S8)	1	
82	441837-1	. POST-BINDING(TP2) (TP2)(V94580)	1	
83	441837-2	. POST-BINDING(TP1) (TP1)(V94580)	1	
84	440688-9	. LIGHT,indicator(DS7) indicator(DS7)	1	
85	440688-4	. LIGHT,pilot(DS8) pilot(DS8)	1	
86	MS25068-21	. SWITCH,toggle(S22) toggle(S22)	1	
87	MS24523-27	. SWITCH,momentary(S3) momentary(S3,S5)	2	
87.1	MS24524-27	. SWITCH,momentary(S4) momentary(S4)	1	
88	M3786/4-5096	. SWITCH,rotary(S18) rotary(S18)	1	
89	M3786/4-5018	. SWITCH,rotary rotary (S11,S13,S15 and S16)	4	
90	M3786/36-0530	. SWITCH,rotary rotary (S19 thru S21)	3	
91	M3786/36-0229	. SWITCH,rotary(S17) rotary(S17)	1	
92	M3786/4-5081	. SWITCH,rotary(S14) rotary(S14)	1	



47D-TMDE-ALTS-5

Figure 5-3. Panel Assy (Sheet 3 of 4)

FIGURE AND INDEX NO.	PART NUMBER	DESCRIPTION	UNITS PER ASSY	USABLE ON CODE
		1 2 3 4 5 6 7 67		
5-3- 93	M3786/4-5019	. SWITCH,rotary(S12)	1	
94	M3786/4-5053	. SWITCH,rotary(S23,S24)	2	
95	MS90310-231	. SWITCH,toggle	3	
96	10040386-103	(S10,S30 and S31) . SWITCH,rotary(V94580)	2	
97	M3786/4-5033	(S26,S28) . SWITCH,rotary(S27,S29)	2	
98	NAS1635-04-14P	. SCREW,machine	4	
99	NAS43DD0-30	. SPACER,screw	2	
100	NAS43DD0-28	. SPACER,screw	2	
101	M24308/2-4	. CONNECTOR(P1)	1	
102	M24308/25-6	. SCREW LOCK ASSY	1	
103	414G5224-1	. FILTER,display	1	
104	414G5237-1	. CARD ASSY,digital	1	
105	NAS1635-06-7P	display . SCREW,pan head	2	
106	NAS1786-06-36	. POST,electrical	2	
107	NAS1635-08-6P	. SCREW,pan head	11	
108	145G5289-1	. PLATE,identification	1	
109	145G5225-1	. PANEL,test set	1	
110	i00703031	. STANDOFF,male	8	
		(V94580)		

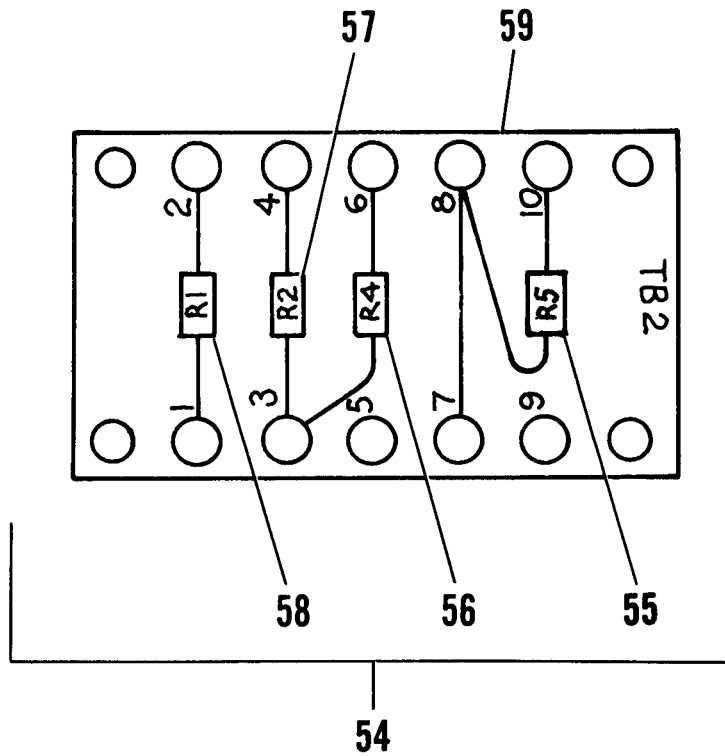

DETAIL D

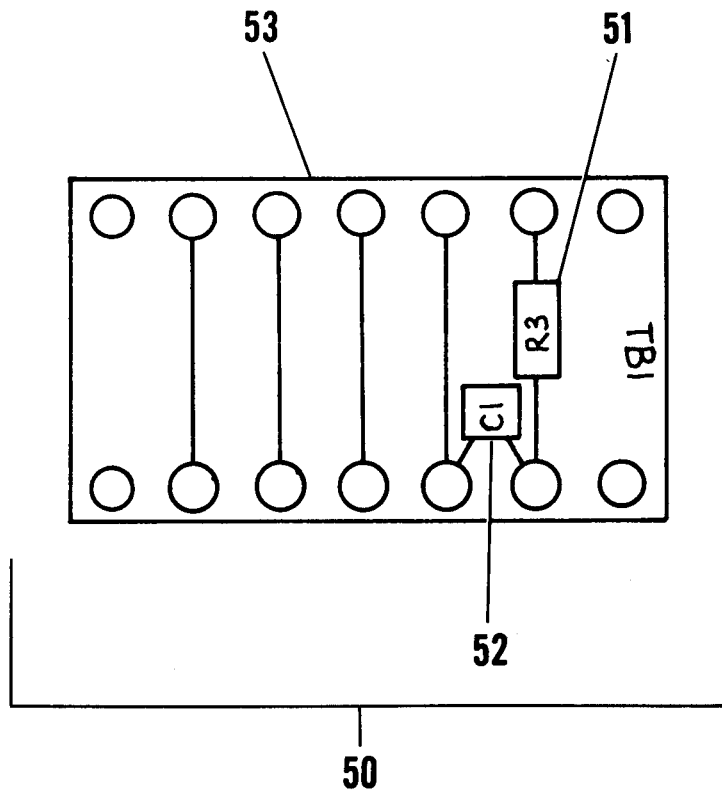

DETAIL C

Figure 5-3. Panel Assy (Sheet 4 of 4)

APPENDIX A

REFERENCES

Following is a list of references available to the organizational and intermediate repairman of AFCS Line Test Set.

DA Pam 25-30	Consolidated Index of Army Publications and Blank Forms
DA Pam 738-751	Functional Users Manual for The Army Maintenance Management System - Aviation (TAMMS-A)
FM 21-11	First Aid, Soldiers
TB 750-25-1	Maintenance of Supplies and Equipment, Army Metrology and Calibration System
TM 43-0139	Painting Instruction for Field Use
TM 1-1500-204-23 Series	General Aircraft Maintenance Manual
TM 55-1500-323-25	Organizational, Direct Support, General Support and Depot Maintenance Manual: Installation Practices for Aircraft Electric and Electronic Wiring
TM 55-1520-240-23	AVUM and AVIM Maintenance Manual, CH-47D Helicopter
TM 55-4920-429-23P	AFCS Line Test Set Repair Parts and Special Tools List
TM 750-244-2	Procedures for Destruction of Electronics Materiel to Prevent Enemy Use

APPENDIX B

MAINTENANCE ALLOCATION CHART

SECTION I INTRODUCTION

B-1 . MAINTENANCE ALLOCATION A CHART.

a. This Maintenance Allocation Chart (MAC) assigns maintenance functions in accordance with the Three Levels of Maintenance concept for army aircraft. These maintenance levels: Aviation Unit Maintenance (AVUM), Aviation Intermediate Maintenance (AVIM), and Depot Maintenance are depicted on the MAC as:

AVUM which corresponds to the O code in the Repair Parts and Special Tools List (RPSTL).

AVIM which corresponds to the F code in the Repair Parts and Special Tools List (RPSTL).

Depot which corresponds to the D code in the Repair Parts and Special Tools List (RPSTL).

b. The maintenance to be performed below depot and in the field is described as follows:

(1) Aviation Unit Maintenance (AVUM). AVUM activities will be staffed and equipped to perform high frequency *On-Equipment* maintenance tasks required to retain or return equipment to a serviceable condition. The maintenance capability of the AVUM will be governed by the MAC and limited by the amount and complexity of support equipment, facilities required, and number of spaces and critical skills available. The range and quantity of authorized spare modules/components will be consistent with the mobility requirements dictated by the air mobility concept.

(2) Aviation Intermediate Maintenance (AVIM). AVIM provides mobile, responsive *One Stop* maintenance support. (Maintenance functions which are not conducive to sustaining air mobility will be assigned to depot maintenance.) Performs all maintenance functions authorized to be done at AVUM. Repair of equipment for return to user will emphasize support or operational readiness requirements. Authorized maintenance includes replacement and repair of modules/components and end items which can be accomplished efficiently with available skills, tools, and equipment. Establishes the Direct Exchange (DX) program for AVUM units by repairing selected items for return to stock when such repairs cannot be accomplished at the AVUM level. Inspects, troubleshoots, tests, diagnoses, repairs, adjusts, calibrates, and aligns system modules/components. Module/component disassembly and repair will support the DX program and will normally be limited to tasks requiring cleaning and the replacement of seals, fittings and items of common hardware. Unserviceable repairable modules/components and end items which are beyond the capability of AVIM to repair will be evacuated to Depot Maintenance. This level will perform special inspections which exceed AVUM capability. Provides quick response maintenance support, on-the-job training, and technical assistance through the use of mobile maintenance contact teams. Maintenance authorized operational readiness float. Provides collections and classification services for serviceable/unserviceable material. Operates a cannibalization activity in accordance with AR 750-50.

(3) At AVIM level, complex electronic repair and testing are performed by Calibration Repair Center (CRC) personnel of The Army TMDE Support Team (ATST).

B-2. Use of the Maintenance Allocation Chart.

a. The MAC assigns maintenance functions to the lowest level of maintenance based on past experience and the following considerations:

- (1) Skills available.
- (2) Time required.
- (3) Tools and test equipment required and/or available.

b. Only the lowest level of maintenance authorized to perform a maintenance function is indicated. If the lowest level of maintenance cannot perform all tasks of any single maintenance function (e.g., test, repair), then the higher maintenance level(s) that can accomplish additional tasks will also be indicated.

c. A maintenance function assigned to a maintenance level will automatically be authorized to be performed at any higher maintenance level.

d. A maintenance function that cannot be performed at the assigned level of maintenance for any reason may be evacuated to the next higher maintenance organization. Higher maintenance levels will perform the maintenance functions of lower maintenance levels when required or directed by the appropriate commander.

e. The assignment of a maintenance function will not be construed as authorization to carry the associated repair parts in stock. Authority to requisition, stock, or otherwise secure necessary repair parts will be as specified in the repair parts and special tools list appendix.

f. Normally there will be no deviation from the assigned level of maintenance. In cases of operational necessity, maintenance functions assigned to a maintenance level may, on a one-time basis and at the request of the lower maintenance level, be specifically authorized by the maintenance officer to the level of maintenance to which the function is assigned. The special tools, equipment, etc., required by the lower level of maintenance to perform this function will be furnished by the maintenance level to which the function is assigned. This transfer of a maintenance function to a lower maintenance level does not relieve the higher maintenance level of the responsibility of the function. The higher level of maintenance has the authority to determine:

- (1) If the lower level is capable of performing the work.
- (2) If the lower level will require assistance or technical supervision and on-site inspection.
- (3) If the authorization will be granted.

g. Organizational through depot maintenance of the equipment will be performed by designated ATCOM personnel.

h. Changes to the MAC will be based on continuing evaluation and analysis by responsible technical personnel and on reports received from field activities.

B-3. Definitions.

a. *Inspect.* To determine serviceability of an item by comparing its physical, mechanical and electrical characteristics with established standards.

b. *Test.* To verify serviceability and detect incipient failure by measuring the mechanical or electrical characteristics of an item and comparing those characteristics with prescribed standards.

c. *Service.* To clean, to preserve, to charge, and to add fuel, lubricants, cooling agents and air.

d. Adjust. To rectify to the extent necessary to bring into proper operating range.

e. Align. To adjust specified variable elements of an item to bring to optimum performance.

f. Calibrate. To determine the corrections to be made in the readings of instruments or test equipment used in precise measurement. Consists of the comparison of two instruments, one of which is a certified standard of known accuracy, to detect and adjust any discrepancy in the accuracy of the instrument or test equipment being compared with the certified standard.

g. Install. To set up for use in an operational environment such as an emplacement, site or vehicle.

h. Replace. To replace unserviceable items with serviceable assemblies, subassemblies or parts.

i. Repair. To restore an item to serviceable condition through correction of a specific failure or unserviceable condition. This includes, but is not limited to, inspection, cleaning, preserving, adjusting, replacing, welding, riveting, and strengthening.

j. Overhaul. To restore an item to a completely serviceable condition as prescribed by maintenance serviceability standards prepared and published for the specific item to be overhauled.

k. Rebuild. To restore an item to a standard as nearly as possible to the original or new condition in appearance, performance, and life expectancy. This is accomplished through the maintenance technique of complete disassembly of the item, inspection of all parts or components, repair or replacement of worn or unserviceable elements (items) using original manufacturing tolerances and specifications, and subsequent reassembly of the item.

B-4. Functional Groups. Group numbers correspond to the breakdowns in Repair Parts and Special Tools List (RPSTL) TM 55-4920-429-23P.

B-5. Maintenance Categories and Work Times. The maintenance categories (levels) AVUM, AVIM, and DEPOT are listed on the Maintenance Allocation Chart with individual columns that indicate the work times for maintenance functions at each maintenance level. Work time presentations such as 0.1 indicate the average time it requires a maintenance level to perform a specified maintenance function. If a work time has not been established, the columnar presentation shall indicate "-.-". Maintenance levels higher than the level of maintenance indicated are authorized to perform the indicated function.

B-6. Tools and Test Equipment (Section III). Common tool sets (not individual tools), special tools, test and support equipment required to perform maintenance functions are listed alphabetically with a reference number to permit cross-referencing to column 5 in the MAC. In addition, the maintenance category authorized to use the device is listed along with the item National Stock Number (NSN) and, if applicable, the tool number to aid in identifying the tool/device.

SECTION II MAINTENANCE ALLOCATION CHART

NOMENCLATURE OF END ITEMS
AFCS LINE TEST SET 145 G009-1

(1) Group Number	(2) Component/Assembly	(3) Maintenance Function	(4) Maintenance Category			(5) Tools and Equipment	(6) Remarks
			AVUM	AVIM	DEPOT		
01	AFCS LINE TEST SET						
02	CABLE ASSEMBLIES						
0201	Cable Assemblies	Inspect Test Replace Repair	— . — — . — — . — — . —			6,2	
03	PANEL ASSEMBLY						
0301	Panel Assembly"	Inspect Repair	— . — — . —	— . — *		6,7	
0302	Power Supplies	Inspect Test Adjust Replace Repair	— . — — . — — . — — . — — . —	— . — * — . — * — . — *	— . —	1,2,3,7	
0303	Terminal Boards and Circuit Card Assemblies	Inspect Test Adjust Replace Calibrate Repair	— . — — . — — . — — . — — . — — . —	— . — * — . — * — . — * — . — * — . — *	— . —	1,2,3,4,5, 7,8	
0304	Meter, Digital, Analog and Elapsed Time	I n s p e c t Test Adjust Replace Calibrate Repair	— . — — . — — . — — . — — . — — . —	— . — * — . — * — . — * — . — *	— . —	1,3,5,7	
0305	Switches, Potentiometers, and Circuit Breakers	Inspect Test Replace	— . — — . — — . —	— . — *		3,7	
0306	Lamps and Light Light Assemblies	Inspect Test Replace	— . — — . — — . —	— . — *		3,7	
0307	Miscellaneous Components (Knobs, Handles, etc.)	Inspect Replace	— . — — . —			5.6	

*Maintenance Performed by CRC Personnel

SECTION III TOOL AND TEST EQUIPMENT REQUIREMENTS
 FOR
 AFCS LINE TEST SET 145 G0009-1

TOOL OR TEST EQUIPMENT REF CODE	MAINTENANCE CATEGORY	NOMENCLATURE	NATIONAL/NATO STOCK NUMBER	TOOL NUMBER
1	F	AC Power Supply '400 Hz, NH Research SF613-1 or equal		
2	F	Oscilloscope, Tektronix 5440 W/ plug in 5S-14N or equal		
3	F	Digital Multimeter, Fluke 8800A or equal		
4	F	Decade Resistor, Biddle Gray 6011471 or equal		
5	F	DC Power Supply 0-36 Volt NJE CS36CR30 or equal		
6	F	Tool Kit, Electronic Equipment TK-100/G	5180-00-605-0079	
7	O	Tool Kit, Electronic Equipment TK-101/G	5180-00-064-5178	
8	F	Test Aid (fig. 4-3)		

ALPHABETICAL INDEX

	Para	Page
A		
AC/DC Amplifier		
Testing	4-31	4-13
Theory	1-14	1-6
Troubleshooting	4-6	FO-21
AC to DC Converter		
Testing	4-31	4-13
Theory	1-15	1-6
Troubleshooting	4-6	FO-21
Actuator Drive Circuit		
Testing	4-35	4-25
Theory	1-23	1-10
Troubleshooting	4-10	FO-21
Adjustments		
Analog Meter	4-23	4-6
Dc Power Supply	4-23	4-6
AFCS ANN Circuit		
Testing	4-36	4-27
Theory	1-19	1-7
Troubleshooting	4-11	FO-21
Amplifiers		
Ac/Dc	1-14	1-6
Offset/Inverter	1-16	1-6
Programmable Gain	1-17	1-6
Valve Drive	1-23	1-10
Analog Meter		
Adjustment	4-23	4-6
Replacement	4-23	4-6
B		
Block Diagram	1-12	1-5
C		
Circuit Breaker		
Replacement	4-19	4-5
Testing	4-38	4-27
Troubleshooting	4-3	FO-9
Cleaning		
Exterior	3-3	3-1
Interior	4-18	4-4

	Para	Page
Connectors		
Repair	3-7	3-2
Replacement	4-20	4-5
Controls and Indicators	2-2	2-3
Converter, Ac to Dc— See Ac to Dc Converter		
CPT Monitor		
Testing	4-34	4-22
Theory	1-24	1-13
Troubleshooting	4-9	FO-21
D		
Dash Pre-Engage Circuit		
Testing	4-38	4-27
Theory	1-19	1-7
Troubleshooting	4-13	FO-21
Demodulator, Feedback Signal— See Feedback Signal Demodulator		
Description and Data	1-9	1-4
Digital Display CCA A1		
Testing	4-30	4-11
Theory	1-25	1-14
Troubleshooting	4-4	FO-12
Digital Multimeter CCA A2		
Testing	4-30	4-11
Replacement	4-20	4-5
Troubleshooting	4-5	FO-20
Disassembly	4-17	4-3
Discrete Signal Monitor Circuit		
Test	4-31	4-13
Theory	1-13	1-5
Troubleshooting	4-6	FO-21
Dc Power Supply		
Adjustment	4-23	4-6
Replacement	4-21	4-5
Testing	4-29	4-10
Troubleshooting	4-4	FO-12

E

Extensible Link Servo-Control Circuit		
Testing	4-32	4-16
Theory	1-20	1-9
Troubleshooting	4-7	FO-21

F

Feedback Signal Demodulator		
Testing	4-35	4-25
Theory	1-22	1-10
Troubleshooting	4-10	FO-21
Furnished Items	1-10	1-4

G

Generator, Square Wave— See Square Wave Generator		
Gyro Test Circuit		
Testing	4-33	4-20
Theory	1-19	1-7
Troubleshooting	4 - 8	F O - 2 1

H

HDG SEL Enable Circuit		
Testing	4-37	4-27
Theory	1-19	1-7
Troubleshooting	9-12	FO-14

I

ILCA Drive Circuit Testing		
Testing	4-32	4-16
Theory	1-20	1-9
Troubleshooting	4-7	FO-21
Indicators		
Testing	4-29	4-10
Replacement	4-20	4-5
Troubleshooting	4-3	FO-9
Inspection	4-16	4-3
Installation of Panel	4-24	4-8
Inverter/Amplifier See Programmable Inverter Amplifier		
Items Furnished	1-10	1-4

J

(Not Applicable)

K

K-Ohms Range Testing		
Testing	4-30	4-11
Theory	1-24	1-13
Troubleshooting	4-4	FO-12
Knob		
Replacement	3-5	3-2

L

Lamp		
Replacement	3-6	3-2
Testing	4-29	4-10
Lens		
Replacement	3-6	3-2

M

Meter — See Analog Meter		
Meter Hyteresis Testing	4-30	4-11
Multimeter		
Testing	4-30	4-11
Theory	1-25	1-14
Troubleshooting	4-5	FO-20

O

Offset Inverter/Amplifier		
Testing	4-31	4-13
Theory	1-17	1-6
Troubleshooting	4-6	FO-21
Operating Instruction	2-1	2-1
Operational Start Up	2-5	2-15

P

Painting, TouchUp	3-4	3-1
Panel Component Replacement	4-20	4-5
Panel Installation	4-25	4-9
Panel Removal	4-15	4-3
Power Supply		
Adjustment	4-23	4-6
Replacement	4-21	4-5
Testing	4-28	4-9
Troubleshooting	4-3	FO-9
Power Circuit and Power Transistor		
Testing	4-28	4-9
Theory	1-24	1-13
Troubleshooting	4-3	FO-9
Preventive Maintenance	2-3	2-11
Preliminary Procedures	4-28	4-9
Programmable-Gain Amplifier		
Testing	4-31	4-13
Theory	1-16	1-6
Troubleshooting	4-6	FO-21
Preventive Maintenance Checks and Services Chart	3-9	3-6

Q
(Not Applicable)

R

Relay		
Replacement	4-20	4-5
Repair		
Connector	3-7	3-2
Cable	3-7	3-2
Replacement		
Circuit Breaker	4-20	4-5
Circuit Card	4-19	4-5
Connector	4-20	4-5
Digital Multimeter	4-20	4-5
Indicator	4-20	4-5
Lamp	3-6	3-2
Lens	3-6	3-2
Knob	3-5	3-2
Power Supply	4-21	4-5
Relay	4-20	4-5
Resistor	4-20	4-5
Switch	4-20	4-5
Transformer	4-21	4-5
Resistor		
Replacement	4-20	4-5

S

Self Test and Power Supply Circuit		
Testing	4-29	4-10
Theory	1-24	1-13
Troubleshooting	4-4	FO-12
Servicing	3-2	3-1
Square Wave Generator		
Testing	4-32	4-7
Theory	1-21	1-10
Troubleshooting	4-7	FO-21
Switch		
Replacement.	4-20	4-5

T

Test Equipment Required, Testing	4-27	4-9
Test Equipment Required, Troubleshooting	4-2	4-1

	Para	Page
Testing		
Actuator Drive Circuit	4-35	4-25
AFC SANN Circuit	4-36	4-27
Cpt Monitor Check	4-34	4-22
Dash Pre-Engage Circuit	4-38	4-27
Discrete Signal Monitor Circuit	4-31	4-13
Gyro Test	4-33	4-20
HDGSEL Engage	4-37	4-27
ILCA Drive Circuit	4-32	4-17
Multimeter Circuit	4-30	4-11
Power Circuits and Power Indicator	4-28	4-9
Self Test and Power Supply	4-29	4-10
Theory		
AC/DC Amplifier	1-14	1-6
AC/DC Converter	1-15	1-6
Block Diagram	1-12	1-5
Digital Display CCA A1	1-24	1-13
Digital Multimeter CCA A2	1-25	1-14
Discrete Signal Monitor Circuit	1-13	1-5
Discrete Signal Monitor Program	1-19	1-7
Extensible Link Servo Control	1-20	1-9
Feedback Signal Demodulator	1-22	1-10
Offset Inverter Amplifier	1-17	1-6
Programmable-Gain Amplifier	1-16	1-6
Square Wave Generator	1-21	1-10
Threshold Detector	1-18	1-7
Valve-Drive Amplifier	1-23	1-10
Touch-Up Painting	3-4	3-1
Transformer		
Replacement	4-21	4-5
Troubleshooting		
Actuator Drive Circuit	4-10	FO-21
AFCS ANN Circuit	4-11	FO-21
CPT Monitor Circuit	4-9	FO-21
DASH Pre-Engage Circuit	4-13	FO-21
Discrete Signal Monitor Circuit	4-6	FO-21
Gyro Test	4-8	FO-21
HDG SEL Engage	4-12	FO-21
ILCA Drive Circuit	4-7	FO-21
Multimeter Circuit	4-5	FO-20
Power Circuits and Power Indicator	4-3	FO-9
Self Test and Power Supply	4-4	FO-12
u		
Unpacking	2-1	2-1

V

VAC Range Test	4-30	4-12
Valve-Drive Amplifier		
Testing	4-31	4-13
Theory	1-22	1-10
Troubleshooting	4-7	FO-21
VDC Range Test	4-30	4-11

W-X-Y-Z
(Not applicable)

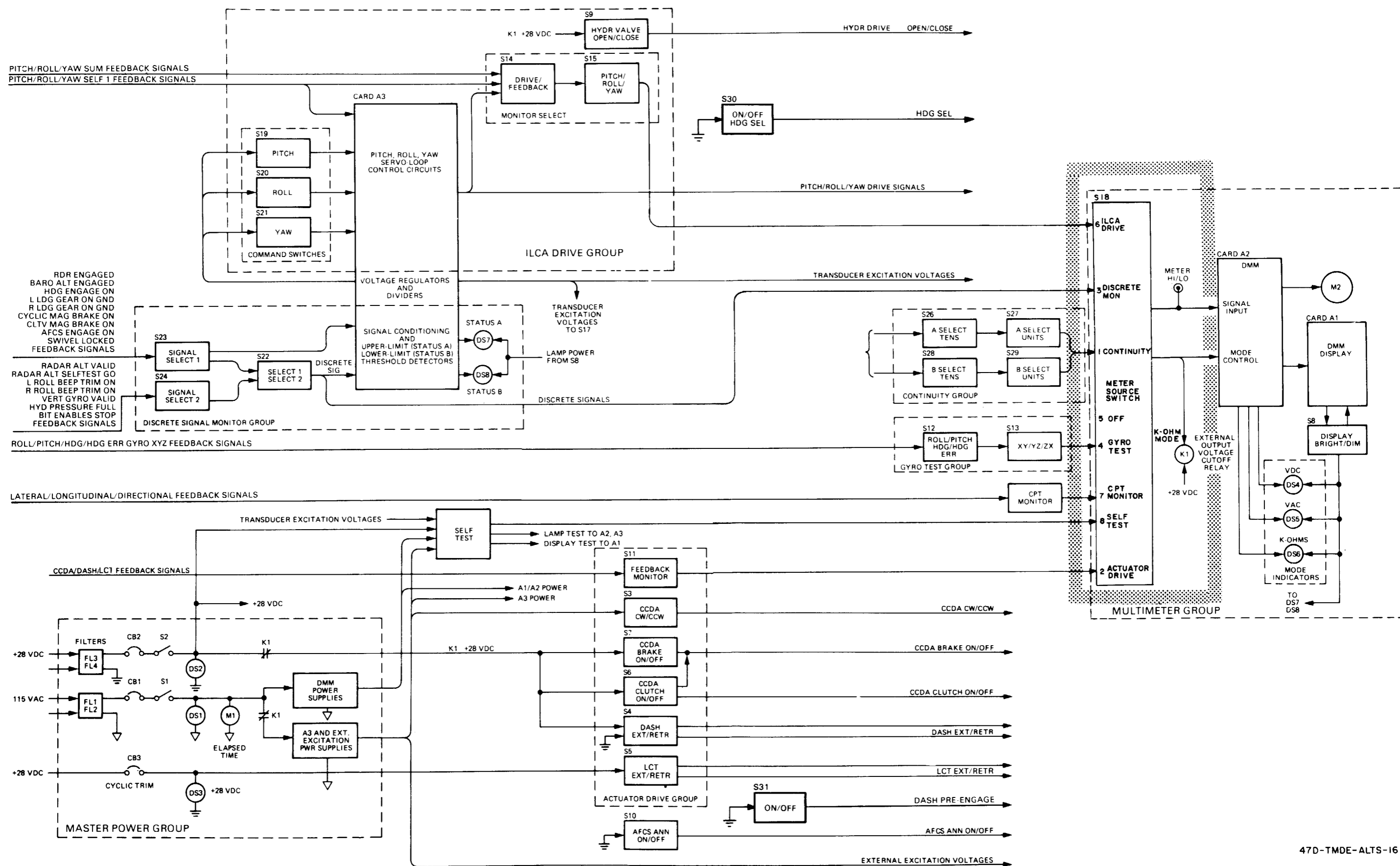

FO-1. A FCS Line Test Set Block Diagram

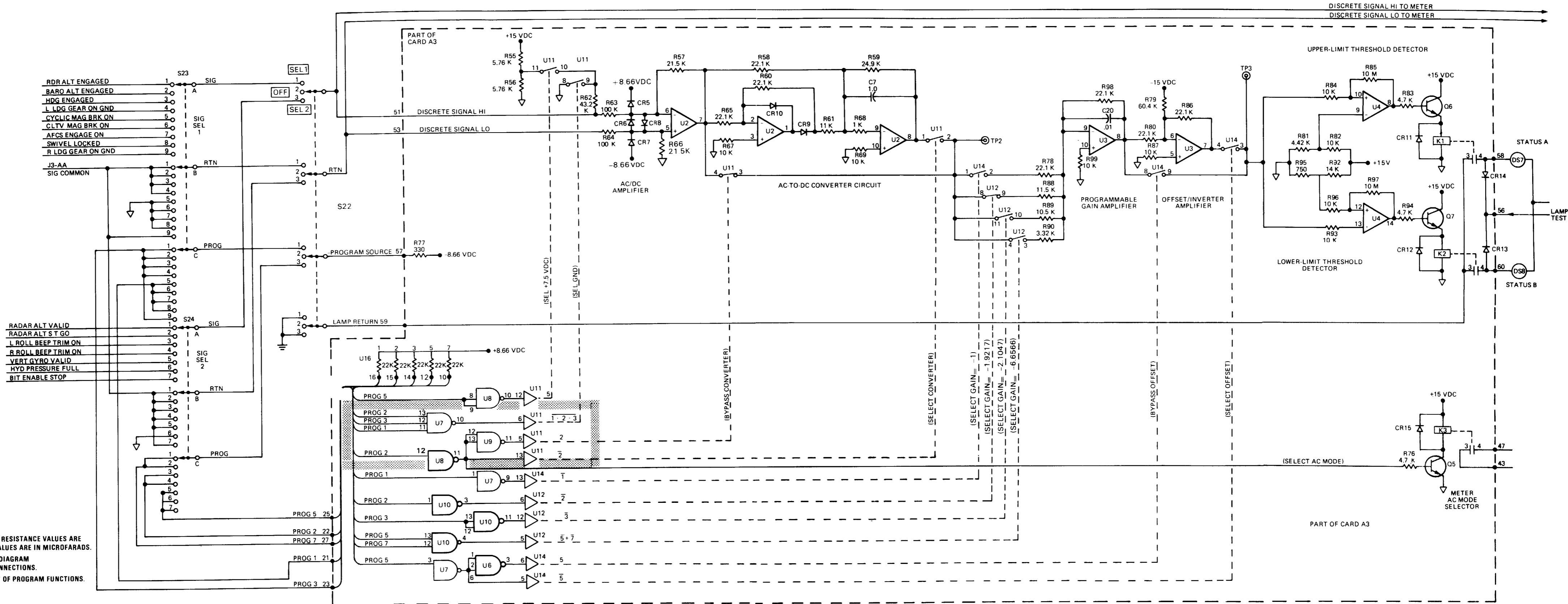

- NOTES**
1. UNLESS OTHERWISE SPECIFIED, RESISTANCE VALUES ARE IN OHMS AND CAPACITANCE VALUES ARE IN MICROFARADS.
 2. REFER TO SYSTEM SCHEMATIC DIAGRAM FOR VOLTAGE AND GROUND CONNECTIONS.
 3. SEE TABLE 1-2 FOR A SUMMARY OF PROGRAM FUNCTIONS.

FO-2. Discrete Signal Monitor Circuits Simplified Schematic Diagram

PART OF CARD A3

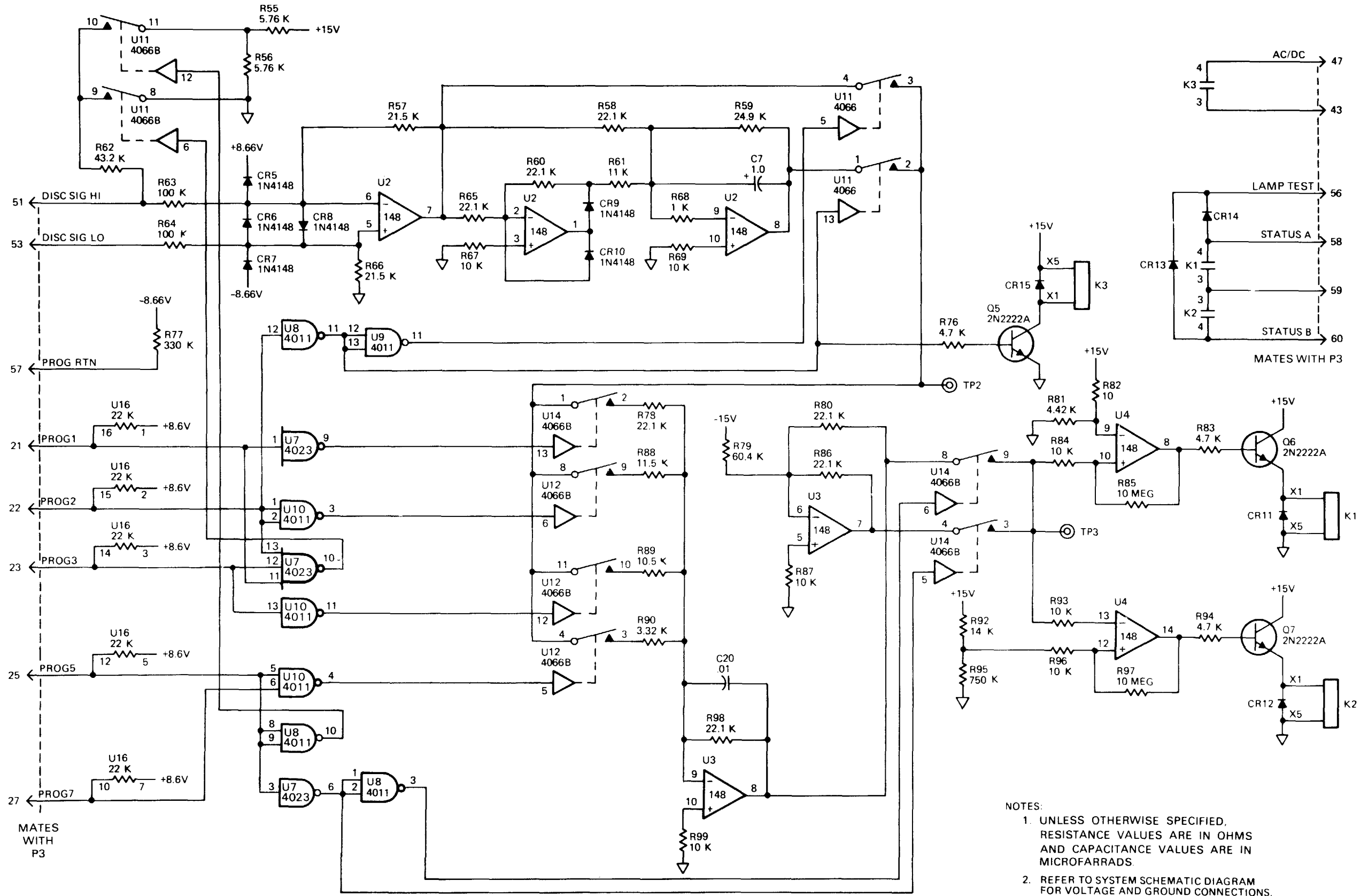

- NOTES:
1. UNLESS OTHERWISE SPECIFIED, RESISTANCE VALUES ARE IN OHMS AND CAPACITANCE VALUES ARE IN MICROFARRADS.
 2. REFER TO SYSTEM SCHEMATIC DIAGRAM FOR VOLTAGE AND GROUND CONNECTIONS.

FO-3. Discrete Signal Monitor Detailed Schematic Diagram

Table 1-2. Summary of Programmed Normalizing Functions, Signal Levels, and Status Indicator Conditions

PROGRAM	TEST FUNCTION	FEEDBACK SIGNAL LEVELS	PROGRAMMED SUBSTITUTE INPUT	AC/DC AMP. OUTPUT GAIN		AC-TO-DC CONVERTER OUTPUT	PROGRAMMABLE-GAIN AMP. OUTPUT PROGRAMMED GAIN				OFFSET/ INVERTER OUTPUT	THRESHOLD DETECTOR INPUT	STATUS INDICATOR CONDITIONS	
				-0.215	-0.150		-1.00	-1.9217	-2.1047	-6.6566			A	B
1	CYCLIC MAG BRAKE, CLTV MAG BRAKE, SWIVEL LOCK, AFCS ENGAGE, (28vdc or open)	1) +28.0	-6.02	+6.02	+6.02	ON	OFF
		2) +21.5	-4.62	+4.62	+4.62	ON	OFF
		3) +20.0	-4.30	+4.30	+4.30	OFF	OFF
		4) + 3.6	-0.77	+0.77	+0.77	OFF	OFF
		5) + 3.5	-0.75	+0.75	+0.75	OFF	ON
		6) Open	Logic Gnd	0	0	0	OFF	ON
2	L ROLL BEEP TRIM, R ROLL BEEP TRIM, G=0.4168	1) 13.00 Vac	2.795 Vac	-2.795	+5.37	+5.37	ON	OFF
		2) 11.25 Vac	2.418 Vac	-2.418	+4.64	+4.64	ON	OFF
		3) 11.00 Vac	2.365 Vac	-2.365	+4.54	+4.54	OFF	OFF
		4) 1.90 Vac	0.409 Vac	-0.409	+0.78	+0.78	OFF	OFF
		5) 1.80 Vac	0.387 Vac	-0.387	+0.74	+0.74	OFF	ON
		6) Open	Logic Gnd	0	0	0	0	OFF	ON
3	L & R LDG GEAR ON GND, HEADING ENGAGE, BARO ALT ENGAGE, RADAR ALT ENGAGE, G=0.4525	1) +12.00	-2.58	+5.43	+5.43	ON	OFF
		2) +11.25	-2.20	+4.85	+4.85	ON	OFF
		3) +11.00	-2.15	+4.52	+4.52	OFF	OFF
		4) + 1.70	-0.36	+0.77	+0.77	OFF	OFF
		5) + 1.60	-0.34	+0.72	+0.72	OFF	ON
		6) Open	Logic Gnd	0	0	0	OFF	ON
5	BIT ENABLE STOP VERT GYRO VALID HYDR PRESSURE FULL	1) Gnd	0	0	+5.48	+5.48	ON	OFF
		2) NA
		3) NA
		4) NA
		5) NA
		6) Open	+7.5	-1.125	+7.48	-2.00	-2.00	OFF
7	RADAR ALT SELF TEST RADAR ALT VALID	1) + 4.50	-0.9675	+6.439	+6.439	ON	OFF
		2) + 3.25	-0.6987	+4.650	+4.650	ON	OFF
		3) + 3.20	-0.6880	+4.579	+4.579	OFF	OFF
		4) + 0.55	-0.1180	+0.787	+0.787	OFF	OFF
		5) + 0.50	-0.1075	+0.715	+0.715	OFF	ON
		6) 0.00	0.0000	0.000	0.000	OFF	ON

Programs not listed are not used.

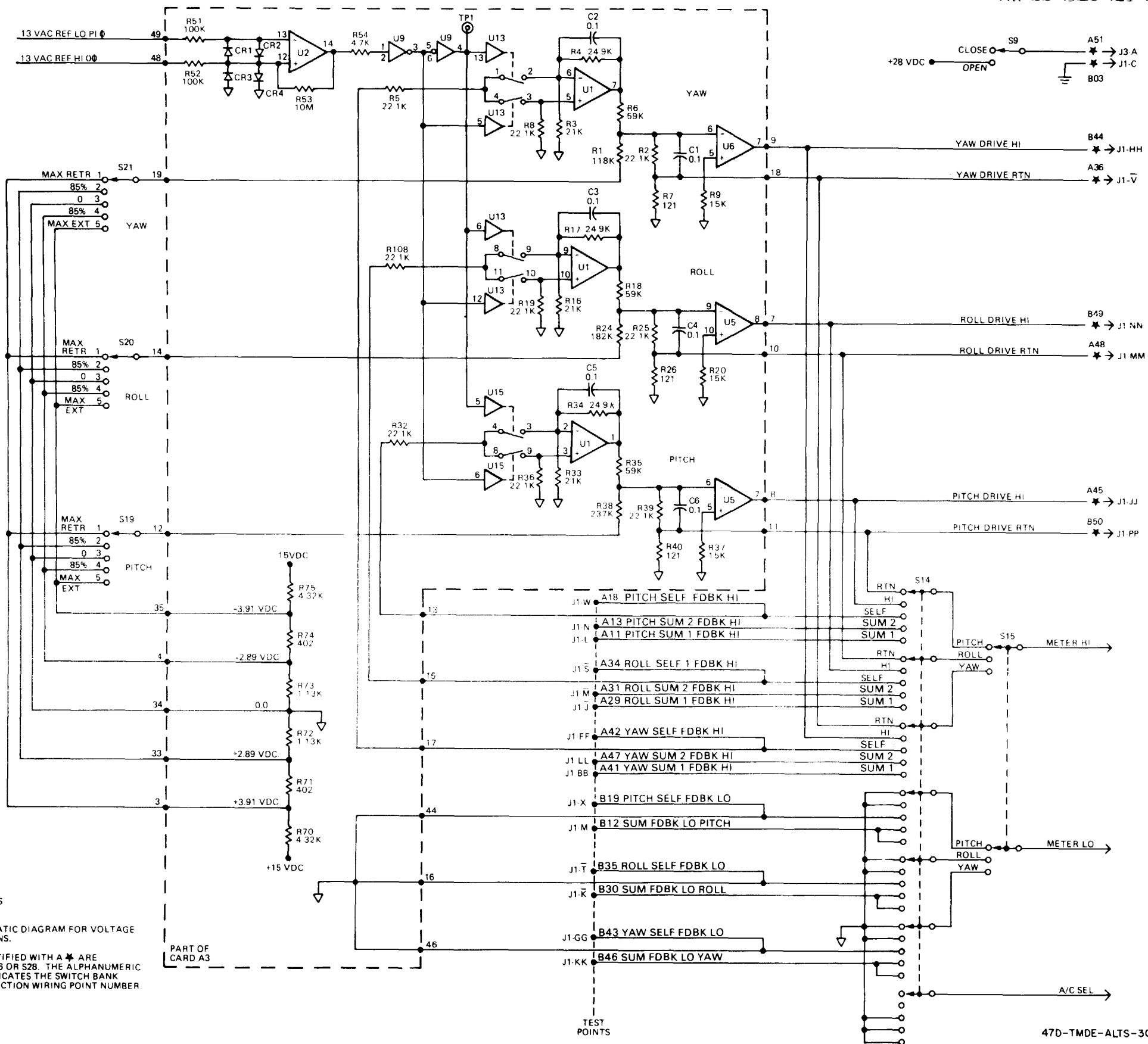

- NOTES
1. RESISTANCES ARE IN OHMS
CAPACITANCES ARE IN UF
 2. REFER TO SYSTEM SCHEMATIC DIAGRAM FOR VOLTAGE
AND GROUND CONNECTIONS.
 3. CIRCUIT LOCATIONS IDENTIFIED WITH A * ARE
CONNECTED TO SWITCH S26 OR S28. THE ALPHANUMERIC
CODE NEXT TO THE * INDICATES THE SWITCH BANK
(A OR B) AND INTERCONNECTION WIRING POINT NUMBER.

47D-TMDE-ALTS-30

FO-5. Extensible Link Servo-Control Simplified Schematic Diagram

PART OF CARD A3

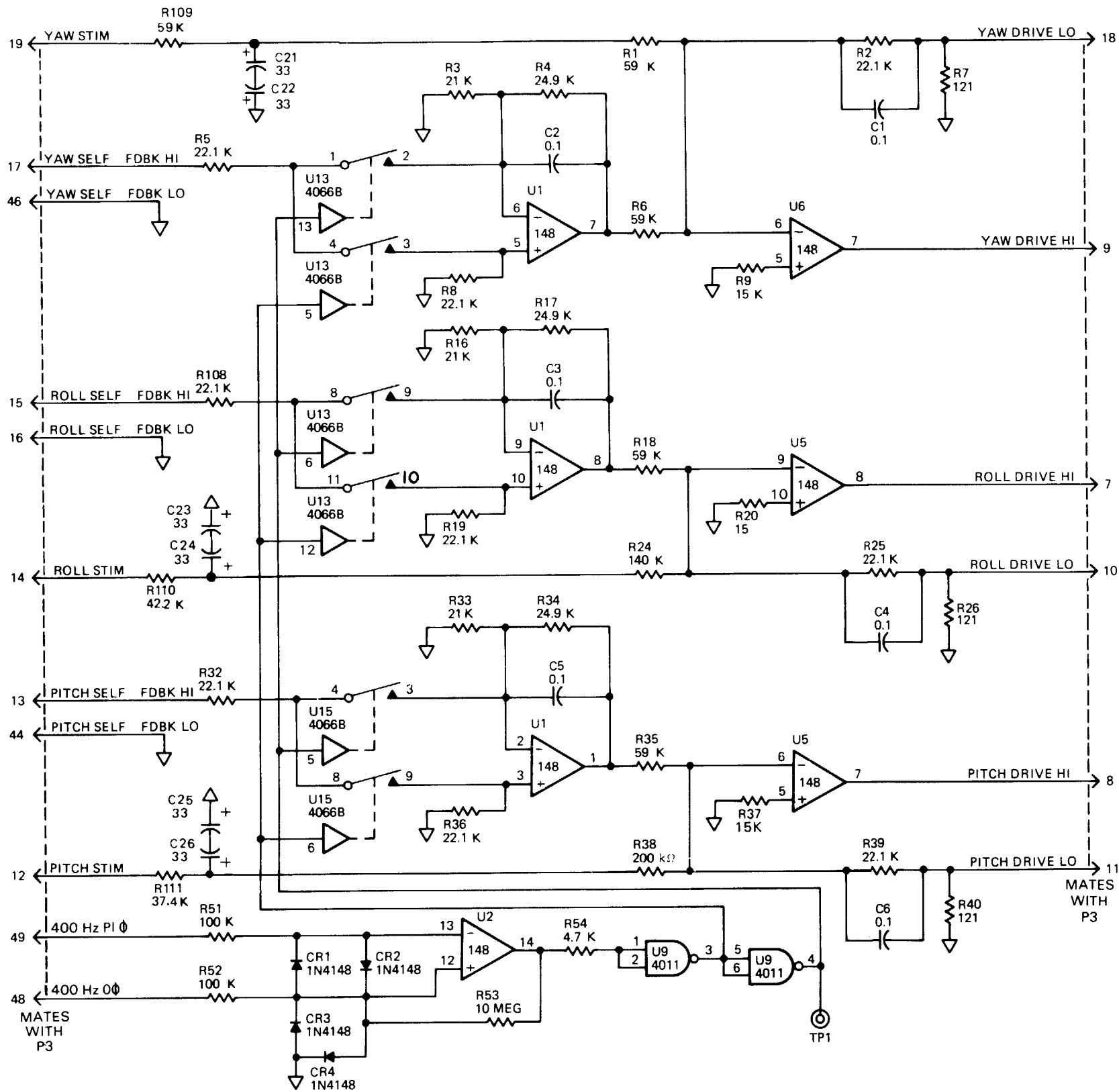

NOTE
 1. UNLESS OTHERWISE SPECIFIED, RESISTANCE VALUES ARE IN OHMS AND CAPACITANCE VALUES ARE IN MICROFARRADS.

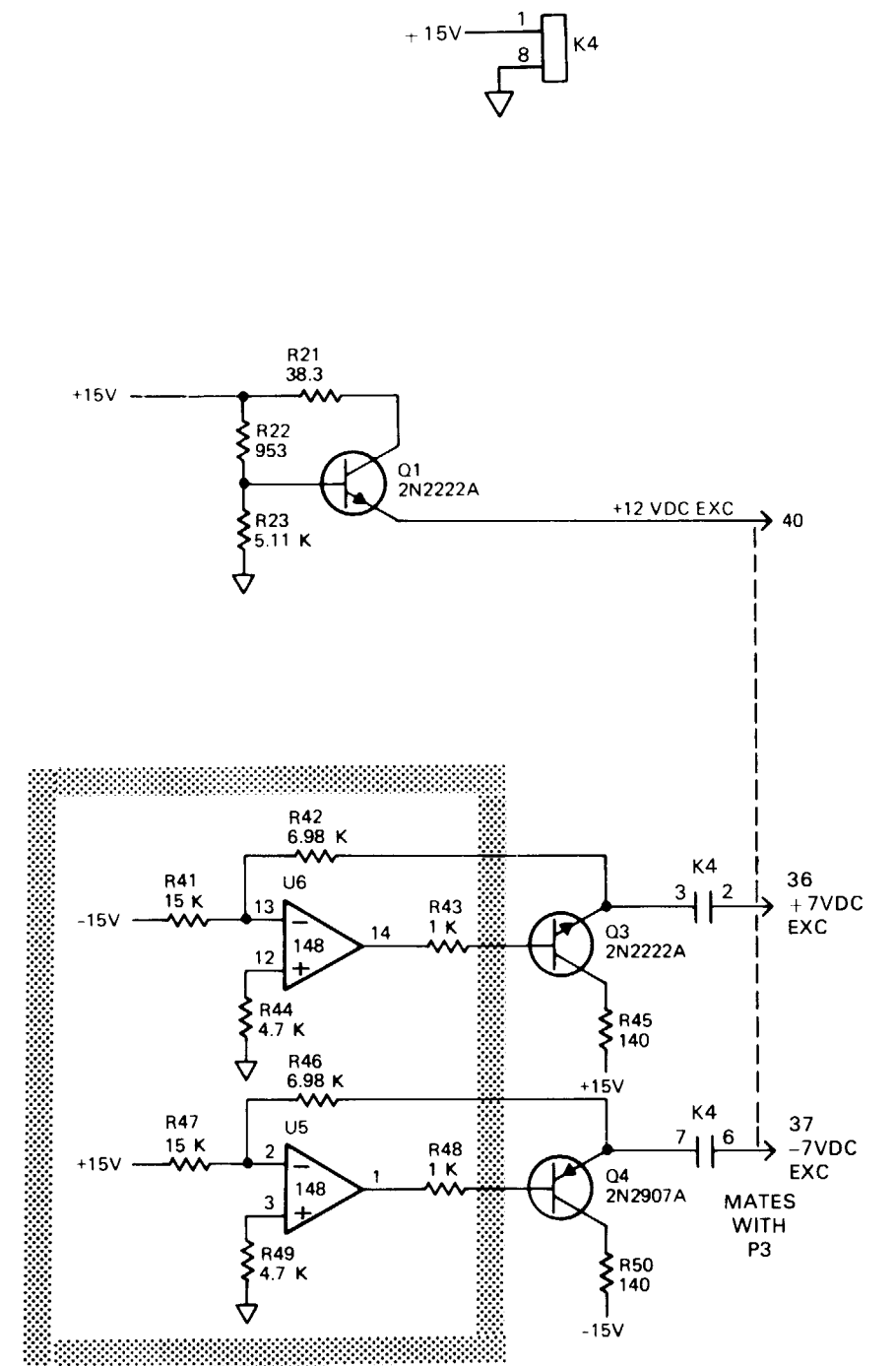

FO-6. Extensible Link Servo Loop Detailed Schematic Diagram

MICROCIRCUIT TABLE			
COMPONENTS		PINS	
REF	TYPE	PWR	GND/-V
U26,27	155	7(+15V)	4(-15V)
U14,17	5426	14(+5V)	7(VL)
U25	111	8(+15V)	4(-15V)
U7	148	4(+15V)	1(-15)
U18,22,24	5404	14(+5V)	7(VL)
U8	5410	14(+5V)	7(VL)
U4	5420	14(+5V)	7(VL)
U9	5442	16(+5V)	8(VL)
U10	5474	14(+5V)	7(VL)
U15	54157	16(+5V)	8(VL)
U5,6,11,12	54175	16(+5V)	8(VL)
U3	54193	16(+5V)	8(VL)
U20	544433	SHOWN	SHOWN
U21,23	4050	1(VDD)	8(VSS)
U19	40538	16(VDD)	7(VEE)
U16	04	14(+5V)	7(VL)

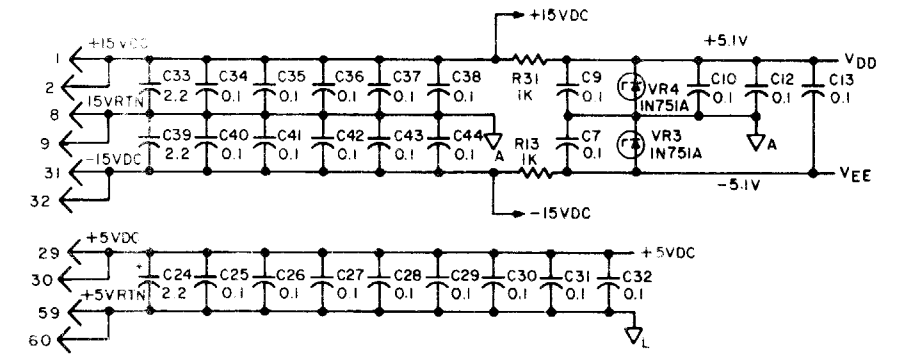
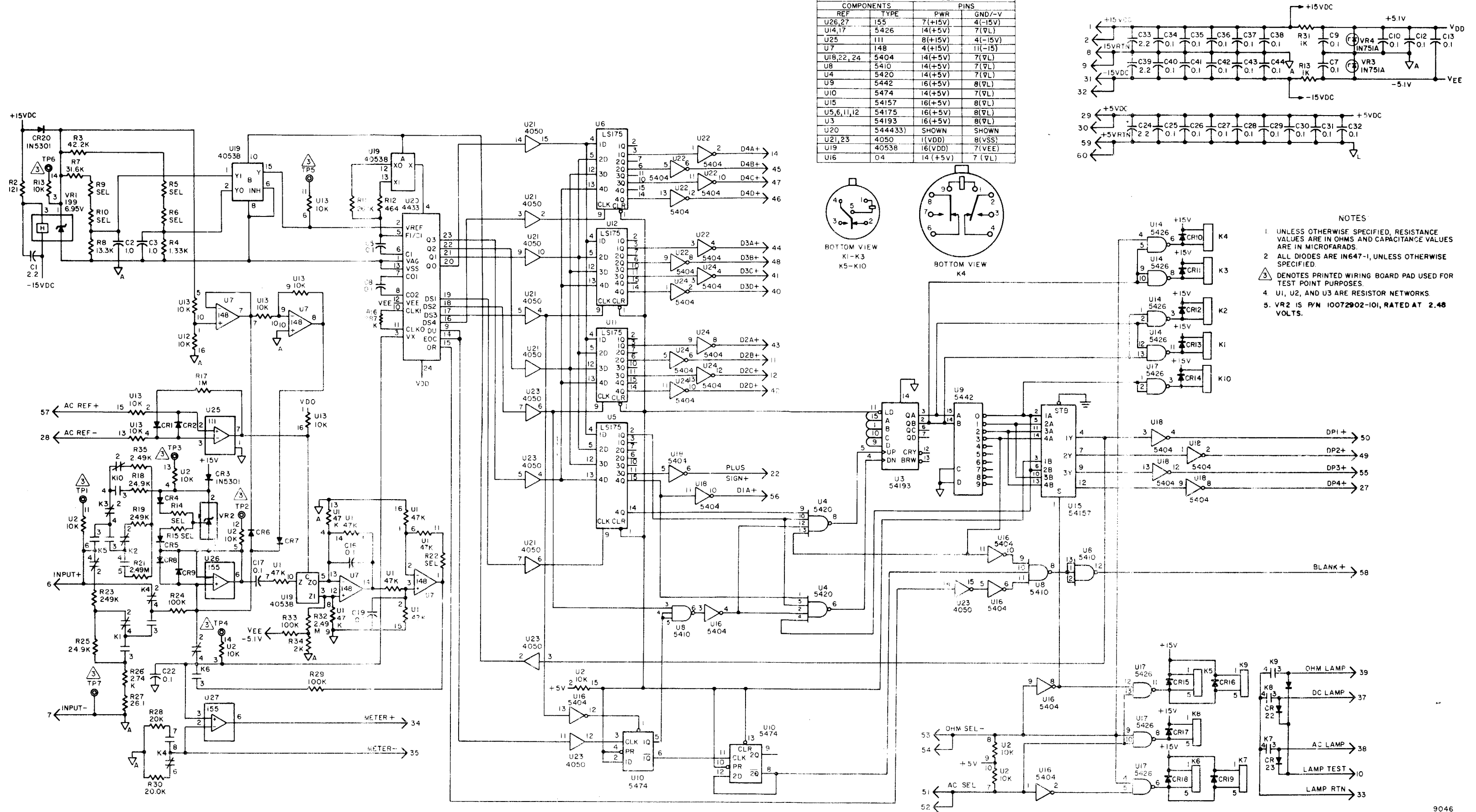
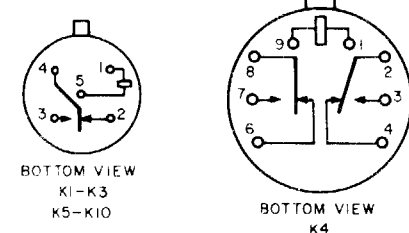

- NOTES
- UNLESS OTHERWISE SPECIFIED, RESISTANCE VALUES ARE IN OHMS AND CAPACITANCE VALUES ARE IN MICROFARADS.
 - ALL DIODES ARE IN647-1, UNLESS OTHERWISE SPECIFIED.
 - ⊠ DENOTES PRINTED WIRING BOARD PAD USED FOR TEST POINT PURPOSES.
 - U1, U2, AND U3 ARE RESISTOR NETWORKS.
 - VR2 IS P/N 10072902-101, RATED AT 2.48 VOLTS.

FO-7. Digital Multimeter Schematic Diagram

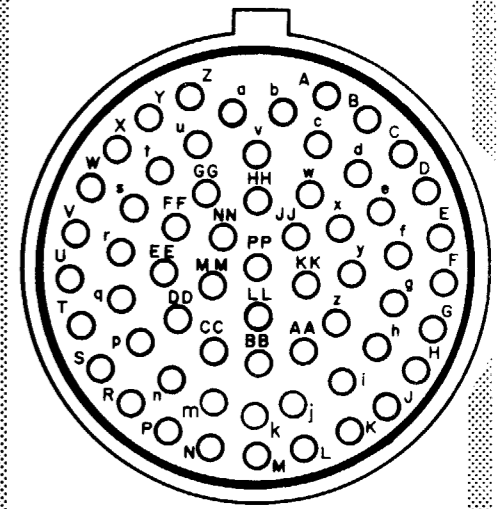
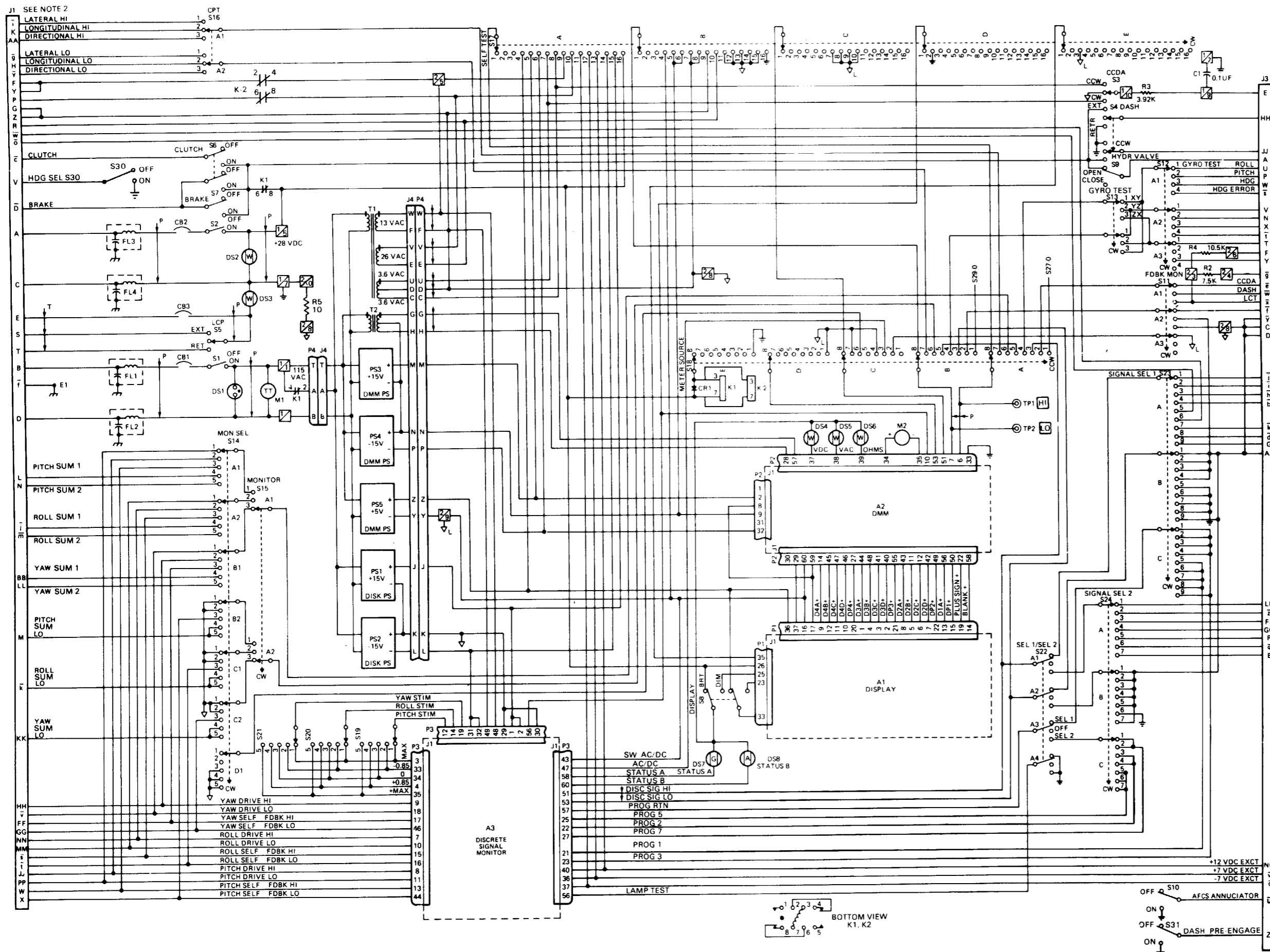

J1-MS3470L24-61P (FRONT VIEW)

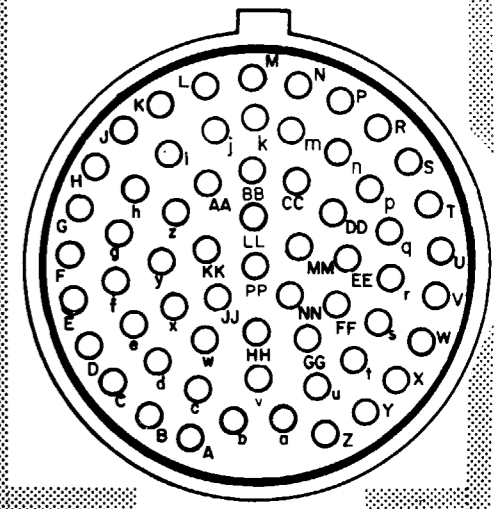

J3-MS3470L24-61PX (FRONT VIEW)

- NOTES
1. UNLESS OTHERWISE SPECIFIED, RESISTANCE VALUES ARE IN OHMS AND CAPACITANCE VALUES ARE IN MICROFARADS
 2. SEE SHEET 2 FOR J1 AND J3 INTERFACE WITH S26 AND S28
 3. S26-81 ILLUSTRATES HOW TENS AND UNITS NUMBERS ARE CODED TO TP NUMBERS
 4. WHEN THE TEST SET IS DISCONNECTED FROM EXTERNAL TEST CONNECTIONS, ALL GROUNDS IN THE TEST SET ARE NOT AT THE SAME POTENTIAL. CHASSIS GROUND IS AT RECEPTACLE PIN J1-1. DC COMMON IS AT TB1-7. AC NEUTRAL IS AT TB1-3. LOGIC GROUND IS AT TB2-8. ANALOG GROUND IS AT TP2

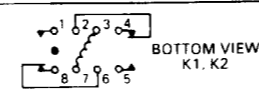

4-3. Power Circuit and Power Indicator Troubleshooting.

a. CYCLIC TRIM 28 VDC indicator does not come on.

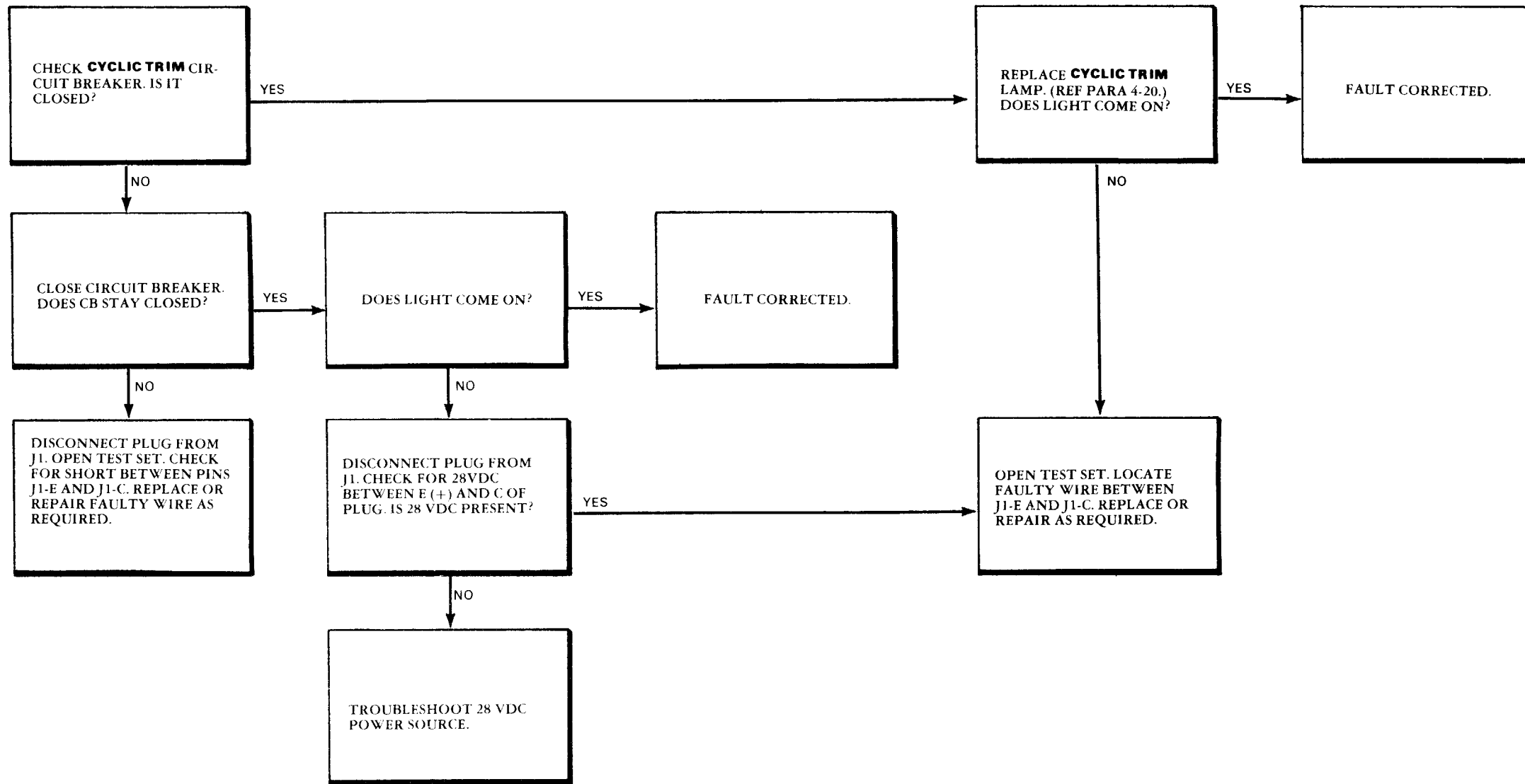

b. 115 VAC indicator does not come on with switch S1 on.

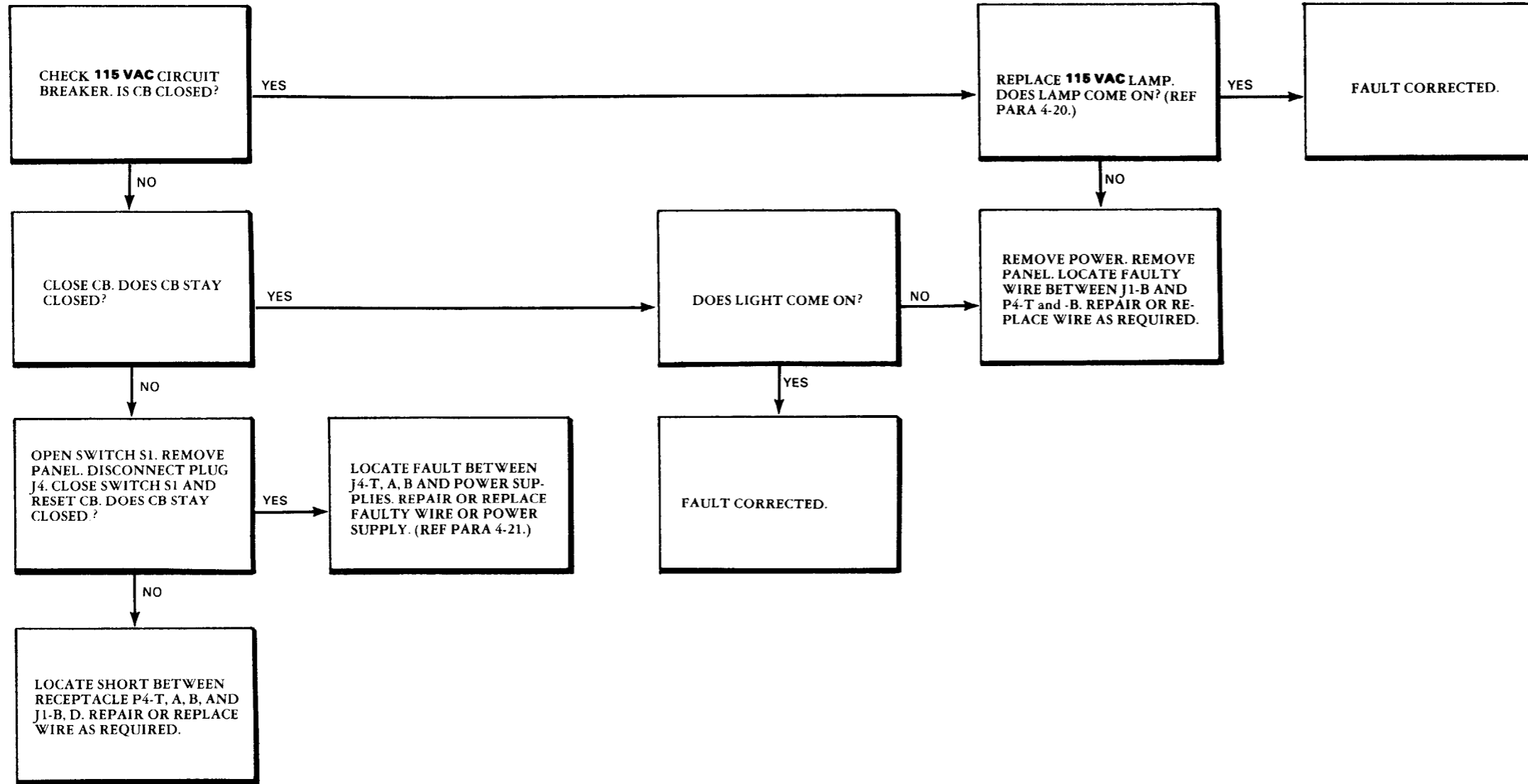

c. 28 VDC indicator will not come on during preliminary test.

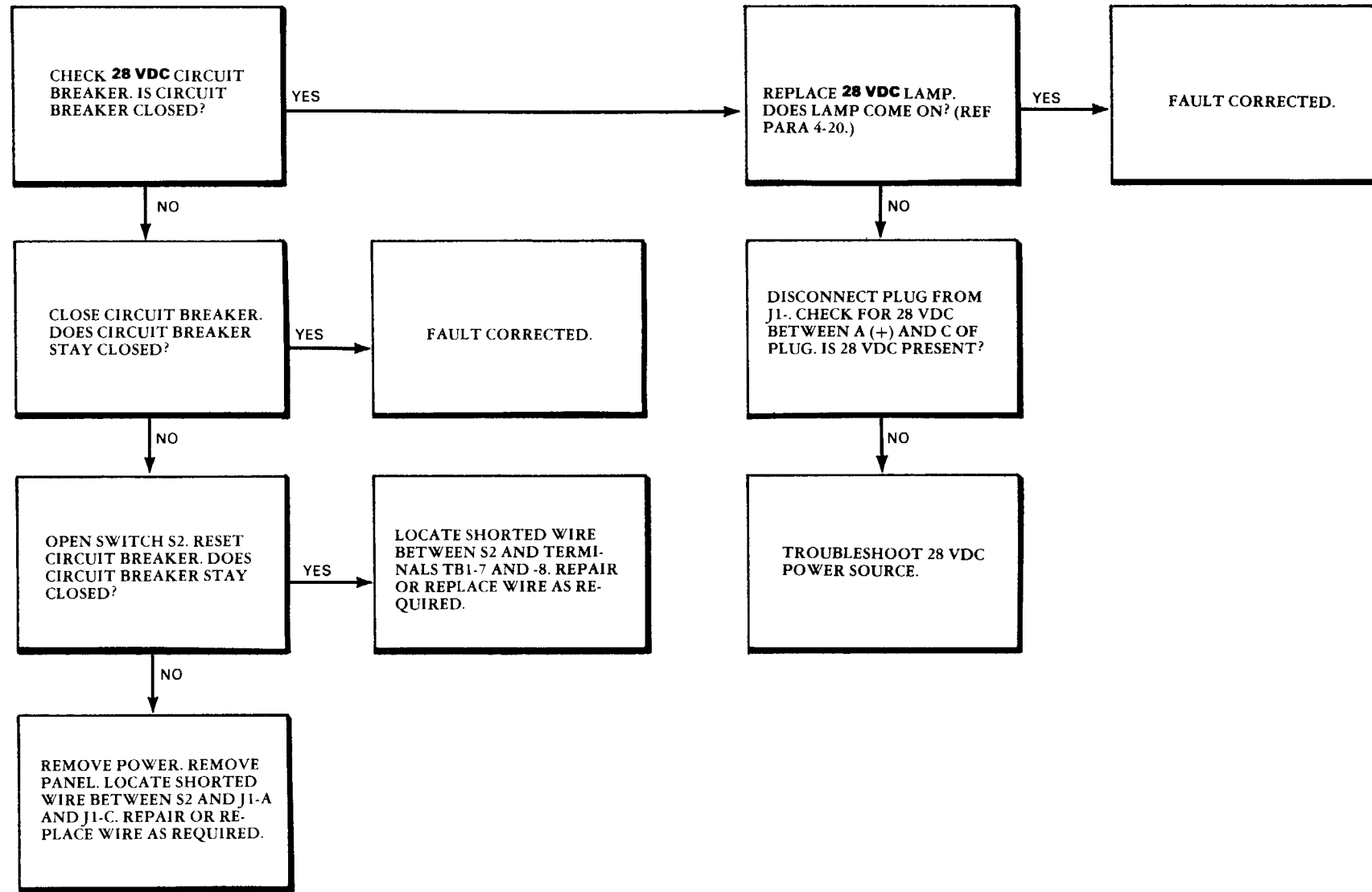

4. Self Test and Power Supply Troubleshooting.

a. Digital meter does not zero when METER SOURCE switch is set to OFF.

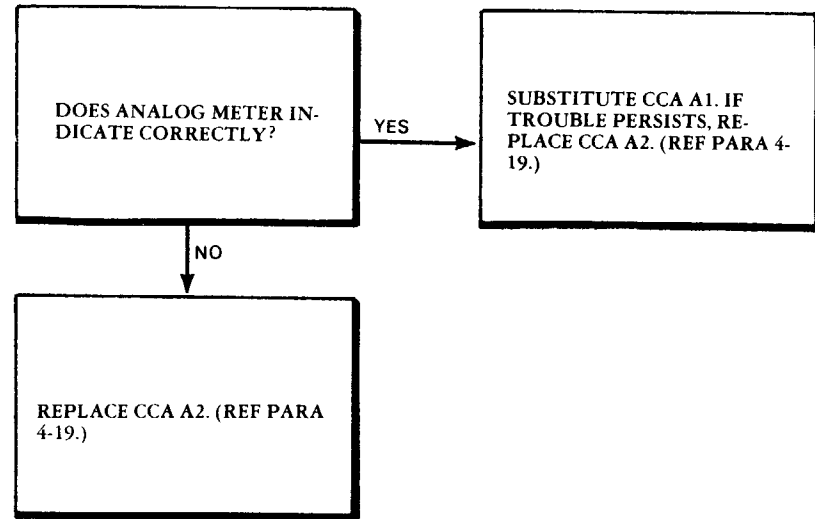

b. K-OHMS indicator does not come on when METER SOURCE switch is set to CONTINUITY.

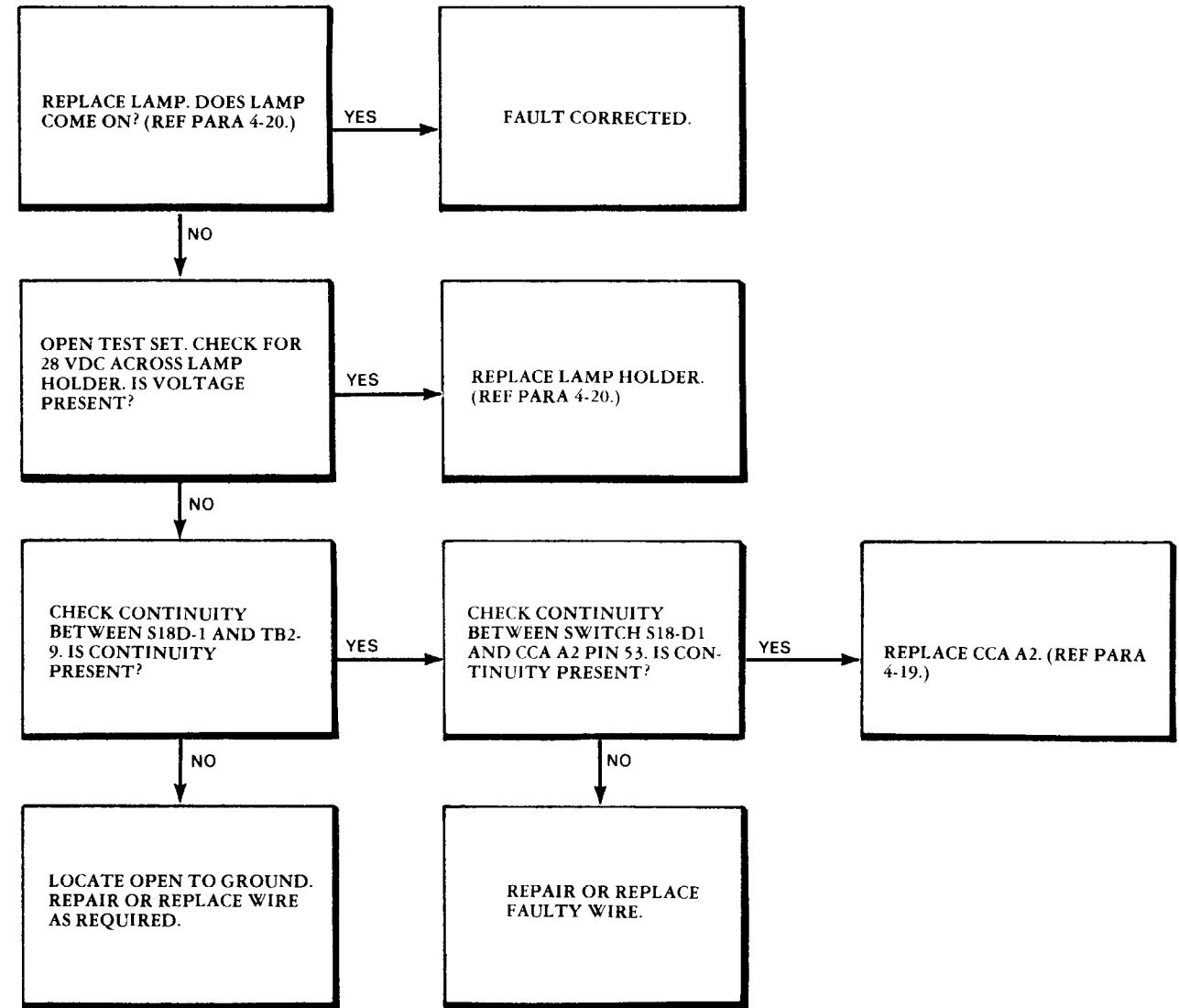

c. Digital display does not read +10 K-ohms.

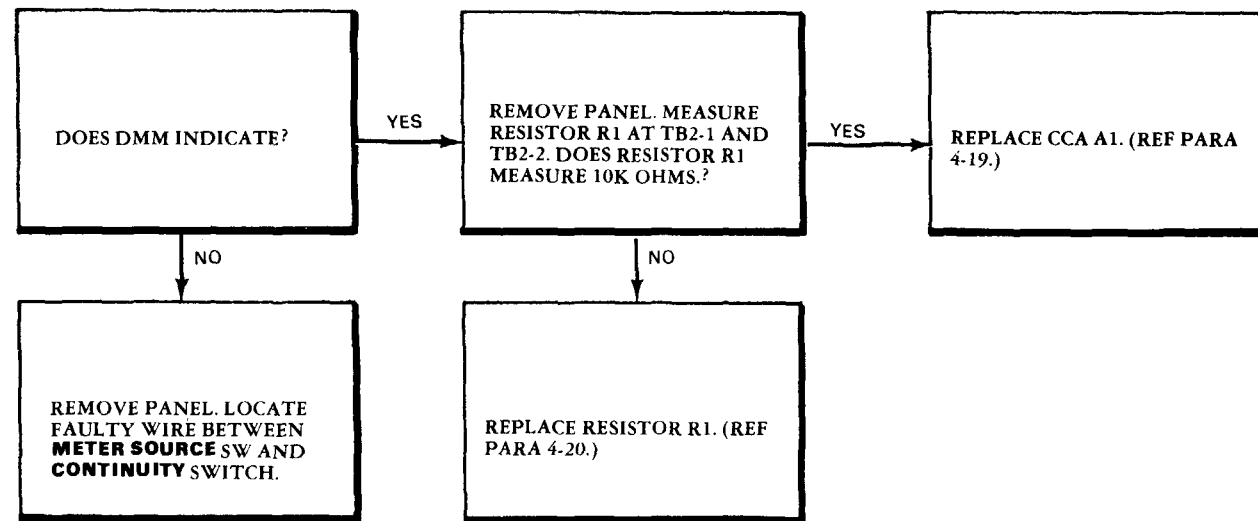

d. Indicators will not come on when SELF TEST switch is set to LAMPS.

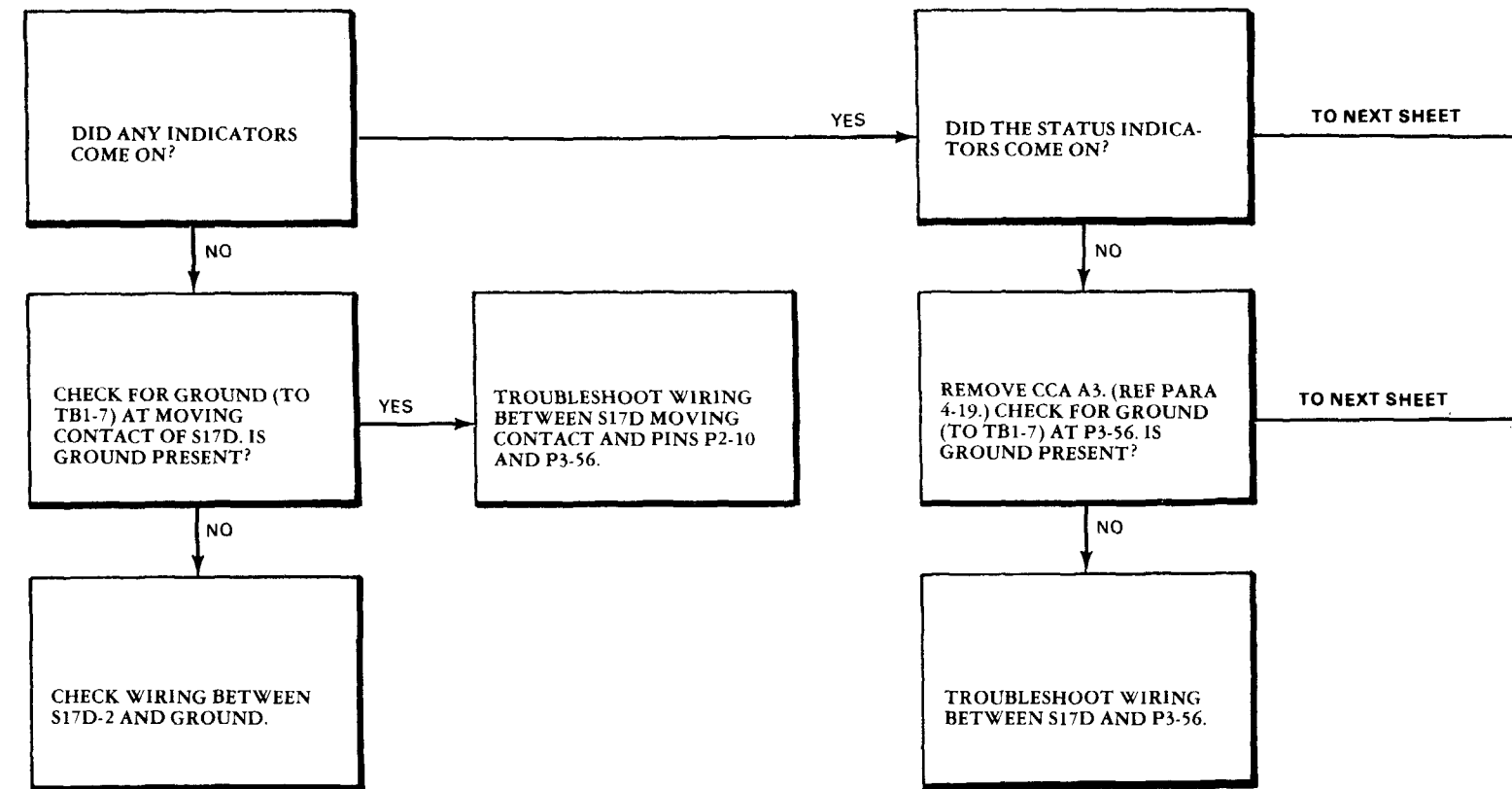

e. Indicators will not dim when DISPLAY BRIGHT/DIM switch is set to DIM.

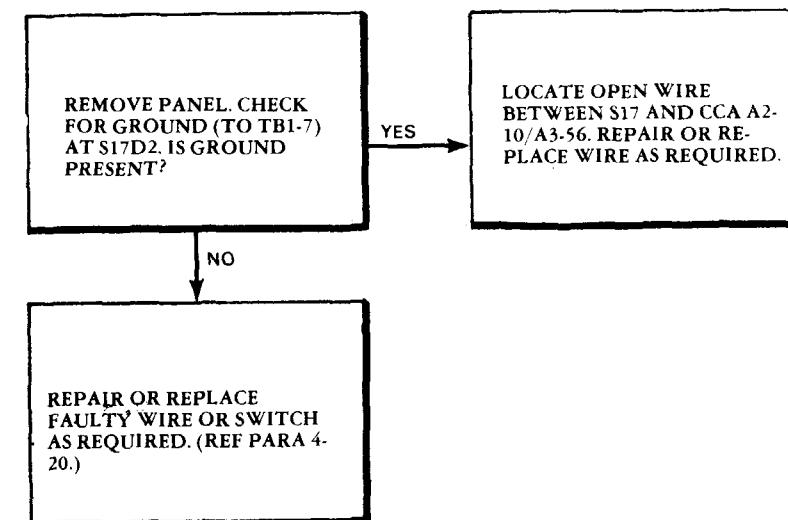

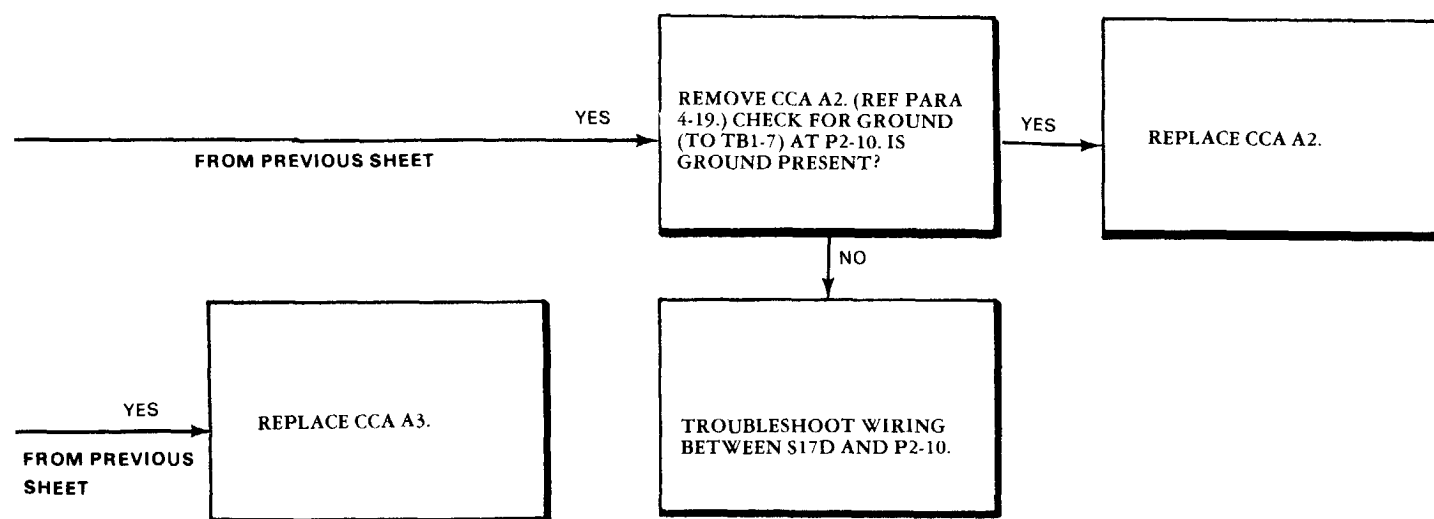

f. Multimeter digital display does not read +8.8.8.8. when SELF TEST switch is set to DISPLAY.

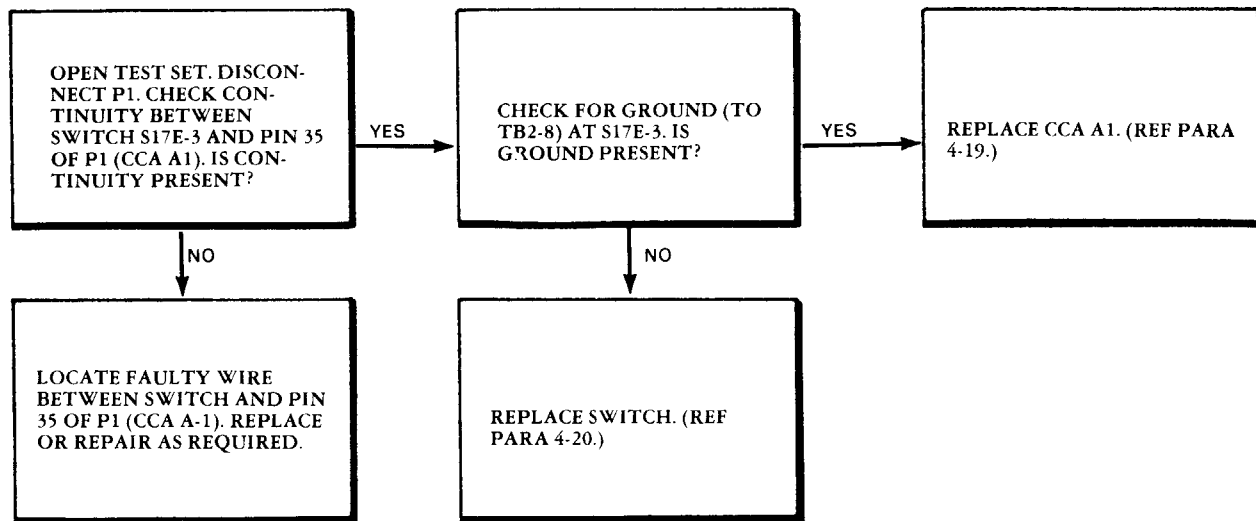

b. -DMM +15Vdc power supply out of tolerance during self test.

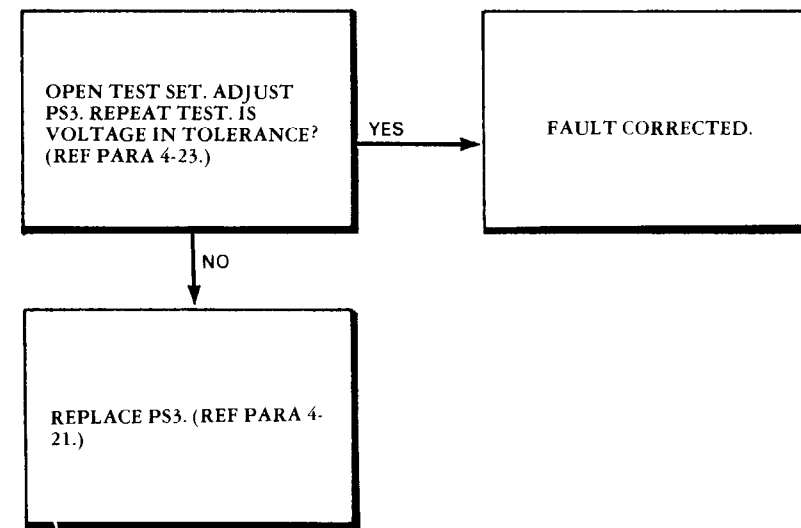

g. DMM +5 Vdc power supply out of tolerance during voltage source test.

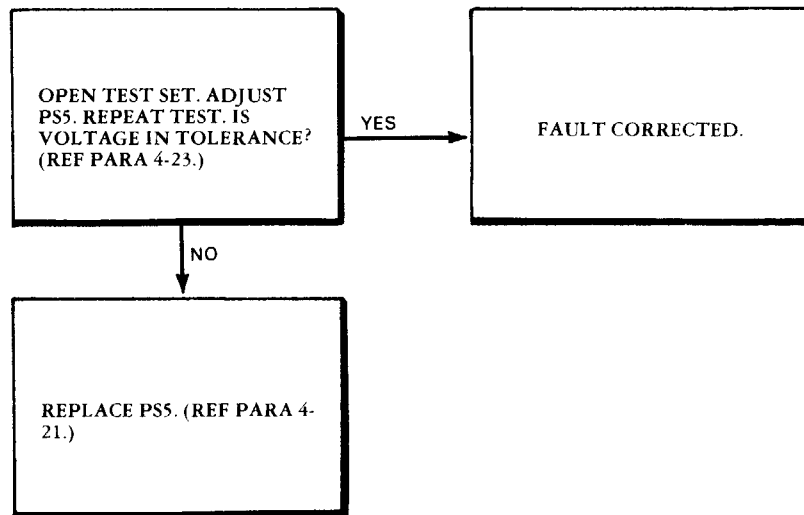

i. DMM -15Vdc power supply out of tolerance during self test.

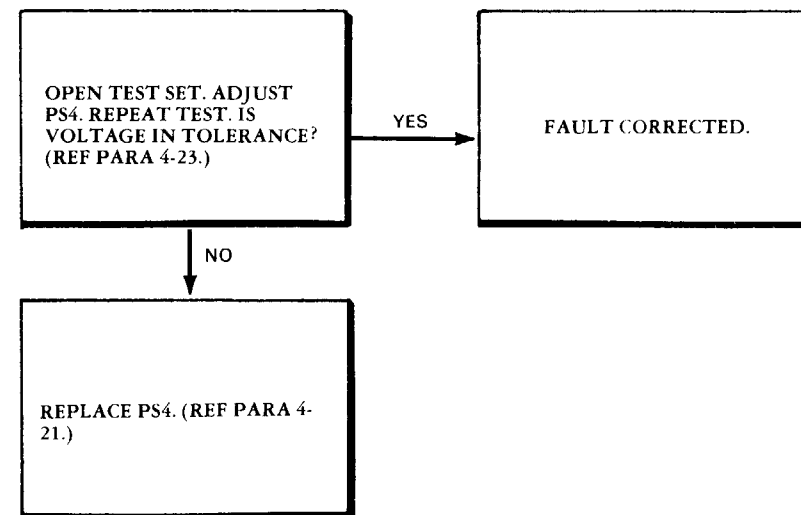

j. ± 3.6 Vac voltage out of tolerance during voltage source test.

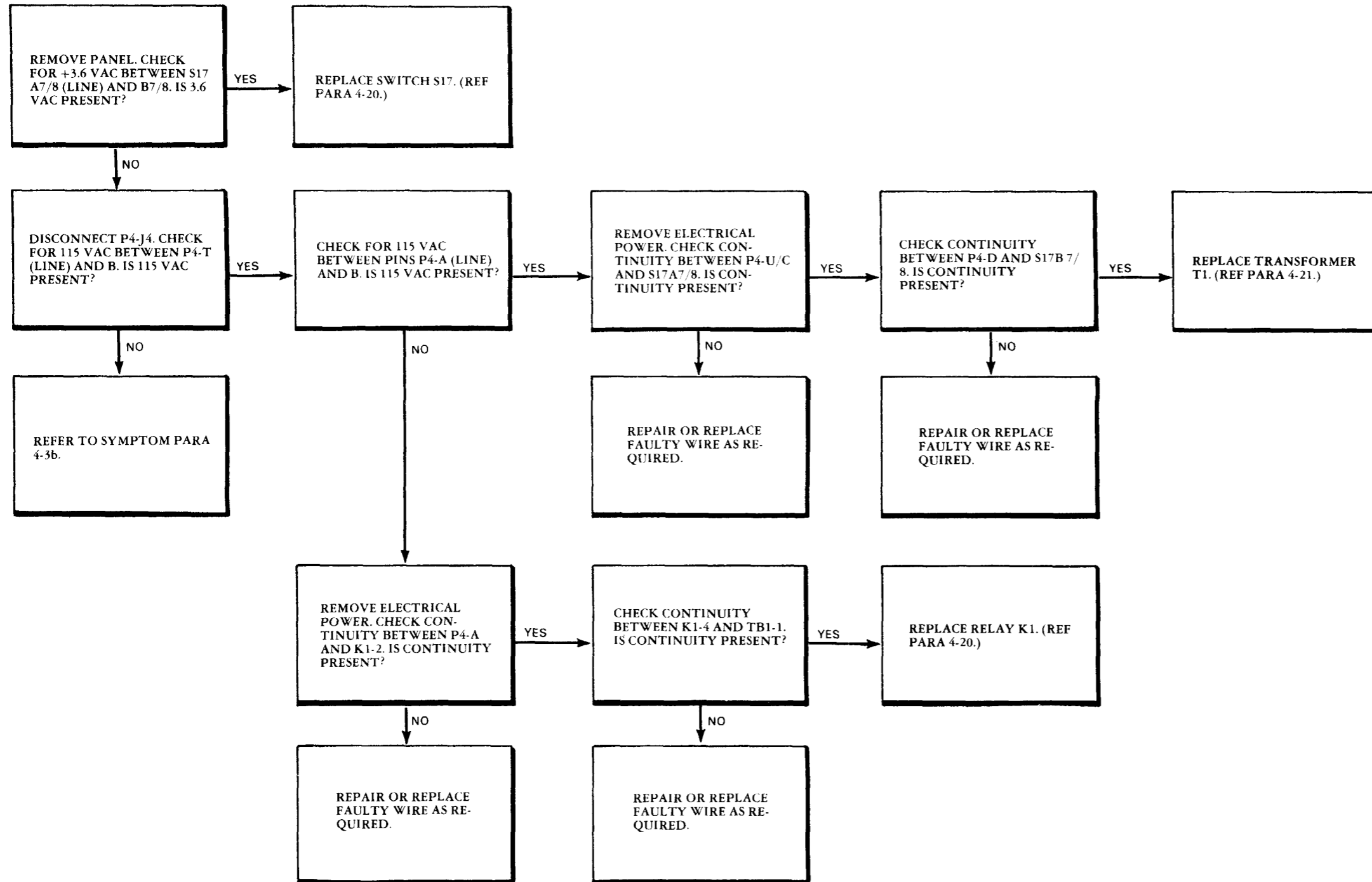

k. 13 Vac voltage out of tolerance during voltage source test.

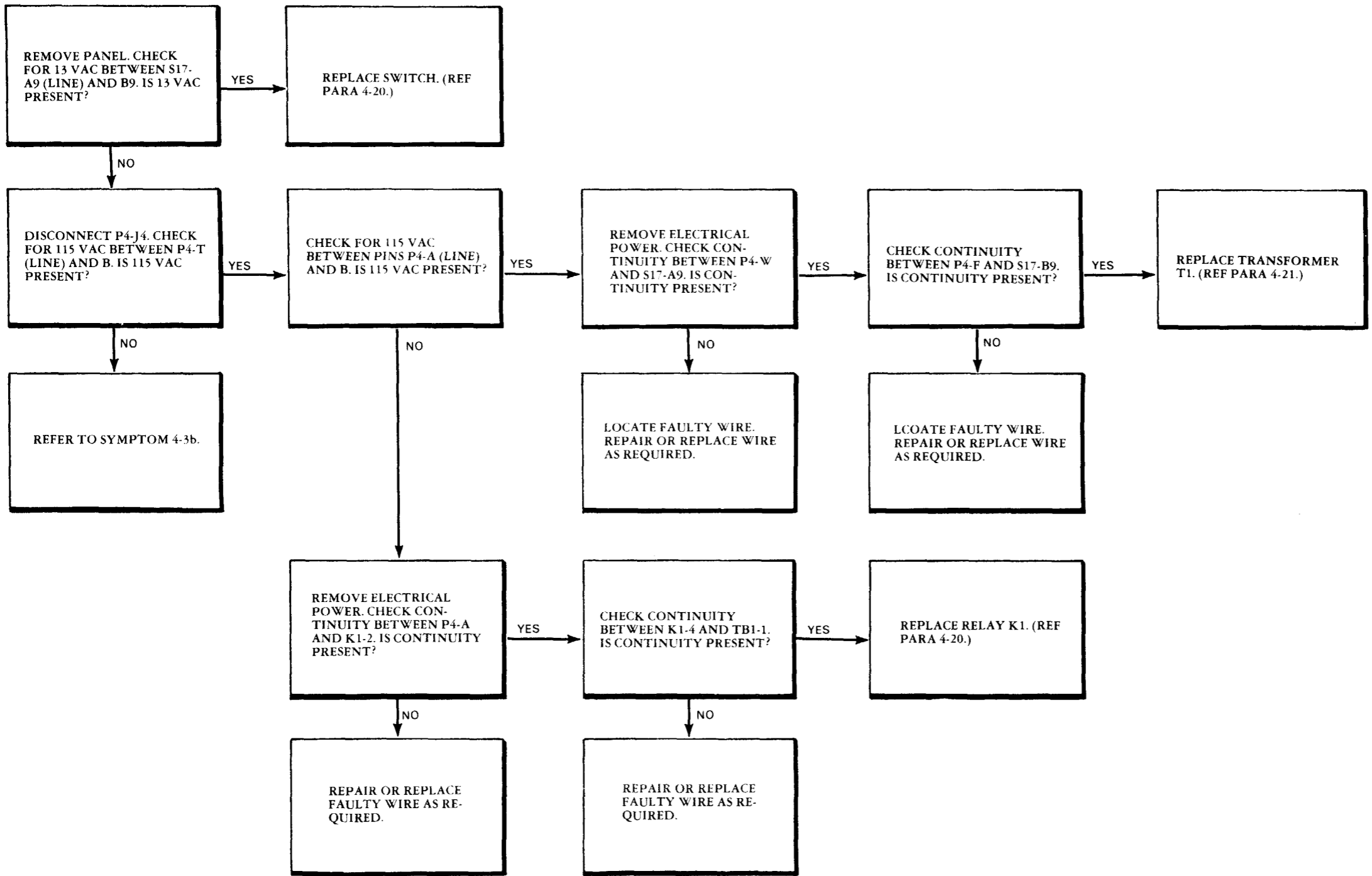

1. 26 Vac voltage out of tolerance during voltage source test.

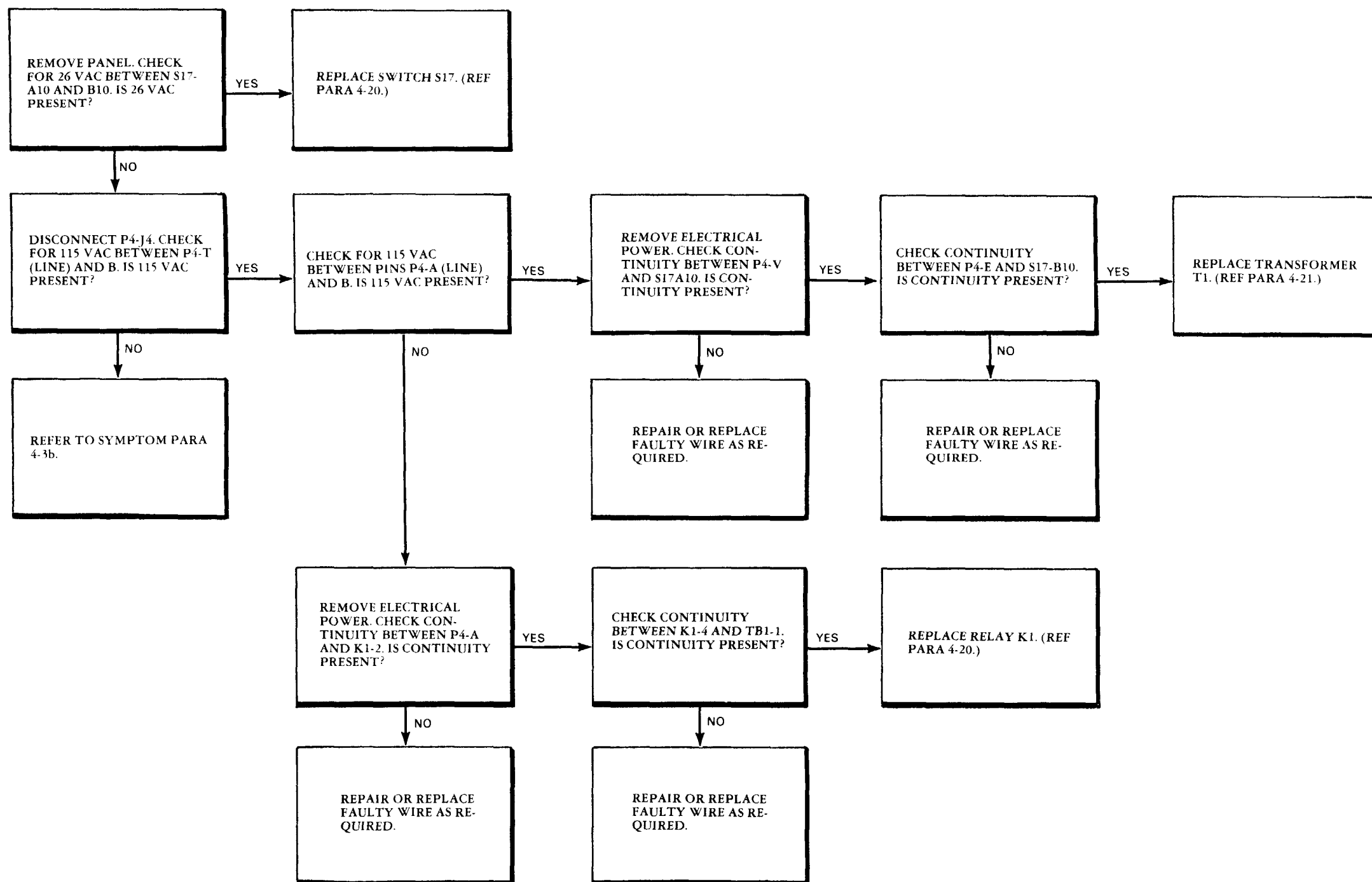

m. -7 Vdc out of tolerance during voltage source test.

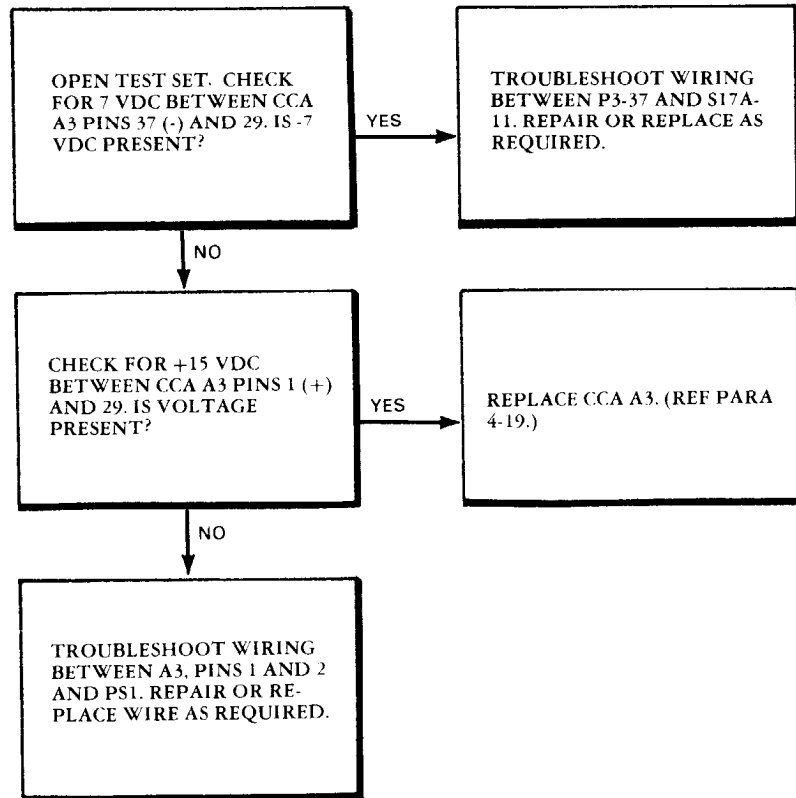

n. +7 Vdc source out of tolerance during voltage source test.

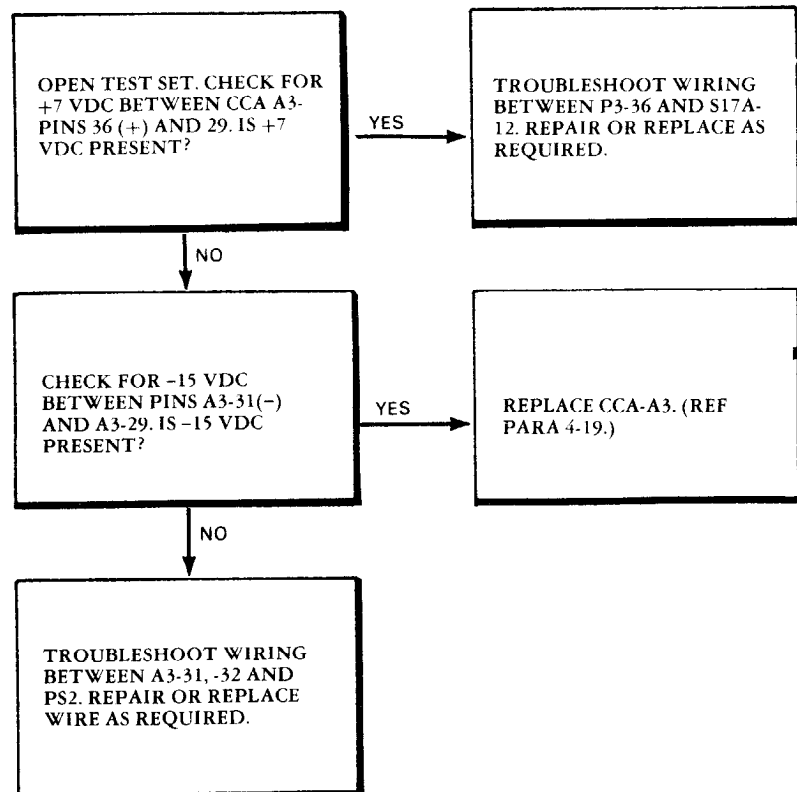

o. +12 Vdc source out of tolerance during voltage source test.

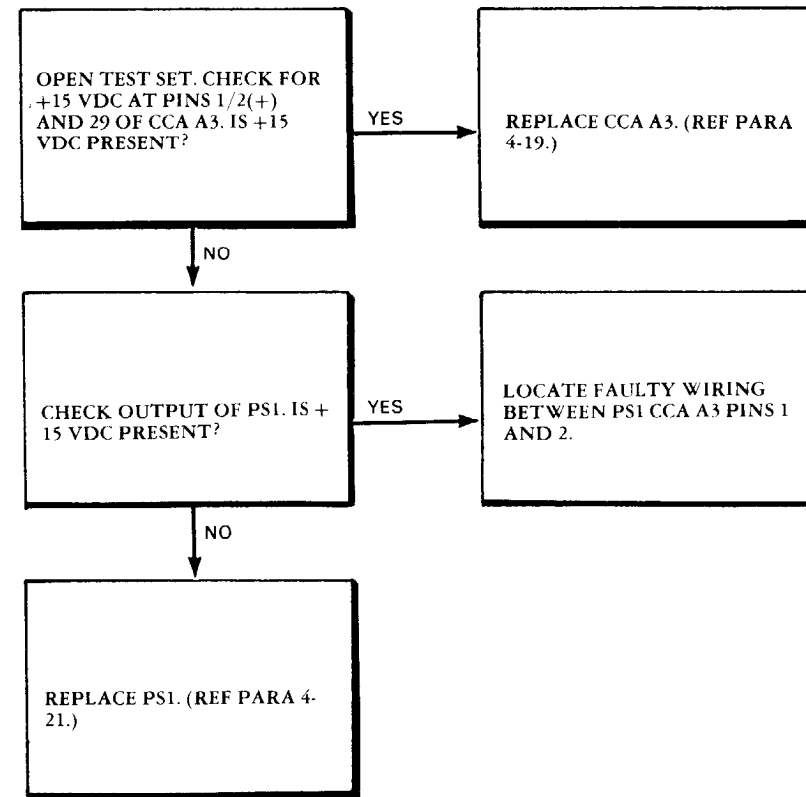

p. -15 Vdc power supply out of tolerance during voltage source test

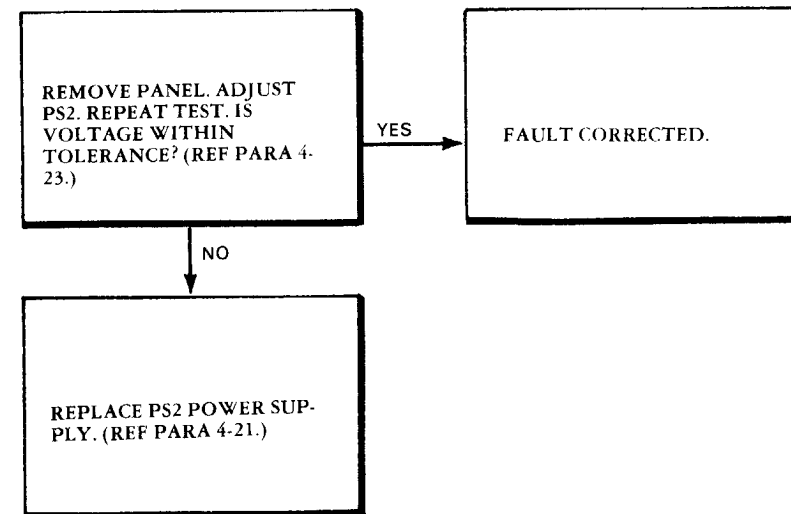

q. +15 Vdc power supply out of tolerance during self test.

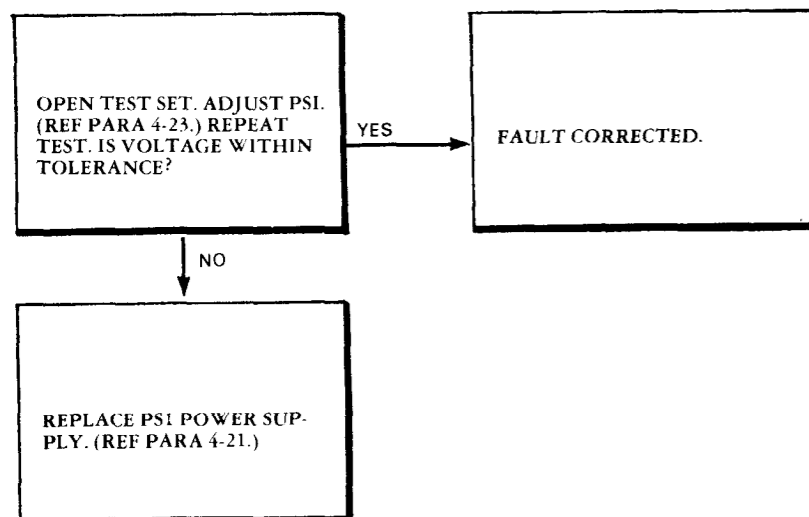

a. DMM MSD inaccurate with increasing/decreasing values of applied test voltages.

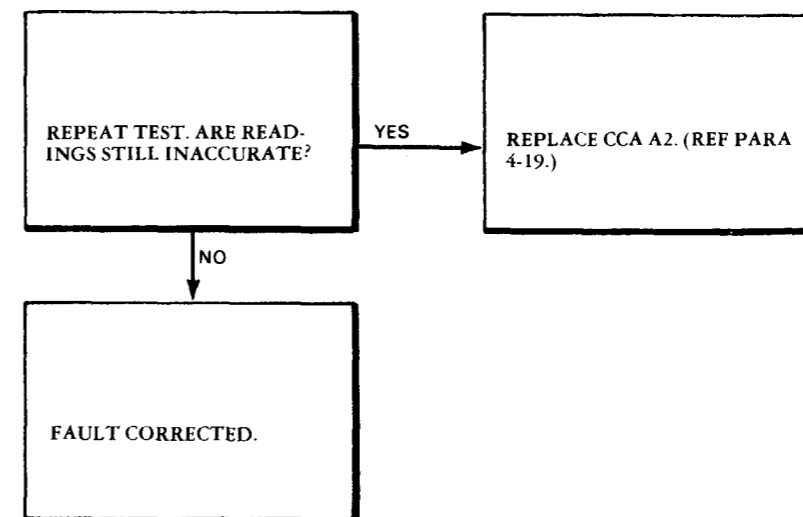

r. +28 Vdc power out of tolerance during voltage source test.

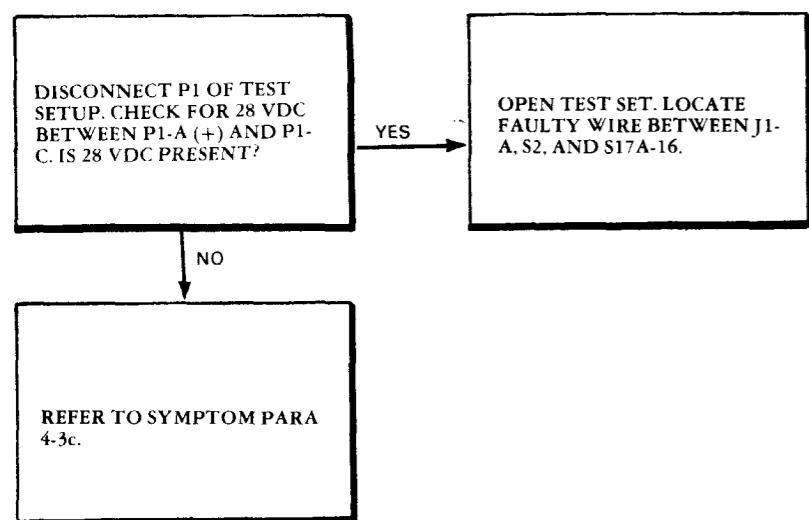

4-5. Multimeter Circuit Troubleshooting. Isolate fault to receptacle J3, FEEDBACK MONITOR switch S11, METER SOURCE switch S18, connector P2 at CCA A2, P1 at CCA1, CCA1, CCA2, or wiring. Repair or replace as required. See fig. 1-9 and 1-10.

b. DMM does not indicate with resistance decade across J1-H and J1-J.

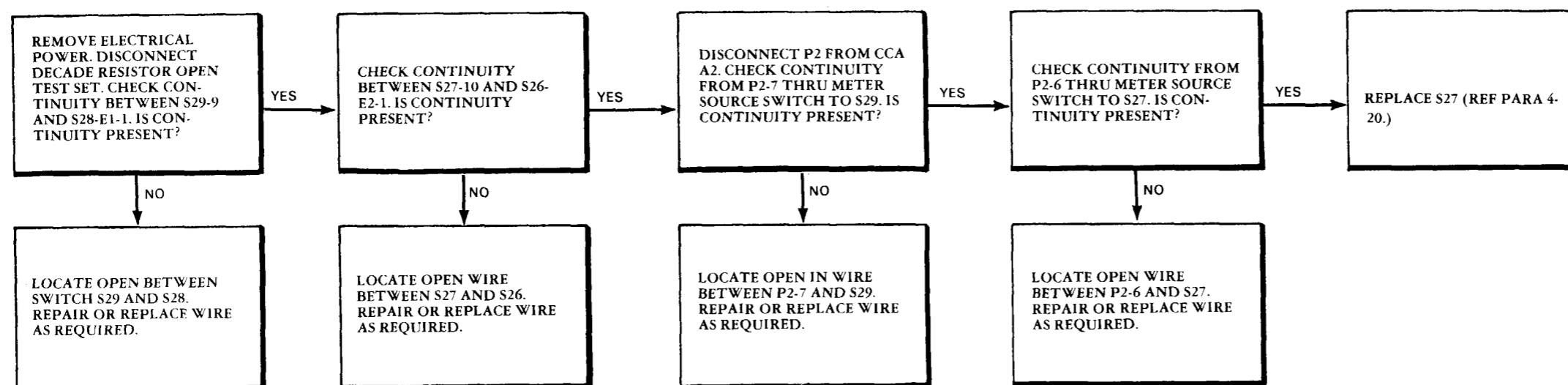

4-6. Discrete Signal Monitor Circuit Troubleshooting. Isolate fault to receptacle J1, J3, SIGNAL SEL switches 1 and 2 S23/S24, SEL1/SEL2 switch S22, connector P3 at CCA A3, or wiring. Repair or replace as required. See fig. 1-3 and 1-5.

4-7. ILCA Drive Circuit Troubleshooting. Isolate fault to receptacle J1, J3, switches S14, S15, S19, S20, S21, connector P3 at CCA A3 or wiring. Repair or replace as required. (See fig. 1-5.)

4-8. Gyro Test Troubleshooting. Isolate fault to receptacle J3, GYRO TEST switches S12, S13 or METER SOURCE switch S18. Repair or replace as required. (See fig. 1-11.)

NOTE: DMM malfunctions are covered in para 4-5.

4-9. CPT MONITOR Circuit Troubleshooting. Isolate fault to receptacle J1, CPT MONITOR switch S16, METER SOURCE switch S18, or wiring. Repair or replace as required. See fig. 1-11.

4-10. ACTUATOR DRIVE Circuit Troubleshooting. Isolate fault to receptacle J1, J3 ACTUATOR DRIVE switches S3-S7, S11, or wiring. Repair or replace as required. See fig. 1-11.

NOTE: Voltage source malfunctions are covered in para 4-4g thru 4-4r.

4-11. AFCS ANN Circuit Troubleshooting. Isolate fault to J3, switch S10, or wiring. Repair or replace as required. See fig. 1-11.

4-12. HDG SEL ENGAGE Circuit Troubleshooting. Isolate fault to J1, switch S30, or wiring. Repair or replace as required. See fig. 1-11.

4-13. DASH PRE-ENGAGE Circuit Troubleshooting. Isolate fault to J3, switch S31, or wiring. Repair or replace as required. See fig. 1-11.

NOTES:

- 1 - ALL LEADWIRE NO. 22 AWG MIL-W-168784 UNLESS OTHERWISE SPECIFIED
- △ - NO. 20 AWG MIL-W-168784
- 3 - ROTARY SW WAFER A IS NEAR PANEL
- 4 - NUMBER NEXT TO THE BASE LINE (HEAVY LINE) IDENTIFIES THE STATION NUMBER TO WHICH THE WIRE RUNS. NUMBER NEXT TO TERMINAL IS NUMBER MARKED ON WIRE AT EACH TERMINATION
- 5 - WIRES TO EDGE OF ROTARY SWITCH WAFERS CONNECT TO MOVING CONTACT OF SWITCH

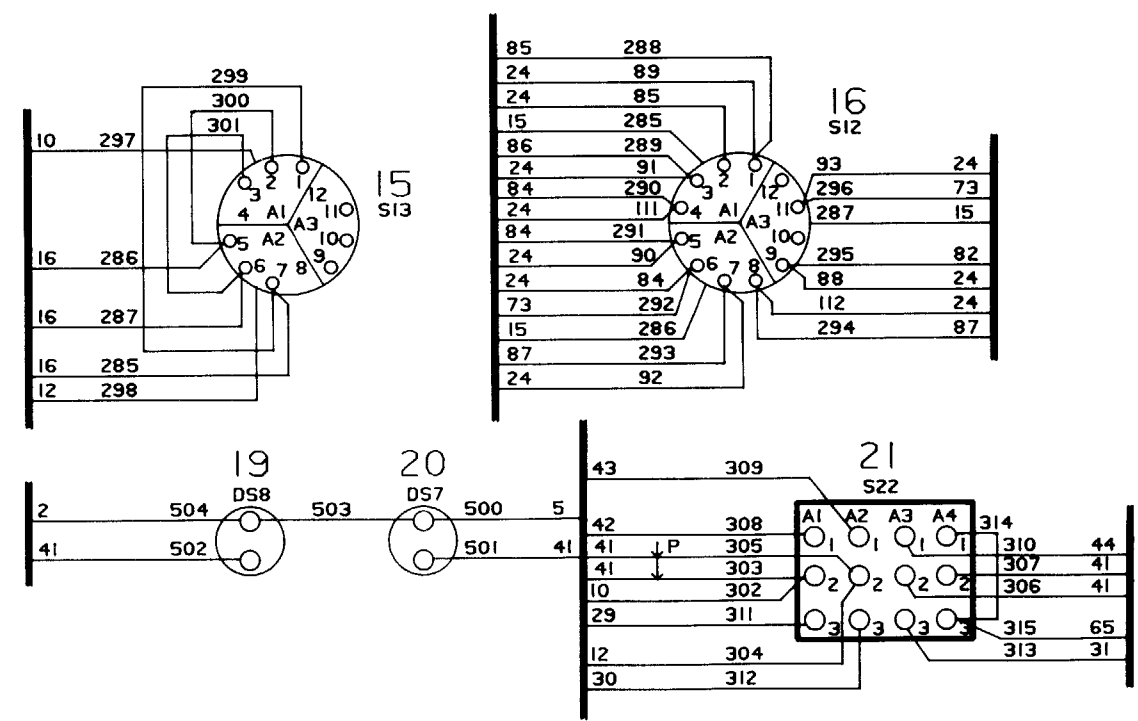
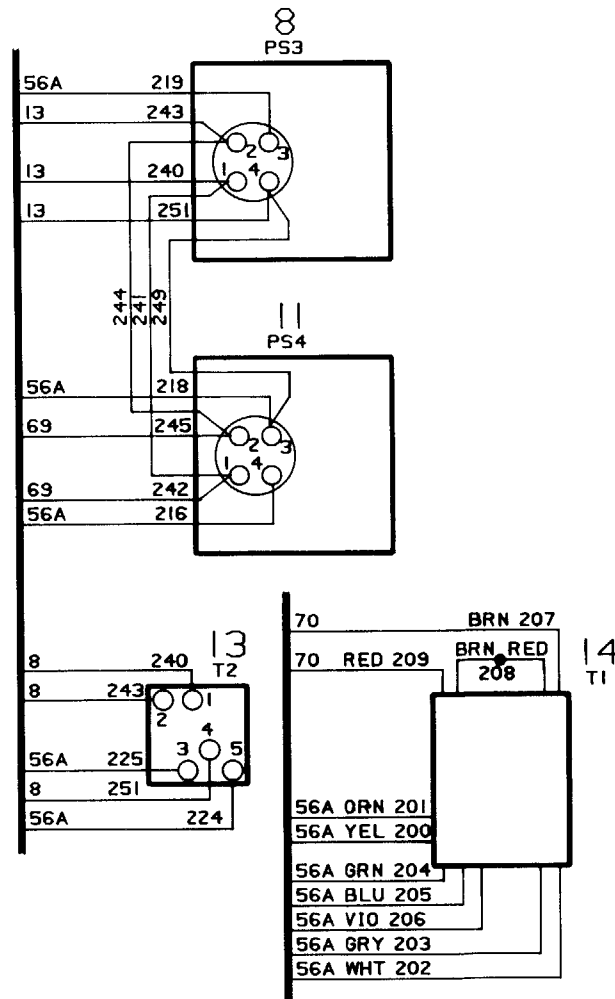
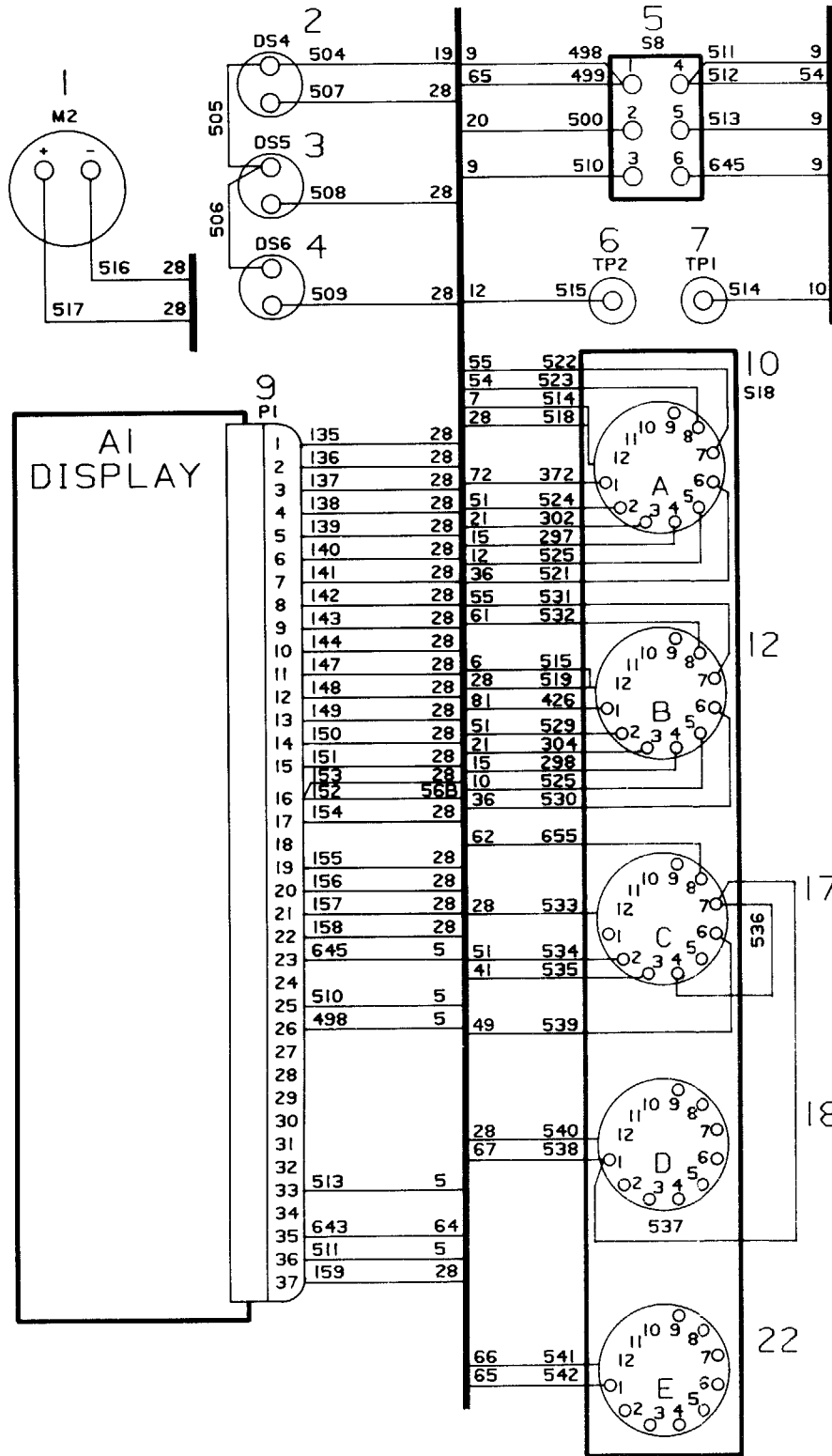

REAR VIEW OF FRONT PANEL

23
J1

59	11	A
57	12	B
60	13	C
58	14	D
75	15	E
84	16	F
85	17	G
87	18	H
86	19	J
74	20	K
73	21	L
78	22	M
77	23	N
68	24	P
61	25	R
39	26	S
39	27	T
90	29	V
86	30	W
87	31	X
68	32	Y
61	33	Z
29	34	a
53	35	b
53	36	c
82	39	f
84	40	g
84	41	h
87	42	i
86	43	j
74	44	k
73	45	n
82	50	e
83	51	t
84	53	v
29	54	w
86	56	y
86	57	z
74	58	A
73	59	B
77	63	F
78	64	G
82	65	H
82	66	I
85	67	J
84	68	K
86	69	L
86	70	M
74	71	N
		P

24
J3

73	72	A
12	73	B
77	74	C
32	75	D
32	76	E
57	77	F
29	78	G
34	79	H
35	80	J
36	81	K
36	82	L
74	83	M
6	84	N
16	85	P
42	86	R
32	87	S
16	88	T
16	89	U
16	90	V
16	91	W
16	92	X
16	93	Y
89	94	Z
42	95	a
29	96	b
77	97	c
29	98	d
82	99	e
85	100	f
84	101	g
29	102	h
29	103	i
29	104	j
29	105	k
82	108	p
83	109	q
85	110	r
16	111	s
16	112	t
87	113	u
73	114	v
74	115	w
77	116	x
77	117	y
42	118	z
43	119	AA
84	120	BB
84	121	
87	123	
42	124	::
42	125	
77	126	GG
48	127	JJ
82	128	KK
42	129	LL
84	130	MN
85	131	NN
87	132	PP

J1
PIN ARRANGEMENT

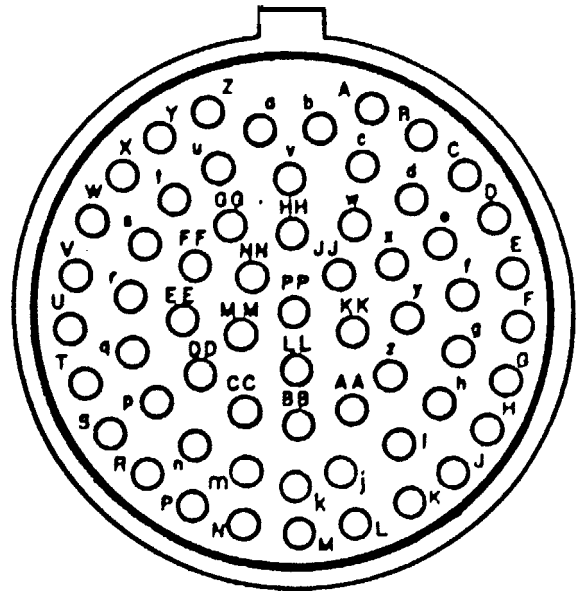

FRONT FACE VIEW

J3
PIN ARRANGEMENT

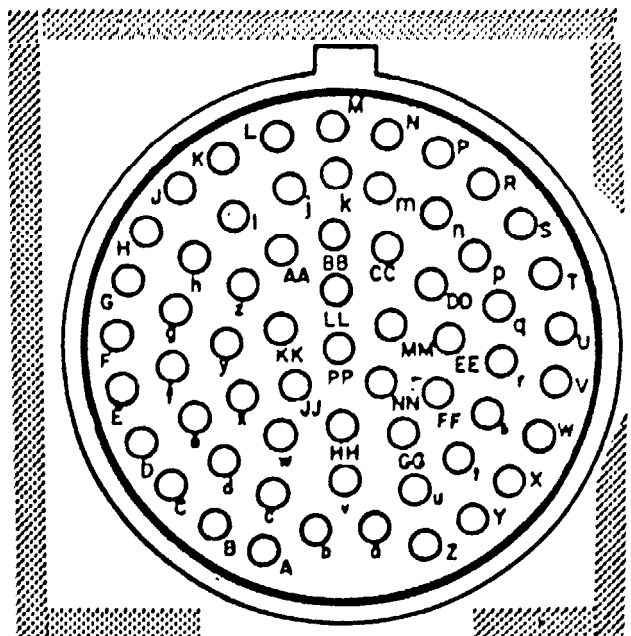

FRONT FACE VIEW

47D-TMDE-ALTS-38

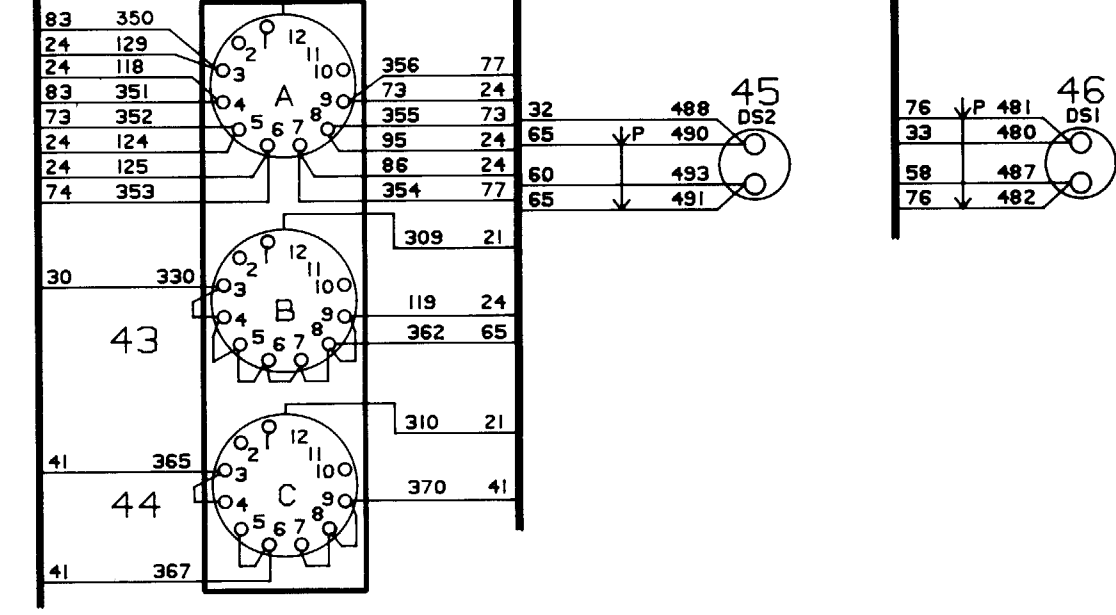
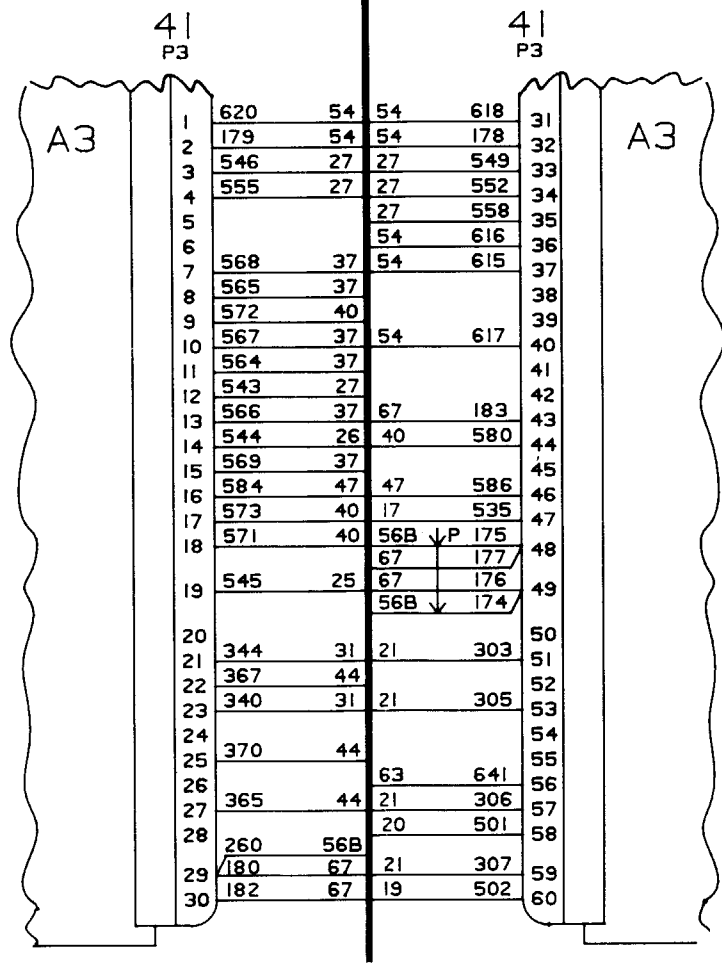
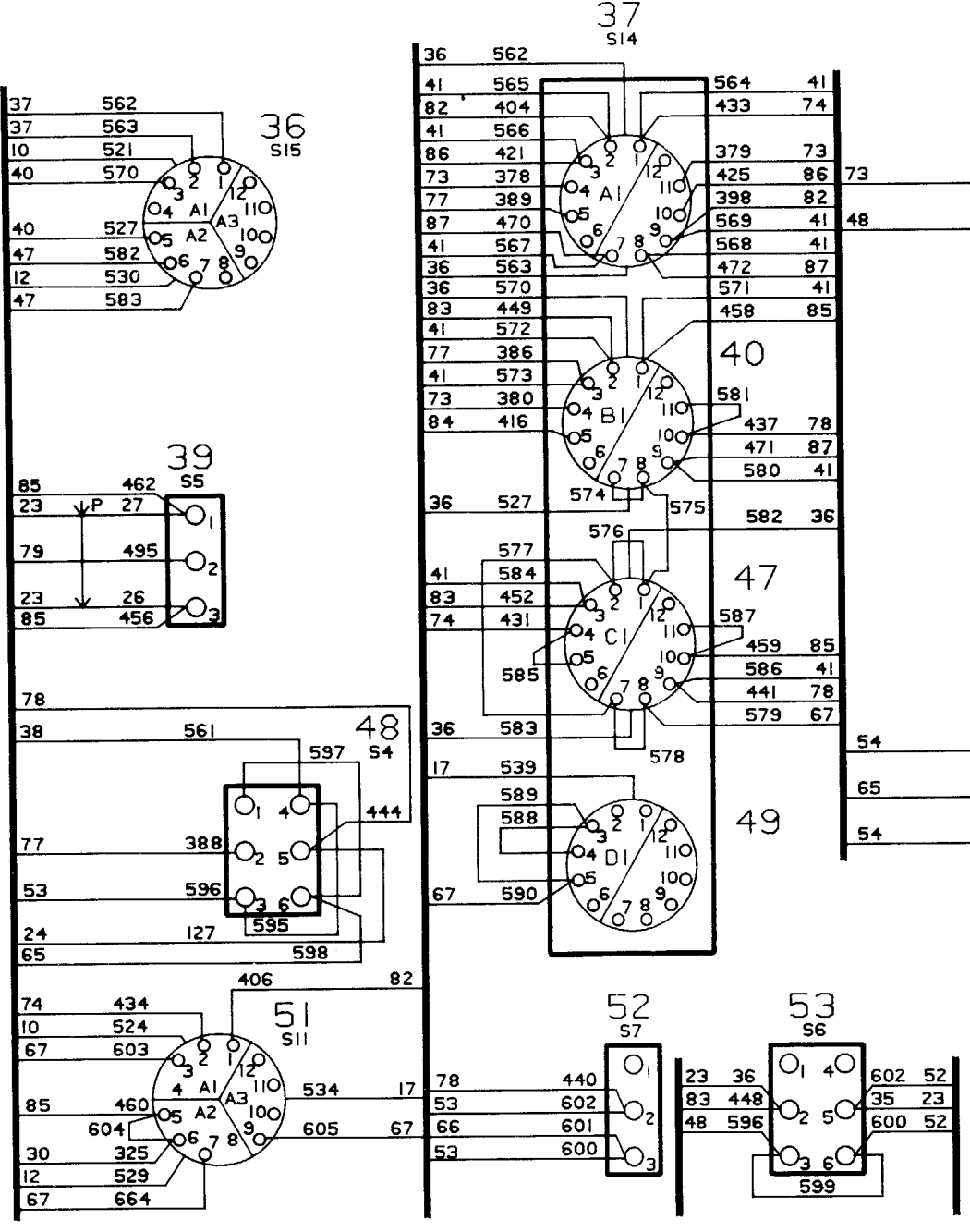
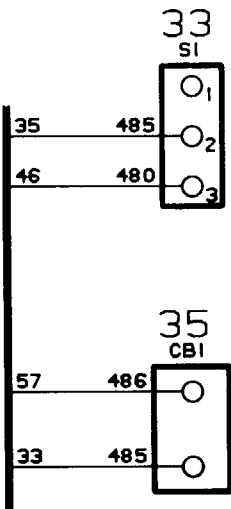
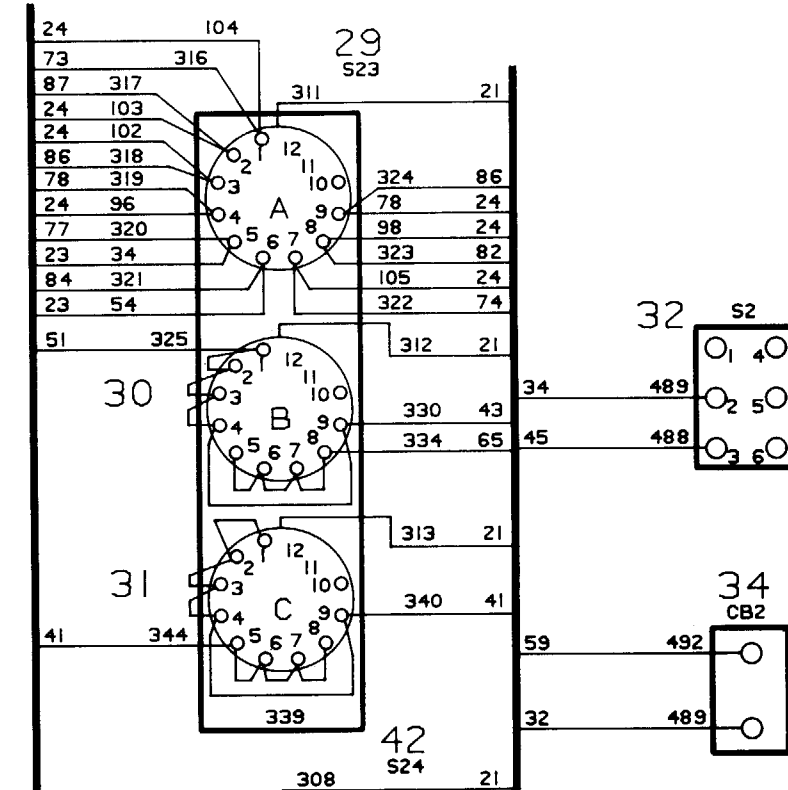
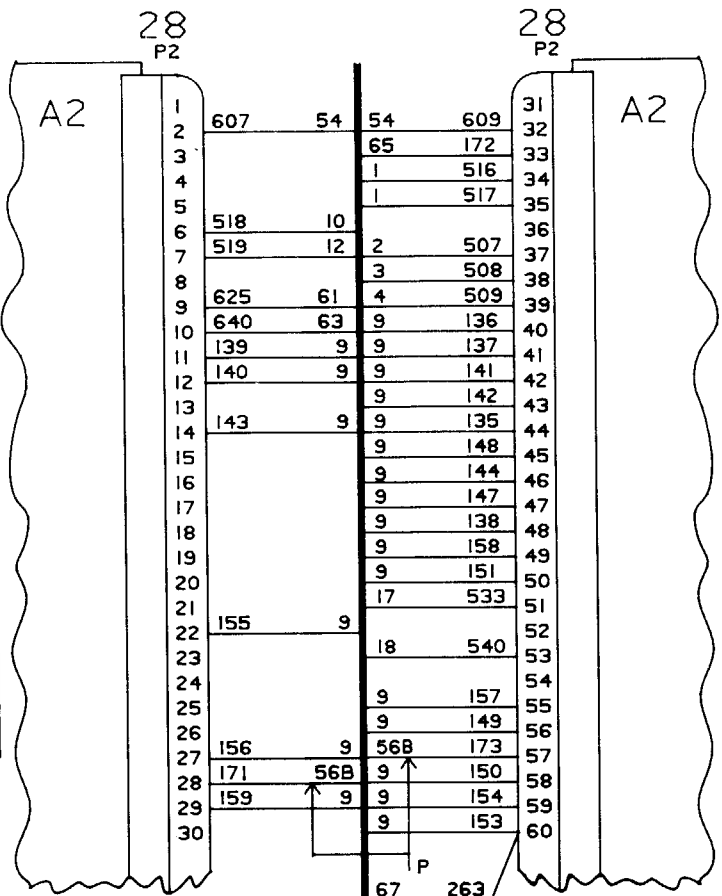
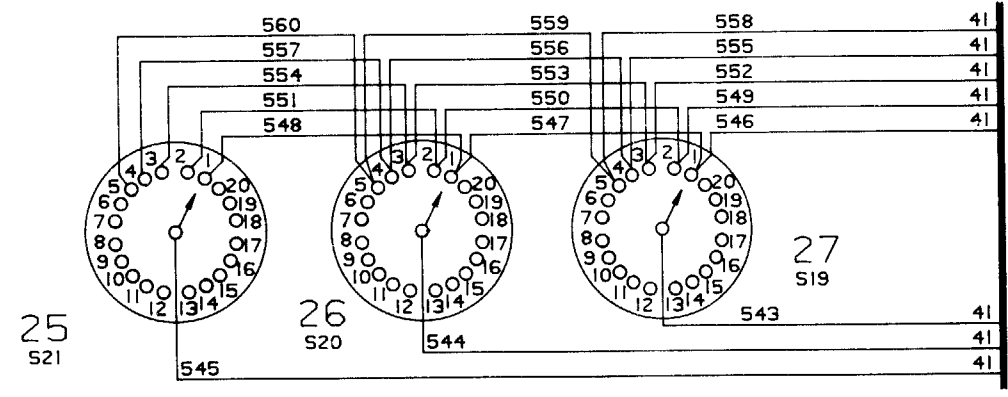

FO-22. Wiring Diagram (Sheet 3 of 5)

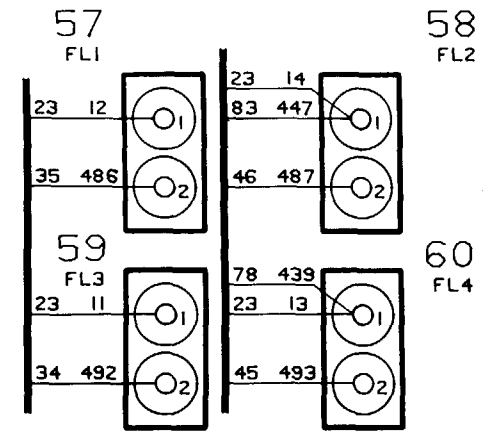
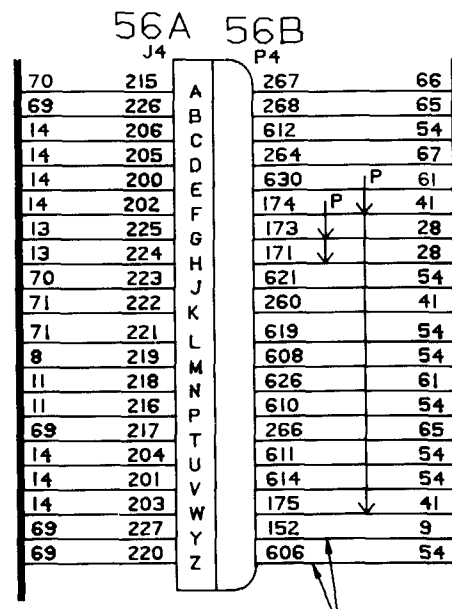
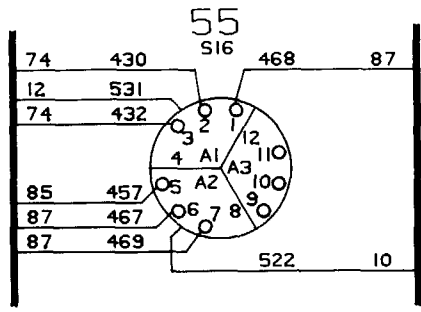
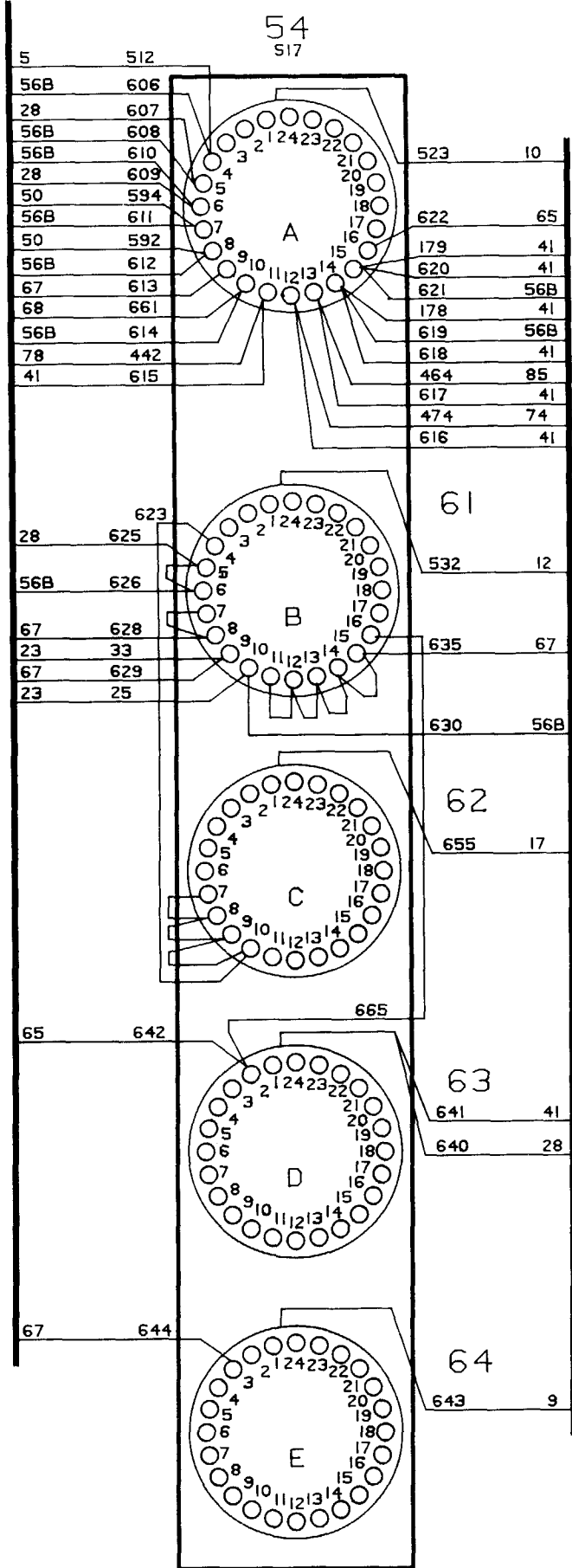

J4 PIN ARRANGEMENT

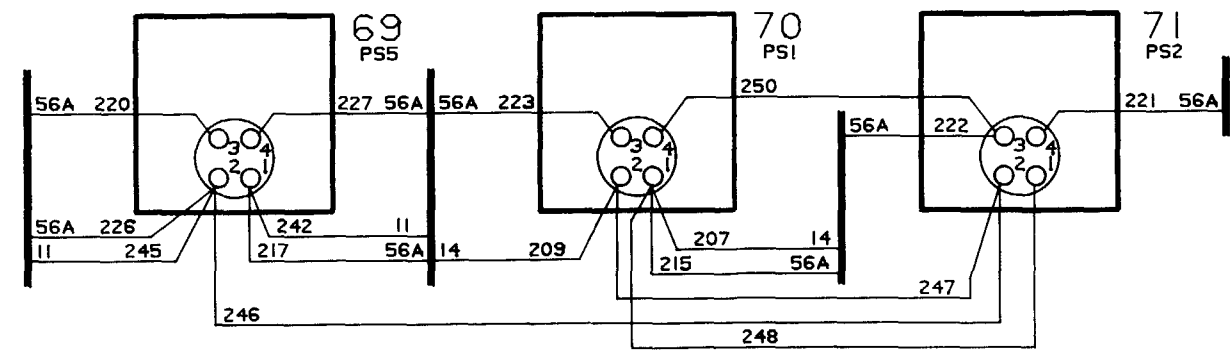
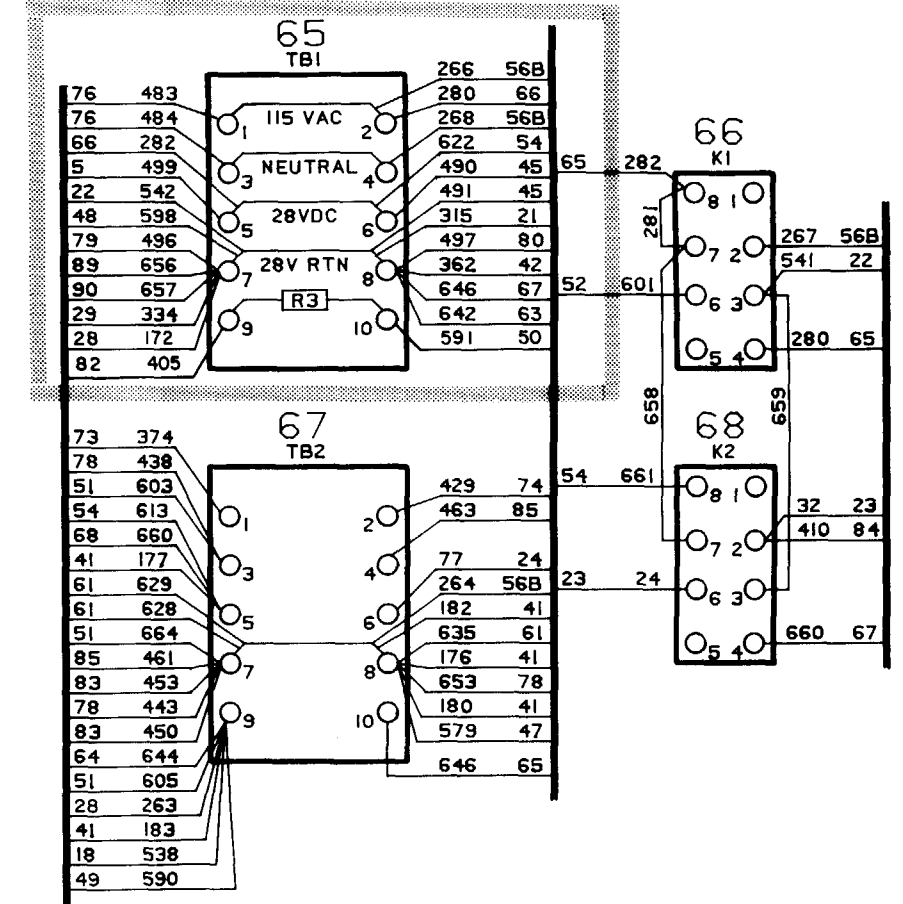
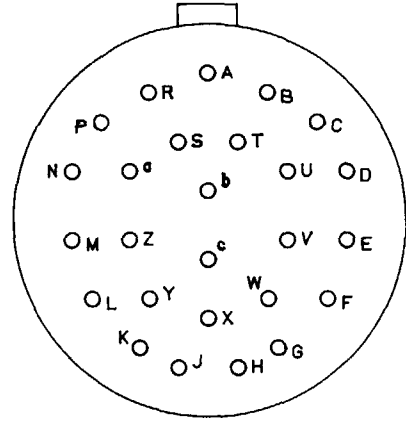

FO-22. Wiring Diagram (Sheet 4 of 5)

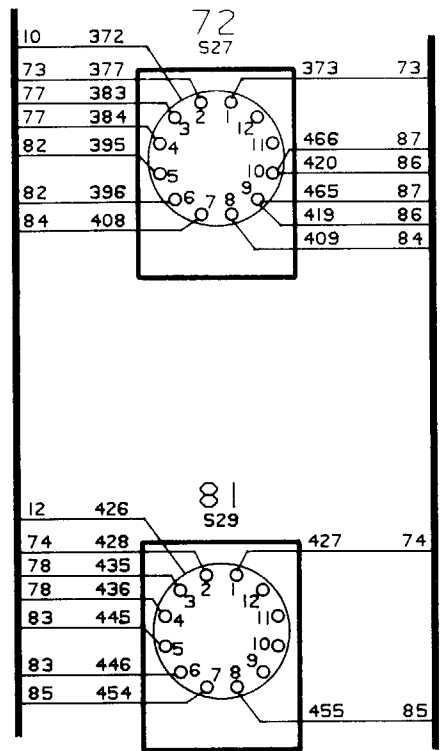

77

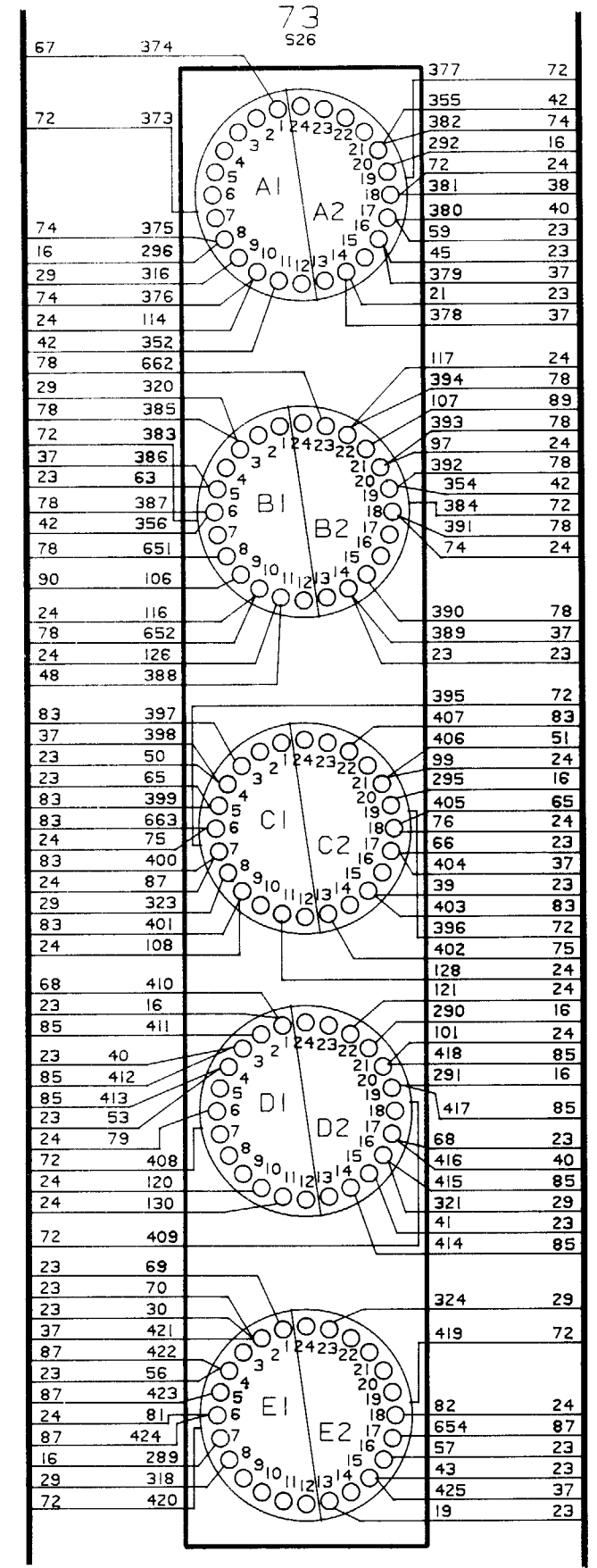

78

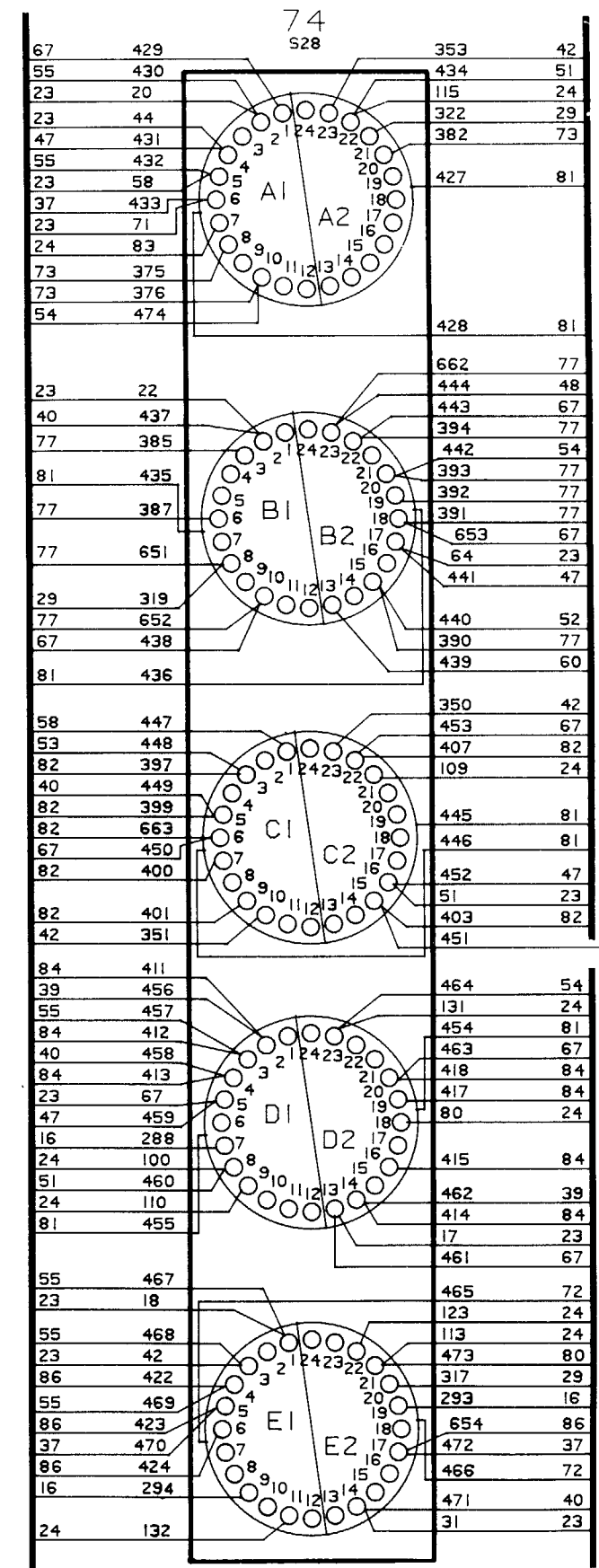

85

87

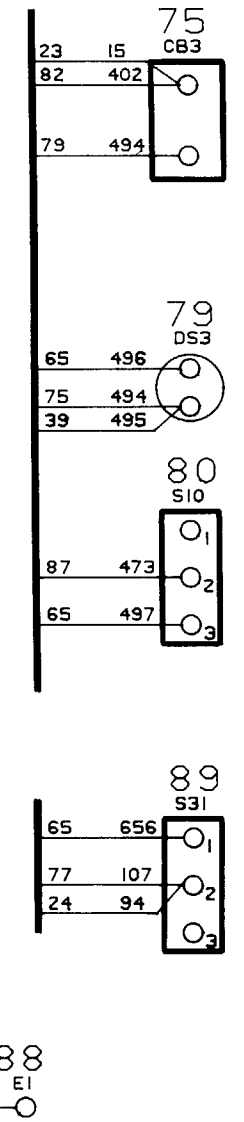

FO-22. Wiring Diagram (Sheet 5 of 5)

By Order of the Secretary of the Army:

Official:

JOHN A. WICKHAM, JR.
General, United States Army
Chief of Staff

ROBERT M. JOYCE
Major General, United States Army
The Adjutant General

DISTRIBUTION:

To be distributed in accordance with DA Form 12-31, Operator Maintenance requirements for CH-47B/C & D.



THEN... JOT DOWN THE DOPE ABOUT IT ON THIS FORM. CAREFULLY TEAR IT OUT. FOLD IT AND DROP IT IN THE MAIL!

SOMETHING WRONG WITH THIS PUBLICATION?

FROM (PRINT YOUR UNIT'S COMPLETE ADDRESS)
 CDR, 1st Br, 65th ADA
 ATTN: SP4 J. Brown
 Key West, FL 33040

DATE SENT
 10 Jun 79

PUBLICATION NUMBER
 TM 9-1430-550-34-1

PUBLICATION DATE
 7 Sep 72 .

PUBLICATION TITLE Unit of Radar Set
 AN/MPQ-50 Tested at the HFC

BE EXACT PIN-POINT WHERE IT IS

PAGE NO	PARA-GRAPH	FIGURE NO	TABLE NO
9-19		9-5	
21-2	step 1C	21-2	

SAMPLE

IN THIS SPACE TELL WHAT IS WRONG AND WHAT SHOULD BE DONE ABOUT IT:

"B" Ready Relay K11 is shown with two #9 contacts. That contact which is wired to pin 8 of relay K16 should be changed to contact #10.

Reads: Multimeter B indicates 600 K ohms to 9000 K ohms.

Change to read: Multimeter B indicates 600 K ohms minimum.

Reason: Circuit being checked could measure infinity. Multimeter can read above 9000 K ohms and still be correct.

PRINTED NAME GRADE OR TITLE AND TELEPHONE NUMBER

SP4 J.T. Brown, Jr.

SIGN HERE

SP4 James Brown, Jr.

DA FORM 2 JUL 79 2028-2

REPLACES DA FORM 2028-2 1 APR 78 WHICH WILL BE USED UNTIL EXHAUSTED
 AMVAV M Overprint 3, 1 Mar 91

P.S.--IF YOUR OUTFIT WANTS TO KNOW ABOUT YOUR RECOMMENDATION MAKE A CARBON COPY OF THIS AND GIVE IT TO YOUR HEADQUARTERS

TEAR ALONG PERFORATED LINE



THEN... JOT DOWN THE DOPE ABOUT IT ON THIS FORM. CAREFULLY TEAR IT OUT. FOLD IT AND DROP IT IN THE MAIL!

SOMETHING WRONG WITH THIS PUBLICATION?

FROM: (PRINT YOUR UNIT'S COMPLETE ADDRESS)

DATE SENT

PUBLICATION NUMBER
TM 55-4920-429-13

PUBLICATION DATE
16 Nov 1983

PUBLICATION TITLE
Test Set, Line, Advanced Flight Control System

BE EXACT. PIN-POINT WHERE IT IS

PAGE NO

PARA-GRAPH

FIGURE NO

TABLE NO

IN THIS SPACE TELL WHAT IS WRONG AND WHAT SHOULD BE DONE ABOUT IT:

PRINTED NAME GRADE OR TITLE AND TELEPHONE NUMBER

SIGN HERE

FILL IN YOUR
UNITS ADDRESS



FOLD BACK

DEPARTMENT OF THE ARMY

OFFICIAL BUSINESS

COMMANDER
U.S. ARMY AVIATION AND TROOP COMMAND
ATTN: AMSAT-I-MP
4300 GOODFELLOW BOULEVARD
ST. LOUIS, MO 63120-1798

TEAR ALONG PERFORATED LINE

The Metric System and Equivalents

Linear Measure

1 centimeter = 10 millimeters = .39 inch
 1 decimeter = 10 centimeters = 3.94 inches
 1 meter = 10 decimeters = 39.37 inches
 1 dekameter = 10 meters = 32.8 feet
 1 hectometer = 10 dekameters = 328.08 feet
 1 kilometer = 10 hectometers = 3,280.8 feet

Weights

1 centigram = 10 milligrams = .15 grain
 1 decigram = 10 centigrams = 1.54 grains
 1 gram = 10 decigrams = .035 ounce
 1 dekagram = 10 grams = .35 ounce
 1 hectogram = 10 dekagrams = 3.52 ounces
 1 kilogram = 10 hectograms = 2.2 pounds
 1 quintal = 100 kilograms = 220.46 pounds
 1 metric ton = 10 quintals = 1.1 short tons

Liquid Measure

1 centiliter = 10 milliliters = .34 fl. ounce
 1 deciliter = 10 centiliters = 3.38 fl. ounces
 1 liter = 10 deciliters = 33.81 fl. ounces
 1 dekaliter = 10 liters = 2.64 gallons
 1 hectoliter = 10 dekaliters = 26.42 gallons
 1 kiloliter = 10 hectoliters = 264.18 gallons

Square Measure

1 sq. centimeter = 100 sq. millimeters = .155 sq. inch
 1 sq. decimeter = 100 sq. centimeters = 15.5 sq. inches
 1 sq. meter (centare) = 100 sq. decimeters = 10.76 sq. feet
 1 sq. dekameter (are) = 100 sq. meters = 1,076.4 sq. feet
 1 sq. hectometer (hectare) = 100 sq. dekameters = 2.47 acres
 1 sq. kilometer = 100 sq. hectometers = .386 sq. mile

Cubic Measure

1 cu. centimeter = 1000 cu. millimeters = .06 cu. inch
 1 cu. decimeter = 1000 cu. centimeters = 61.02 cu. inches
 1 cu. meter = 1000 cu. decimeters = 35.31 cu. feet

Approximate Conversion Factors

To change	To	Multiply by	To change	To	Multiply by
inches	centimeters	2.540	ounce-inches	newton-meters	.007062
feet	meters	.305	centimeters	inches	.394
yards	meters	.914	meters	feet	3.280
miles	kilometers	1.609	meters	yards	1.094
square inches	square centimeters	6.451	kilometers	miles	.621
square feet	square meters	.093	square centimeters	square inches	.155
square yards	square meters	.836	square meters	square feet	10.764
square miles	square kilometers	2.590	square meters	square yards	1.196
acres	square hectometers	.405	square meters	square miles	.386
cubic feet	cubic meters	.028	square kilometers	square hectometers	2.471
cubic yards	cubic meters	.765	square hectometers	acres	35.315
fluid ounces	milliliters	29,573	cubic meters	cubic feet	35.315
pints	liters	.473	cubic meters	cubic yards	1.308
quarts	liters	.946	milliliters	fluid ounces	.034
gallons	liters	3.785	liters	pints	2.113
ounces	grams	28.349	liters	quarts	1.057
pounds	kilograms	.454	liters	gallons	.264
short tons	metric tons	.907	grams	ounces	.035
pound-feet	newton-meters	1.356	kilograms	pounds	2.205
pound-inches	newton-meters	.11296	metric tons	short tons	1.102

Temperature (Exact)

°F Fahrenheit temperature 5/9 (after subtracting 32) Celsius temperature °C

